

ESE 2023 Prelims

Electrical Engineering

Paper-2 (Set-A)

Official Questions with
Detailed Solutions



ESE EE 2023 Prelims Paper-2 : Major Highlights

- **Overall Difficulty Level:** Easy to Moderate
- **Subject wise difficulty level:** Easy to Moderate
- **Theoretical & Numerical:** 65 Numerical 85 Theoretical
- **Assertion/Reason:** 6
- **Comparison from last year:** Same difficulty last as last year

ESE EE 2023 Prelims Paper-2 : Subject-wise Weightage Distribution

S. No.	Subjects	Total Questions	Difficulty Level
1.	Digital Electronics	1	Easy
2.	Analog Electronics	10	Easy
3.	Electric Circuits	9	Easy
4.	Signals & Systems	13	Easy
5.	Control Systems	13	Moderate
6.	Electromagnetic Fields	0	–
7.	Measurements	13	Moderate
8.	Material Science	10	Moderate
9.	Microprocessors	1	Moderate
10.	Basic Electronics Engineering	10	Moderate
11.	Communication Systems	8	Moderate
12.	Computer Fundamentals	11	Moderate
13.	Electrical Machines	14	Easy
14.	Power Electronics	12	Easy
15.	Power Systems	13	Moderate
16.	Engineering Mathematics	12	Moderate

ESE EE 2023 Prelims Paper-2 : Comparison with Last 3 Years' Data

S. No.	Subjects	2023	2022	2021	2020
1.	Digital Electronics	1	0	3	3
2.	Analog Electronics	10	11	14	12
3.	Electric Circuits	9	7	11	7
4.	Signals & Systems	13	12	8	11
5.	Control Systems	13	12	12	12
6.	Electromagnetic Fields	0	3	2	6
7.	Electrical & Electronics Measurements	13	12	12	12
8.	Material Science	10	14	14	10
9.	Microprocessors	1	0	4	1
10.	Basic Electronics Engineering	10	4	5	7
11.	Communication Systems	8	13	8	9
12.	Computer Fundamentals	11	12	6	11
13.	Electrical Machines	14	14	17	16
14.	Power Electronics	11	11	8	10
15.	Power Systems	14	13	11	11
16.	Engineering Mathematics	12	12	15	12
Total		150	150	150	150

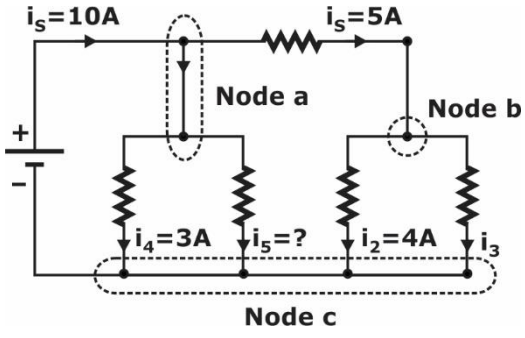

- A. 2A and 1A
- B. 1A and 2A
- C. 18 A and 9A
- D. 9 A and 18 A

Ans. B

Sol. Apply KCL at node b,

$$i_1 = i_2 + i_3$$

$$i_3 = i_1 - i_2$$

$$= 5 - 4 = 1A$$

Apply KCL at node a,

$$i_s = i_1 + i_4 + i_5$$

$$10 = 5 + 3 + i_5$$

$$I_5 = 2A$$

4. What is the current delivered by the 10V source in the circuit shown below?

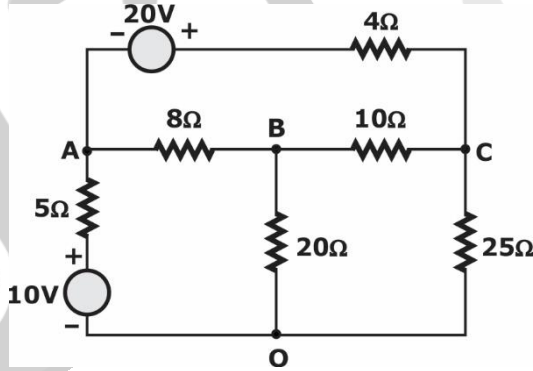

- A. 2.132 A
- B. 3.132 A
- C. 1.132 A
- D. 0.532 A

Ans. D

Sol.

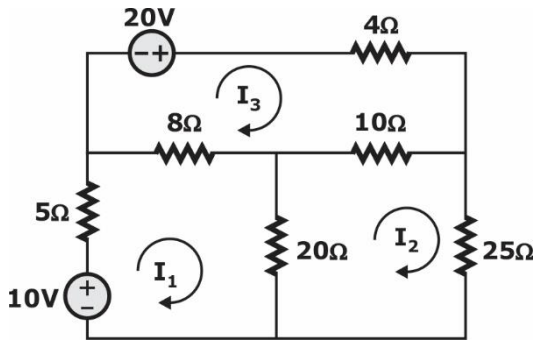

Apply KVL in loop (1);

$$5I_1 + 8(I_1 - I_3) + 20(I_1 - I_2) = 10$$

$$33I_1 - 20I_2 - 8I_3 = 10 \quad \dots(1)$$

Apply KVL in loop (2);

$$10(I_1 - I_3) + 25I_2 + 20(I_2 - I_1) = 0$$

$$-20I_1 + 55I_2 - 10I_3 = 0 \quad \dots(2)$$

Apply KVL in loop (3);

$$4I_3 + 10(I_3 - I_2) + 8(I_3 - I_1) = 0$$

$$-8I_1 - 10I_2 + 22I_3 = 0 \quad \dots(3)$$

Solving all equations
 $I_1 = 0.532; I_2 = 0.24; I_3 = 0.3$
 So, $I_1 = 0.532 \text{ A}$

5. The following circuit shown in the figure has a voltage source and a dependent current source. What is the Thevenin equivalent resistance at terminals a – b?

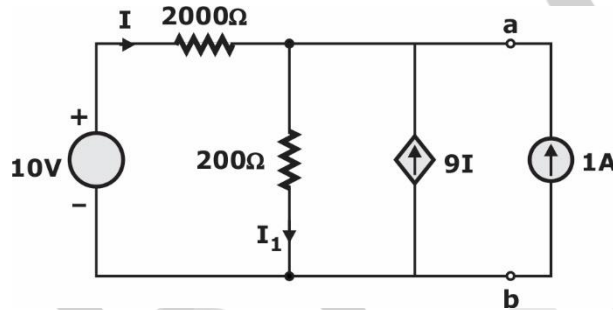

- A. 10 Ω
- B. 20 Ω
- C. 100 Ω
- D. 200 Ω

Ans. C

Sol.

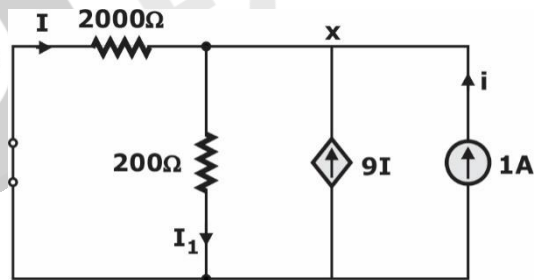

$$I_1 = \frac{1}{200}$$

$$I = -\frac{1}{2000}$$

By KCL at x

$$I = 9I + i = I_1$$

$$10I + i = I_1$$

$$-\frac{1}{200} + i = \frac{1}{200}$$

$$i = \frac{1}{100}$$

$$R_{Th} = \frac{1}{i}$$

$$= 100\Omega$$

6. An experimental circuit as shown in the figure below has the variable resistor R_L which is adjusted to the value of the load resistor as 10Ω . What is the maximum load power?

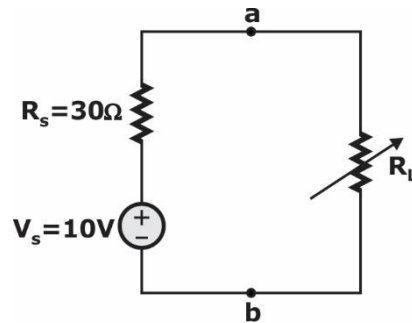

A. 981 mW

B. 816 mW

C. 733 mW

D. 625 mW

Ans. D

Sol.

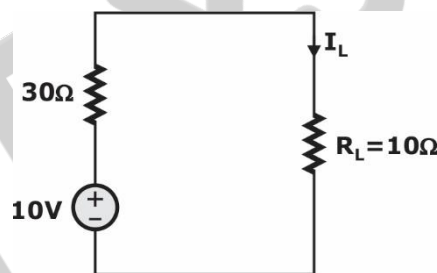

$$I_L = \frac{10}{30 + 10} = \frac{1}{4}$$

$$P_{max} = I_L^2 R_L$$

$$= \left(\frac{1}{4}\right)^2 \times 10$$

$$= 0.625 \text{ W}$$

$$= 625 \text{ mW}$$

7. In the circuit of the figure shown below, the source voltage is 100 V, the resistance is $10 \text{ k}\Omega$, and the capacitance is $0.005 \mu\text{F}$. In how much time can the capacitor voltage be discharged to 5 V after the switch is turned to position 3?

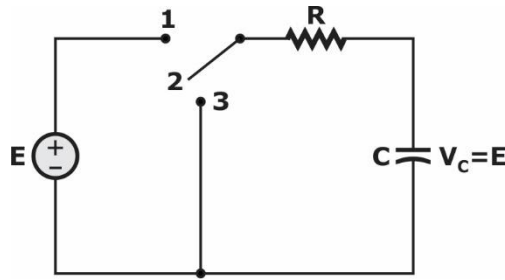

- A. 50 μ s
- B. 50 ms
- C. 150 ms
- D. 150 μ s

Ans. D

Sol. AT position 3,

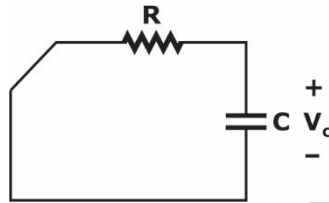

$$V_c = E e^{-t/\tau}$$

$$\tau = RC$$

$$= 10 \times 10^3 \times 0.005 \times 10^{-6}$$

$$= 50 \mu s$$

$$V_c = 100 e^{-t/50}$$

Now,

$$100 e^{-t/50} = 5$$

$$e^{-t/50} = 0.05$$

So,

$$t = 149.78$$

$$\approx 150 \mu s$$

8. A wye-connected generator is to be designed to supply a 20 kV three-phase line and supply a line current of 10 A at a lagging power factor of 0.8. How much reactive power (kVAR) should be supplied by the wye-connected generator?

- A. 200.4 kVAR
- B. 207.84 kVAR
- C. 277.12 kVAR
- D. 346.4 kVAR

Ans. B

Sol. Reactive power,

$$\theta = \sqrt{3} V_L I_L \sin \phi$$

$$\cos \phi = 0.6$$

$$\theta = \sqrt{3} \times 20 \times 10 \times 0.6$$

$$= 207.84 \text{ kVAR}$$

9. A cross-sectional view of a Printed Circuit Board (PCB) consisting of two conducting lands on the surface of a dielectric "Board above a reference ground plane is shown in the figure. The three-

conductor system characterized by a partial capacitance scheme is also shown. For the multiple conductor system, what is the capacitance matrix [C] ?

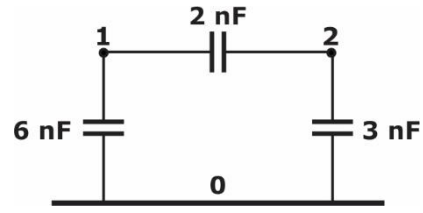
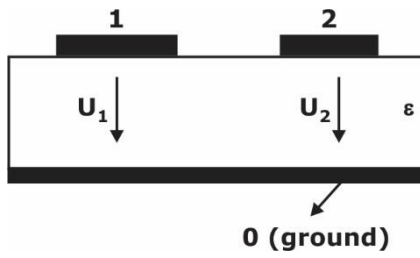

A. $[C] = \begin{bmatrix} -2 & 8 \\ 5 & -2 \end{bmatrix} \text{ nF}$

B. $[C] = \begin{bmatrix} -2 & 5 \\ 8 & -2 \end{bmatrix} \text{ nF}$

C. $[C] = \begin{bmatrix} 2 & -8 \\ -5 & 2 \end{bmatrix} \text{ nF}$

D. $[C] = \begin{bmatrix} 8 & -2 \\ -2 & 5 \end{bmatrix} \text{ nF}$

Ans. D

Sol.

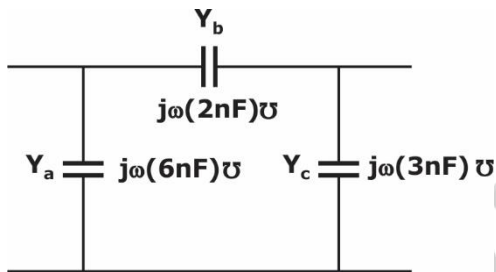

The capacitance matrix can be obtained from.

Admittance matrix

Here,

$$Z = \frac{1}{j\omega C} \Omega \text{ and } Y = j\omega C \vartheta = j\omega C \vartheta$$

$$[Y] = [j\omega C] \begin{bmatrix} Y_a Y_b & -Y_b \\ -Y_b & Y_b + Y_c \end{bmatrix}$$

$$= j\omega \begin{bmatrix} (6+2)\text{nF} & -2\text{nF} \\ -2\text{nF} & (3+20)\text{nF} \end{bmatrix}$$

$$= [C] = \begin{bmatrix} 8 & -2 \\ -2 & 5 \end{bmatrix} \text{ nF}$$

10. The two-wattmeter method produces wattmeter readings $P_1 = 1500 \text{ W}$ and $P_2 = 2500 \text{ W}$ when connected to a delta-connected load. What is the per-phase reactive power if the line voltage is 220 V?

- A. 3117 VAR
- C. 577.3 VAR

- B. 311.7 VAR
- D. 5773 VAR

Ans. C

Sol. $W_1 = 1500 \text{ W}$

$W_2 = 2500 \text{ W}$

The reactive power, $\theta = \sqrt{3} V_L I_L \sin \phi \text{ VAR}(3-\phi)$

$$\begin{aligned}
 \theta &= \sqrt{3}(W_1 - W_2) \\
 &= \sqrt{3}(1500 - 2500) \\
 \theta_{3-\phi} &= -1732.05 \text{ VAR} \\
 \theta_{1-\phi} &= \frac{1732.05}{3} \\
 &= 577.35 \text{ VAR}
 \end{aligned}$$

11. A three-phase balanced star-connected motor draws a real power of 5.6 kW from the line voltage of 220 V and the line current of 18.2 A. What is the approximate power factor of this motor?

- | | |
|-----------|-----------|
| A. 0.6075 | B. 0.8075 |
| C. 0.4075 | D. 0.2075 |

Ans. B

Sol. 3-phase power $P = \sqrt{3} V_L I_L \cos \phi$

$$5.6 \times 10^3 = \sqrt{3} \times 220 \times 18.2 \times \cos \phi$$

$$\cos \phi = 0.8075$$

12. A circuit composed with series combination of sinusoidal voltage so $V_s = 3 \cos(100t - 3^\circ)V$, a 500Ω resistor, a 30 mH inductor and an unknown impedance. What is the value of unknown impedance (Z_L) if the voltage source delivers maximum average power?

- | | |
|-----------------------|----------------------|
| A. $500 - j30 \Omega$ | B. $500 + j3 \Omega$ |
| C. $500 - j3 \Omega$ | D. $500 + j3 \Omega$ |

Ans. C

Sol. To deliver maximum average power

$$Z_L = Z_{Th}$$

$$Z_{Th} = R_{Th} + jX_{Th}$$

$$= 500 + j3$$

$$Z_L = 500 - j3$$

13. Which one of the following is used to protect the standard cell and galvanometer against over currents?

- A pressure coil in series
- A current coil in parallel
- A resistance in series
- A resistance in parallel

Ans. C

Sol. Potentiometer

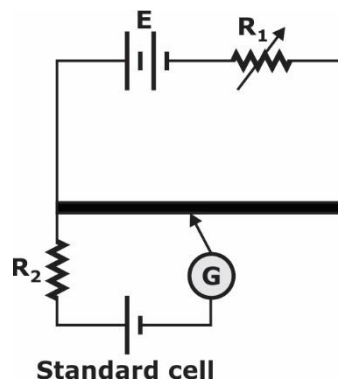

To protect galvanometer and standard cell a resistance (R_2) should be connected in series as shown.

∴ option (C)

14. In the measurement of a low resistance using a potentiometer, voltage drop across the low resistance under test is 0.4 V, voltage drop across 0.1Ω standard resistance is 1V. What is the power loss in unknown resistance?

A. 0.04 W

B. 0.4 W

C. 4 W

D. 40 W

Ans. C

Sol.

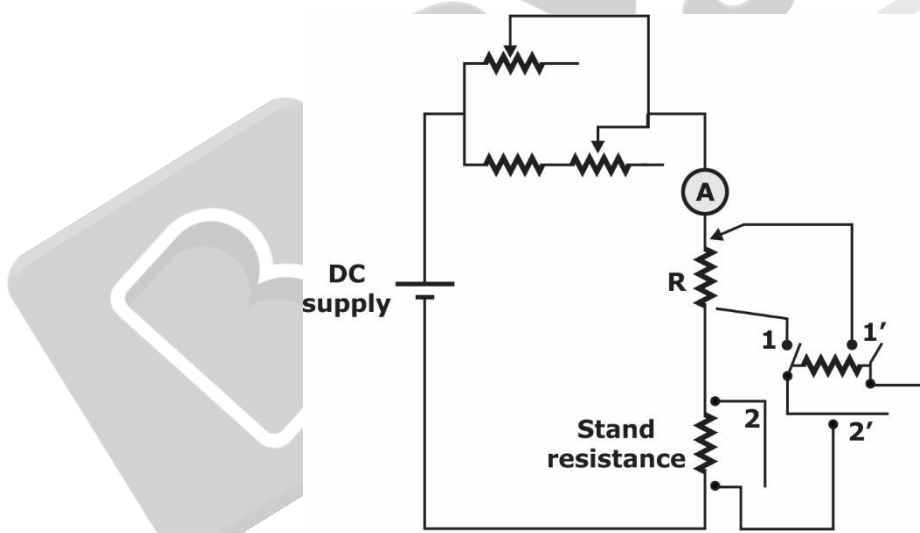

$$V_R = I_R R \text{ and } V_s = I \propto S$$

On equating V_R and V_s

$$\frac{V_R}{V_s} = \frac{IR}{IS}$$

$$\frac{0.4 \text{ V}}{1 \text{ V}} = \frac{R}{0.1}$$

$$R = 0.4 \times 0.1$$

$$R = 0.04\Omega \leftarrow \text{unknown resistance}$$

$$\text{The power loss, } P = \frac{V^2}{R} = \frac{(0.4)^2}{0.04} = 4 \text{ watts}$$

15. Consider the following statements:

- 1. Potentiometer is the usual basis for calibration of voltmeters, ammeters and wattmeters.
- 2. The potentiometers may not be used for measurement of current, power and resistance.

Which of the above statements is/are correct?

- A. 1 only
- B. 2 only
- C. Both 1 and 2
- D. Neither 1 nor 2

Ans. A

Sol. Potentiometer can be used to calibrate voltmeters. Ammeters and wattmeters [statement-1 is correct] potentiometer can be used to measure resistance, current and voltage and power [statement-2 is false].

16. A simple slide wire is used for measurement of current in a circuit. The voltage drop across a standard resistor of 0.1Ω is balanced at 75 cm. What is the magnitude of current in the circuit if the standard cell emf of 1.45 V is balanced at 50 cm?

- A. 21.75 A
- B. 10.87 A
- C. 9.66 A
- D. 4.83 A

Ans. C

Sol. Slide wire with standard cell

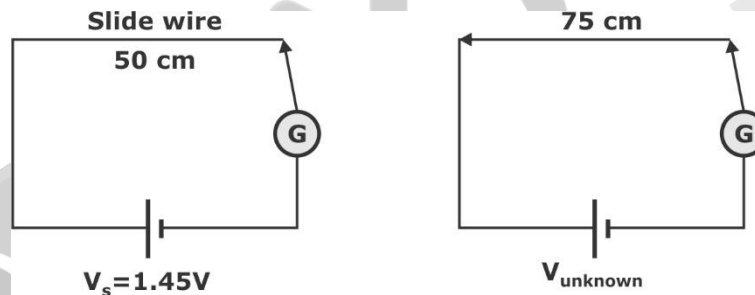

Voltage across 50 cm = 1.45 V

$$V_{\text{unknown}} = \frac{75}{50} \times 1.45 = 2.175 \text{ V}$$

$$= 2.175 \text{ V}$$

∴ The magnitude of current in circuit is

$$I = \frac{V_{\text{unknown}}}{R} = \frac{2.175}{0.1} = 21.75 \text{ Amp's}$$

17. Which one of the following methods is **not** used in measurement of high resistance?

- A. Direct deflection method
- B. Megohm bridge method
- C. Megger method
- D. Kelvin double bridge method

Ans. D

Sol. For measuring high resistance, we use

- (i) Loss of charge method
- (ii) Mega ohm bridge method

- (iii) Megger method
- (iv) Direct deflection method

Note: Kelvin’s double bridge method is used for low resistance.

- 18.** Which one of the following is intended for the rapid measurement of the winding resistances of machines and transformers?
- A. Direct deflection
 - B. Wheatstone bridge
 - C. Megger
 - D. Kelvin bridge ohmmeter

Ans. D

Sol. The winding resistance is usually low ($<1\Omega$)
∴ To measure low resistance, kelvin’s double’s bridge is used.

- 19.** A highly sensitive galvanometer can detect a current as low as 0.1 nA. This galvanometer is used in a Wheatstone-bridge as a detector. Each arm of the bridge has a resistance of 1 kΩ. The input voltage applied to the bridge is 20 V. What is the smallest change in resistance which can be detected, if the resistance of the galvanometer can be neglected compared to the internal resistance of the bridge?
- A. 10 mΩ
 - B. 10 μΩ
 - C. 20 mΩ
 - D. 20 μΩ

Ans. D

Sol.

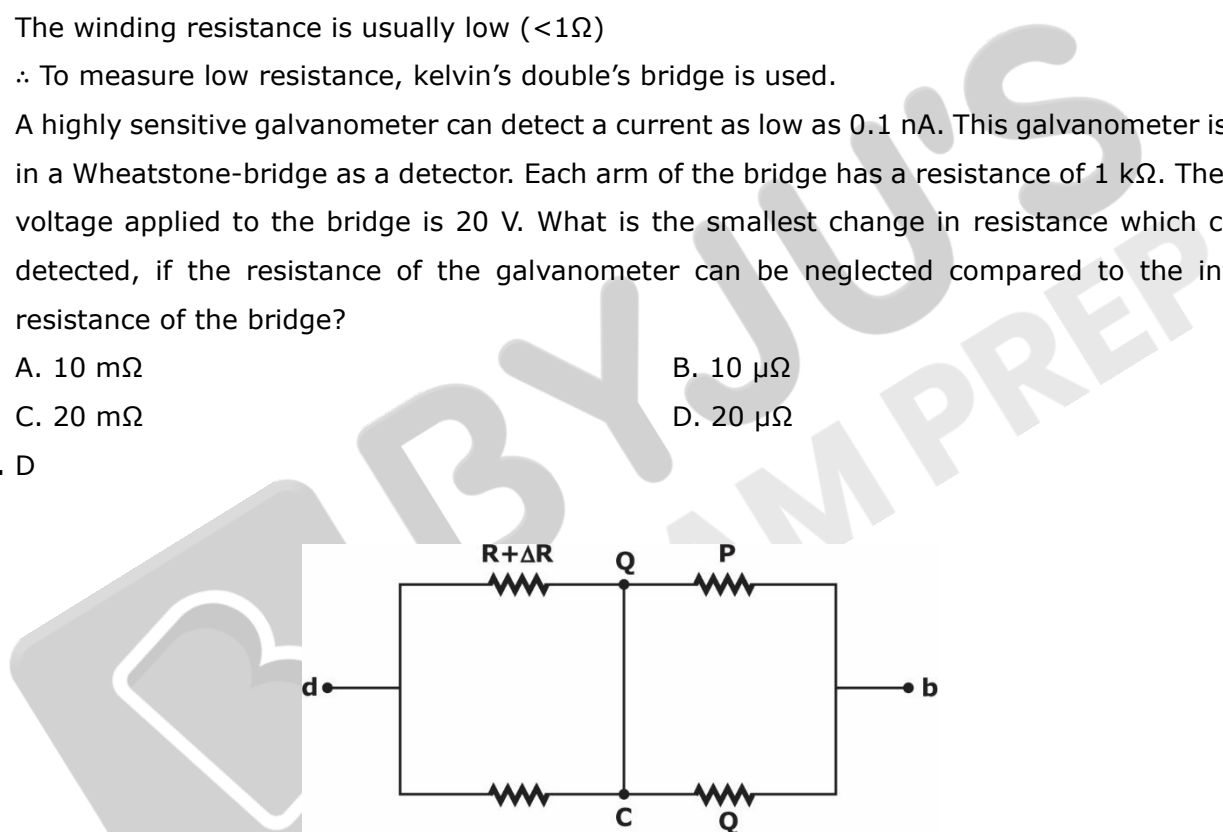

$$R_{ab} = R_0 = \frac{RS}{R + S} + \frac{PQ}{P + Q}$$

Here $\Delta R \ll R$

For a bridge with equal arm resistances

$$P = Q = R = S = 1K; R_0 = R = 1 k\Omega$$

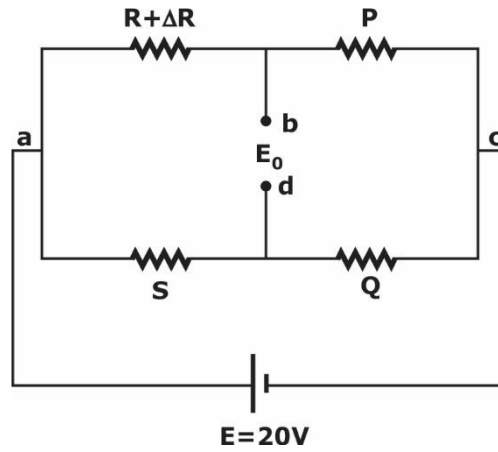

$$E_0 = \frac{E(\Delta R)}{4R} \text{ [can be obtained by voltage division and KVL]}$$

$$= 20 \times \frac{\Delta R}{4(1K)}$$

$$E_0 = (5m)\Delta R$$

Now, the current through galvanometer

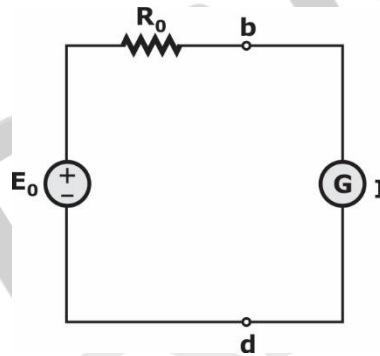

$$I_0 = \frac{E_0}{R_0} = \frac{(5m)\Delta R}{(1K)}$$

$$(0.1 \times 10^{-19})(1 \times 10^3) = (5 \times 10^{-3})\Delta R$$

$$\Delta R = 20 \mu\Omega$$

20. Which one of the following methods used in measurement of low resistance?

- A. Direct deflection method
- B. Ammeter voltmeter method
- C. Potentiometer method
- D. Kelvin double bridge method

Ans. C

Sol. Direct deflection method is used for high resistance but not for low resistance.

Whereas, ammeter-voltmeter method, potentiometer method and kelvin's double bridge is used for measurement of low resistance.

21. A regular Wheatstone bridge is used to measure high resistance. The bridge has ratio arms of $10,000\Omega$ and 10Ω . The adjustable arm has a maximum value of $10,000 \Omega$. A battery of $10 V$ emf

and negligible resistance is connected from the junction of ratio arms to the opposite corner. What is the maximum resistance that can be measured by this arrangement?

- A. 10 kΩ
- B. 10 MΩ
- C. 100 kΩ
- D. 100 MΩ

Ans. B

Sol.

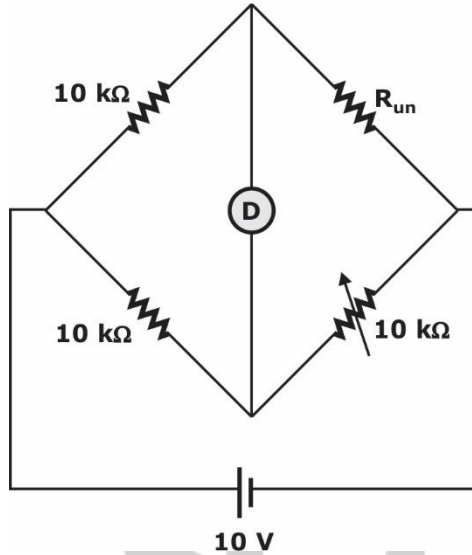

Wheatstone bridge during balance

$$(10k)(10k) = (R_{un}) \times 10$$

$$R_{un} = 10 \text{ M}\Omega$$

Option (B) is correct.

22. A resistance of approximately 3000 Ω is needed to balance a bridge. It is obtained on a 5 dial resistance box having steps of 1000 Ω, 100 Ω, 10 Ω, 1 Ω and 0.1Ω. The measurement is to be guaranteed to 0.1 percent. For this accuracy, how many of these dials would it be worth to adjust?

- A. 2997 Ω to 3003 Ω
- B. 3000 Ω to 3006 Ω
- C. 2994 Ω to 3000 Ω
- D. 2996 Ω to 3002 Ω

Ans. A

Sol. To get resistance of $300 \pm 0.1\%$

i.e., $3000 \times \frac{\pm 0.1}{100} = \pm 3\Omega$

$\therefore 3000 \pm 2997 \text{ to } 2003\Omega$

On the five dial resistance box, we need to adjust 1000Ω dial in 3 steps out of 5 steps whereas the remaining other dials should be kept at zero.

23. Consider the following statements:

1. Campbell’s bridge measures an unknown mutual inductance in terms of a standard mutual inductance.

2. Campbell’s bridge is used for measurement of self-inductance in terms of a standard mutual inductance.

Which of the above statements is/are correct?

- A. 1 only
- B. 2 only
- C. Both 1 and 2
- D. Neither 1 nor 2

Ans. B

Sol. Heavi side campbell’s bridge is used for measurement of self-inductance in terms of standard mutual inductance [only statement-2 is correct]

24. Consider the following statements:

- 1. Carey Foster bridge is used for measurement of capacitance in terms of a standard mutual inductance.
- 2. Heydweiller bridge is used for measurement of mutual inductance in terms of a standard mutual inductance.

Which of the above statements is/are correct?

- A. 1 only
- B. 2 only
- C. Both 1 and 2
- D. Neither 1 nor 2

Ans. D

Sol. Carey foster bridge modified by Hegdweiller for two opposite purposes.

(i) Measurement of capacitance in terms of standard mutual inductance. In this case, the bridge is called as Carey foster bridge. So statement-1 is correct.

(ii) Measurement of mutual inductance in terms of standard capacitance. In this case, the bridge is called as Heydweiller bridge. So, statement-2 is wrong.

25. A benchmark program is run on a 200 MHz processor. The executed program consists of 1 million instruction executions, with the following instruction mix and clock cycle count:

Instruction type	Instruction count (Millions)	Cycles per instruction
Arithmetic and logic	8	1
Load and store	4	3
Branch	2	4
Others	4	3

What is the effective MIPS rate for the given program?

- A. 90
- B. 70
- C. 110
- D. 80

Ans. A

Sol. Effective MIPS = $\frac{\text{Clock frequency}}{\text{CPI} \times 10^6}$

Instruction type	Instruction count (millions)	Cylinder per instruction
ALU	8	1
Load and store	4	3
Branch	2	4
Other	4	3
	18 m instruction	

Clock cycle = $(8 \times 1 + 4 \times 3 + 2 \times 4 + 4 \times 3) \times 10^6$

$(8 + 12 + 8 + 12) \times 10^6$

= 40×10^6 cycle

CPI = $\frac{40 \times 10^6}{2.22 \times 10^6} = 2.22$ CPI

MIPS = $\frac{200 \times 10^6}{2.22 \times 10^6} = 90.09 \approx 90$ MIPS

= 90 MIPS

26. What is the exponent length in bits for IEEE double-precision floating point format?

- A. 32 bits
- B. 8 bits
- C. 16 bits
- D. 11 bits

Ans. D

Sol. 11 bits

27. Which one of the following instruction formats is designed to be a large-scale time-shared system, with an emphasis on making system easy to program, even if additional hardware expense was involved?

- A. PDP-8
- B. PDP-10
- C. PDP-6
- D. PDP-12

Ans. D

Sol. The PDP-10 instruction format is designed to be a large-scale time-shared system, with an emphasis on making the system easy to program, even if additional hardware expense was involved.

28. Which one of the following statements is correct for machine parallelism?

- A. It is a measure of the ability of the processor to take disadvantage o instruction-level parallelism.

- B. It is determined by the frequency of true data dependencies and procedural dependencies in the code.
- C. It is determined by the number of instructions that can be fetched and executed at the same time and by the speed and sophistication of the mechanisms that the processor uses to find independent instructions.
- D. It is determined by the time until the result of an instruction is available for use as an operand in a subsequent instruction.

Ans. C

Sol.

- 29.** Consider a main memory consisting of 4K blocks, a cache memory consisting of 64 blocks, and a block size of 32 words. Compute the number of bits in the main memory address using direct-mapped cache technique.
- A. 16
 - B. 17
 - C. 19
 - D. 14

Ans. B

Sol. Main memory consisting of like block

Block size = 32 words

⇒ Main memory size = $4 \times 2^{10} \times 32$
 2^{17} words

Number of bits in main memory address = $\log_2(2^{17}) = 17$ bits

- 30.** Which one of the following methods is used when the processor issues an I/O command, continues to execute other instructions, and is interrupted by the I/O module when the latter has completed its work?
- A. Interrupt-driven I/O
 - B. I/O device controller
 - C. I/O channel processor controller
 - D. Programmed I/O

Ans. A

Sol. The method used when the processor, reverts an i/o command, continues to execute other instruction and is interrupted by the i/o module when latter has completed its work is interrupt driven i/o.

- 31.** Which one of the following statements is correct for atomic data?
- A. Aggregation of atomic and composite data into a set with defined relationships are validated.
 - B. Heterogeneous combination of data into a single structure with an identified key is validated.
 - C. Homogeneous combination of data into a single structure with an identified key is validated,
 - D. It is a data that consists of a single piece of information; that is, they cannot be divided into other meaningful pieces of data.

Ans. D

Sol. Atomic data consists of a single piece of information; that is, they cannot be divided into other meaningful pieces of data.

Atomic data is indivisible and cannot be broken down further into smaller meaningful data pieces. Examples of atomic data include integers, floating-point numbers, characters, and Boolean values.

32. Consider the four processes $P_1 = 6$, $P_2 = 8$, $P_3 = 7$, and $P_4 = 3$ with the length of the CPU burst time given in milliseconds and all four processes arrive at time 0. What is the average waiting time for these processes with the shortest job first algorithm?

- A. 5 ms
- B. 7 ms
- C. 9 ms
- D. 11 ms

Ans. B

Sol.

	Arrival time	Burst time
P_1	0	6
P_2	0	8
P_3	0	7
P_4	8	3

Shorter job first:

Gantt chart

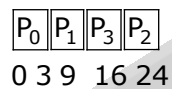

Average waiting time

$$\frac{0 + 3 + 4 + 16}{4} = \frac{28}{4} = 7 \text{ ms}$$

33. The processes that are residing in main memory and are ready and waiting to execute are kept on a list called the ready queue. Then, this queue is generally stored as

- A. a double ended queue
- B. a priority queue
- C. a linked list
- D. a double ended list

Ans. B

Sol. Ready queue is used in the process scheduling will be priority queue.

34. When a process creates a new process using the fork () operation, which one of following states is shared between the process and the child process?

- A. Stack N
- B. Heap
- C. Linked list
- D. Shared memory segments

Ans. D

Sol. Only the shared memory segments are shared between the parent process and the newly forked child process.

35. Consider the following statements regarding thread pool:

1. It is to create a number of threads at process startup and place them into a pool, where they sit and wait for work.
2. A thread pool limits the number of threads that exist at any one point and this is particularly important on systems that cannot support a large number of concurrent threads.
3. Once the summation thread is created, the parent must wait for it to complete before outputting the value of sum, as the value is set by the summation thread.
4. It allocates memory and initializes a new thread in the JVM.

Which of the above statements are correct?

- A. 1 and 2 only
- B. 3 and 4 only
- C. 1 and 3 only
- D. 1, 2, 3 and 4

Ans. A

Sol. 1, and 2 are correct

The first statement is correct. A thread pool is created at the process startup and it consists of a group of pre-initialized threads that are ready to be used to execute tasks.

The second statement is also correct. A thread pool is used to limit the number of threads that exist at any point in time, which is useful for systems that cannot support a large number of concurrent threads.

The third statement is not always true. While it is true that the parent thread must wait for the summation thread to complete before outputting the value of sum, the value is not necessarily set by the summation thread. It could be set by a different thread that is part of the thread pool.

The fourth statement is not true. A thread pool does not allocate memory and initialize a new thread in the JVM. Instead, it reuses pre-initialized threads from the thread pool, which can improve performance and reduce overhead.

36. Which one of the following is used for recognizing the magnetic encoding numbers printed at the bottom of a cheque?

- A. Optical Mark Recognition
- B. Magnetic Ink Character Recognition
- C. Barcode Reader
- D. Optical Character Recognition

Ans. B

Sol. *

37. Consider the following statements regarding biasing of p-n junction:

1. The depletion layer width gets narrowed down on applied forward voltage.

2. A forward-biased p-n junction offers very high resistance to current flow.
3. The barrier potential increase when the junction is reverse biased.
4. Majority charge carrier's current is established in a forward-biased p-n junction.

Which of the above statement are correct?

- A. 1, 2, 3 and 4
- B. 2, 3 and 4 only
- C. 1, 3 and 4 only
- D. 3 and 4 only

Ans. C

Sol. Standard basic facts

38. Which one of the following is the correct representation of Boltzmann diode equation with standard notations? (where I is the diode current, V is the bias voltage, and V_T is the thermal voltage).

A. $I = I_0 \left(\frac{V}{e^{\eta V_T}} - 1 \right)$

B. $I = I_0 \left(\frac{V}{e^{\eta V_T}} + 1 \right)$

C. $I = I_0 \left(-\frac{V}{e^{-\eta V_T}} - 1 \right)$

D. $I = I_0 \left(-\frac{V}{e^{\eta V_T}} + 1 \right)$

Ans. A

Sol.

39. The common emitter configuration is widely used due to its

- A. low voltage and low power gain
- B. low voltage and high power gain
- C. high voltage and high power gain
- D. high voltage and low power gain

Ans. C

Sol. The CE configuration is widely used due to its high voltage and high power gain.

40. A silicon diode made, half-wave rectifier produces a maximum value of load current as 20 mA through a resistance of 1 kΩ. What is the PIV of the diode?

- A. 14.7 V
- B. 16.7 V
- C. 18.7 V
- D. 20.7 V

Ans. D

Sol. Assume a voltage drop of 0.7V across the silicon diode, the peak value of current, I_m is zoom A, through resistor of 1kΩ.

$$\therefore I_m = \frac{V_m - 0.7}{R}$$

$$20 \times 10^{-3} = \frac{V_m - 0.7}{1 \times 10^3}$$

$$V_{in} = 20 + 0.7 = 20.7 \text{ V}$$

41. Ripple factor for a half-wave and a full-wave rectifier circuits respectively are

- A. 0.48 and 1.21
- B. 0.37 to 2.12
- C. 1.21 and 0.48
- D. 2.12 and 0.37

Ans. C

Sol. The value of ripple factor in half wave rectifier is about 1.21 while in full wave rectifier is 0.482.

42. If a transistor has the value of common base current gain 0.98, then what is the value of common emitter current gain?

- A. 48
- B. 49
- C. 50
- D. 51

Ans. B

Sol. $\alpha = 0.98$

$\beta = ?$

$$\beta = \frac{\alpha}{1 - \alpha} = \frac{0.98}{1 - 0.98} = \frac{0.98}{0.02} = 49$$

43. The junction FET is a three terminal

- A. Voltage controlled voltage device
- B. current controlled voltage device
- C. voltage controlled current device
- D. current controlled current device

Ans. C

Sol. JFET is a three terminal voltage controlled current source. Because the output current (I_D) is proportional to V_{GS} and so it is called voltage controlled current source.

44. Consider the basic MOSFET circuit as shown in the figure with variable gate voltage. The MOSFET is given to have very large V_A , $V_T = 4V$, and $I_{DSS} = 8 \text{ mA}$. What is the value of i_D for $V_{GS} = 5V$? (Where V_A is a constant in the range of 30 V to 200 V).

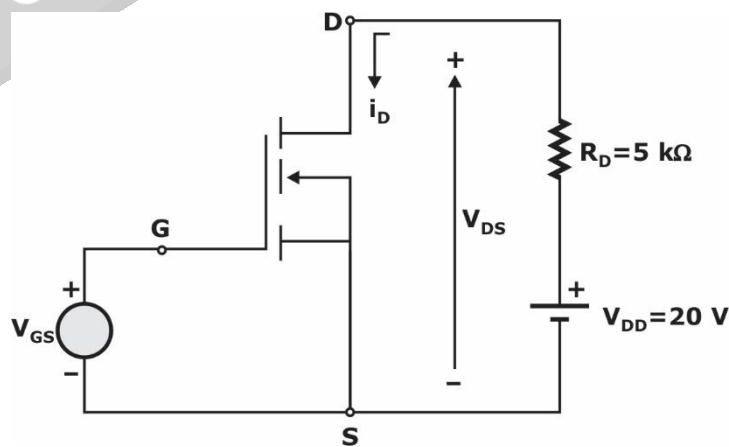

- A. 0.2 mA
- B. 0.5 mA
- C. 1.0 mA
- D. 2.0 mA

Ans. B

Sol. Given:

$$V_T = 4V$$

$$I_{DSS} = 8 \text{ mA}$$

$$V_{GS} = 5V$$

Given MOSFET is enhancement type MOSFET.

$$I_D = I_{DSS} \left[1 - \frac{V_{GS}}{V_T} \right]^2 \quad \dots(1)$$

Apply KVL at outer loop

$$-V_{DS} - I_D R_D + V_{DD} = 0$$

$$\Rightarrow I_D = \frac{-V_{DS} + V_{DD}}{R_D} \quad \dots(2)$$

Equating equations (i) and (ii),

$$\frac{V_{DD} - V_{DS}}{R_D} = I_{DSS} \left(1 - \frac{V_{GS}}{V_T} \right)^2$$

$$\frac{20 - V_{DS}}{5 \times 10^3} = 8 \times 10^{-3} \left(1 - \frac{5}{4} \right)^2$$

$$V_{DS} = 17.5V$$

$$\therefore I_D = \frac{20 - 17.5}{5 \times 10^3} = 0.5 \text{ mA}$$

45. Which one of the following is the correct circuit symbol representation of p-channel JFET?

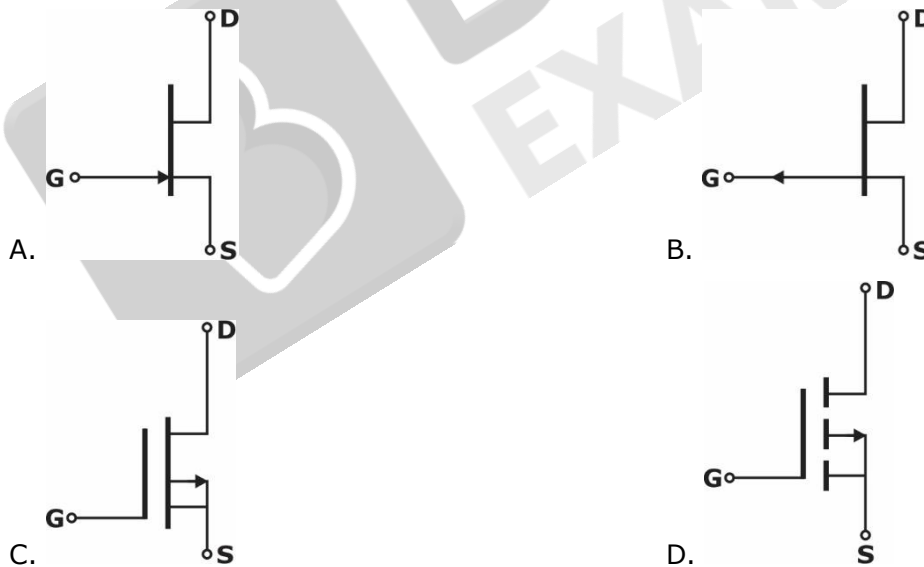

Ans. B

Sol.

46. Consider the following statements regarding FET amplifier configurations:

1. For common-source and common-drain configurations, $R_{in} = R_1 \parallel R_2$, be selected to be large' during bias design.

2. For the common-drain configuration, the voltage gain is generally less than unity or near unity.
3. For the common-gate configuration, the current gain cannot be larger than unity.

Which of the above statements is/are correct?

- A. 1 only
- B. 1 and 2 only
- C. 2 and 3 only
- D. 1, 2 and 3

Ans. D

Sol.

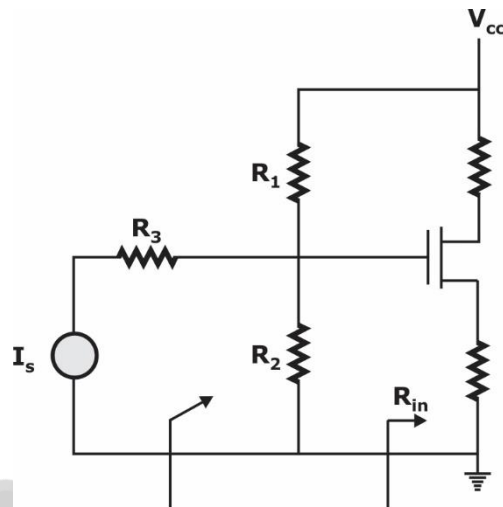

$R_1 || R_2$ Here we have very high input resistance i.e., $R_{in} = \infty$

- Input resistance seen by V_s is $R_1 || R_2 || R_{in}$ that results $R_1 || R_2$ and this value should be high in the range of $M\Omega$.
 \therefore For common-source and common drain configurations, $R_{in} = R_1 || R_2$ which can be related to be large during bias design. Statement 1 is correct.
 For common drain configuration which is similar to common collector configuration, voltage gain is less than unity or near unity
 \therefore statement 2 is correct
 For common gate configuration, current through drain and source is I_D and gate current is zero. So the current gain is unity.
 Statement 3 is correct.

- 47.** An amplifier has a bandwidth of 500 kHz and voltage gain of 100. What is the amount of negative feedback if the bandwidth is extended to 5 MHz?
- A. 9.0
 - B. 0.9
 - C. 0.09
 - D. 0.009

Ans. C

Sol. Bandwidth extended = $(1 + A/\beta) \times$ Bandwidth
 $5 \times 10^6 = (1 + 100\beta) \times 500 \times 10^3$

$$10 = 1 + 100 \beta$$

$$9 = 100 \beta$$

$$\beta = 0.09$$

48. An amplifier has an open loop voltage gain of 1000. If 10% negative voltage series feedback is used, what is the closed loop voltage gain?

A. 0.19

B. 1.9

C. 9.9

D. 0.99

Ans. C

Sol. Closed loop gain, $A_{CL} = \frac{A_{OL}}{1 + A_{OL}\beta}$

$$= \frac{1000}{1 + 1000 \times \frac{10}{100}}$$

$$= \frac{1000}{101} = 9.9$$

49. Which one of the following quantities is a material parameter?

A. Peridynamic lattice

B. Electrical elongation

C. Thermal elongation

D. Electrical conductivity

Ans. D

Sol. Among the given quantities, electrical conductivity is a material parameter.

50. The property of periodicity in crystal structure is repeated in three dimensions. The positive ions occupy-the corners of a cube as well as the centres of the cubic face. Then these crystals are called.

A. Face-centered cubic crystals

B. Body-centered cubic crystals

C. Halite-centered cubic crystals

D. Rock-salt-centered cubic crystals

Ans. A

Sol. The property of periodicity in crystal is the element structure is repeated in three dimensions. The positive ions occupy the corners of a cube as well as the centers of the cubic face. Then crystals are called face-centered cubic crystals.

51. The electrical conductivity depends on

A. the volume concentration of the holes and on their mobility

B. the volume concentration of the electrons of conduction and on their mobility

C. concentration of both electrons and protons

D concentration of electrons only

Ans. B

Sol. Conductivity, $\sigma = ne\mu$

$$\sigma \propto \mu (\because \text{mobility})$$

Also,

$$\sigma = \frac{1}{\rho} = \frac{V}{A^2R}$$

$$\sigma \propto V \text{ (Volume of concentration of electrons)}$$

- 52.** The classical theory of the diamagnetism of the bonded electrons in a free atom was elaborated by
- A. Langevin diamagnetism
 - B. Larmor diamagnetism
 - C. Lorentz diamagnetism
 - D. Thomson diamagnetism

Ans. A

Sol. The classical theory of the diamagnetism of the bonded electrons in a free atom was elaborated by Langevin diamagnetism

- 53.** Which one of the following is the process of heating a material to just below its melting point?
- A. Sinter
 - B. Squid
 - C. Josephson junction
 - D. Stripes

Ans. A

Sol. The process of heating a material to just below its melting point is called sinter.

- 54.** Which of the following are the mixtures of materials used for the sliding contacts which appear between the trolley and the trolley cable in the electrical traction of high braking power?
- A. Silver, Electrolytic copper, Lead with Zinc and Aluminum
 - B. Silver, Copper, Bronze with Beryllium and Cadmium
 - C. Silver, Copper, Lead with Zinc and Gold,
 - D. Silver, Electrolytic copper, Bronze with Zinc and Gold

Ans. A

Sol. The sliding contacts which appears between the trolley and trolley cable on the electrical traction is called pantograph and this is usually made of the mixture of silver, electrolytic copper, lead with Line and Aluminum.

- 55.** Which one of the following is the element exhibiting antiferromagnetism, at room temperature?
- A. Iron
 - B. Nickel
 - C. Chromium
 - D. cobalt

Ans. C

Sol. Chromium shows antiferromagnetism at room temperature whereas Iron (Fe), Cobalt (Co), and Nickel (Ni) shows ferromagnetism at room temperature.

- 56.** Electro-optic devices that emit radiations of different colours are called
- A. Opto-couplings
 - B. Photoresistors
 - C. Light emitting diodes
 - D. Void generators

Ans. C

Sol. Electro-optic devices that emit radiations of different colours are called light emitting diodes.

- 57.** The phenomenon where superconductivity in a material is suppressed by exceeding the maximum current the material can conduct (J_c) or the maximum magnetic field it can withstand (H_c) is called
- A. Sinter
 - B. Quench
 - C. Stripes
 - D. Proximity effect

Ans. B

Sol. The phenomenon where superconductivity in a material is suppressed by exceeding the maximum current the material can conduct (J_c) or the maximum magnetic field it can withstand (H_c) is called Quench.

58. Which one of the following corresponds to the variation of the rotation frequency of the electron when the external field is applied ?

- A. Langevin frequency
- B. Lorentz frequency
- C. Thomson frequency
- D. Larmor frequency

Ans. D

Sol. When the external field is applied, the angular momentum of the Orbiting elation is disturbed. So there will be an additional component in the orbiting frequency of an electron called as Larmor frequency.

59. Which one of the following agents is an intrinsic agent that influences conductivity in electro insulating materials ?

- A. Humidity
- B. The nature of the dielectric
- C. Temperature
- D. Pressure

Ans. A

Sol. During rainy season, the insulating property of an insulator is heavily reduced. This is due to the fact that conductivity property of insulator is heavily depend on humidity.

60. A semiconductor indium phosphide material behaves as an insulator at

- A. high temperature
- B. medium temperature
- C. normal room temperature
- D. very low temperature

Ans. D

Sol. Since, indium phosphide is a semiconductor it will behave as an insulator at very low temperature.

61. The general solution of the system is

$$\begin{aligned} 6x_1 - x_2 + x_3 &= 0 \\ x_1 - x_4 + 2x_5 &= 0 \\ x_1 - 2x_5 &= 0 \end{aligned}$$

A. $X = \alpha \begin{pmatrix} 1 \\ -\frac{1}{9} \\ 2 \\ -\frac{2}{3} \\ \frac{2}{3} \\ 1 \\ 0 \end{pmatrix} + \beta \begin{pmatrix} -\frac{11}{9} \\ \frac{13}{3} \\ 1 \\ \frac{1}{3} \\ 0 \\ 1 \end{pmatrix}$

B. $X = \alpha \begin{pmatrix} 1 \\ -\frac{1}{9} \\ 2 \\ -\frac{2}{3} \\ \frac{2}{3} \\ 1 \\ 0 \end{pmatrix} + \beta \begin{pmatrix} -\frac{11}{9} \\ \frac{13}{3} \\ 1 \\ \frac{1}{3} \\ 0 \\ 1 \end{pmatrix} + \gamma \begin{pmatrix} -\frac{11}{9} \\ \frac{13}{3} \\ 0 \\ \frac{1}{3} \\ 1 \\ 1 \end{pmatrix}$

C. $X = \alpha \begin{pmatrix} 1 \\ -\frac{1}{9} \\ 2 \\ -\frac{2}{3} \\ \frac{2}{3} \\ 1 \\ 0 \end{pmatrix} + \beta \begin{pmatrix} -\frac{11}{9} \\ \frac{13}{3} \\ 1 \\ \frac{1}{3} \\ 0 \\ 1 \end{pmatrix} + \gamma \begin{pmatrix} -\frac{11}{9} \\ 1 \\ 0 \\ \frac{1}{3} \\ 1 \end{pmatrix}$

D. $X = \alpha \begin{pmatrix} 1 \\ -\frac{1}{9} \\ 0 \\ \frac{2}{3} \\ \frac{1}{3} \\ 1 \\ 0 \end{pmatrix} + \beta \begin{pmatrix} -\frac{11}{9} \\ \frac{13}{3} \\ 1 \\ \frac{1}{3} \\ 1 \\ 1 \end{pmatrix}$

Ans. *

Sol. *

62. If the eigenvalues of the matrix $A = \begin{pmatrix} 5 & -2 \\ m & -6 \end{pmatrix}$ are 3 and -4, then what is the value of m?

- A. 6
- B. 4
- C. 8
- D. 9

Ans. D

Sol. $\lambda_1 = 3, \lambda_2 = -4$
 $\lambda_1 \cdot \lambda_2 = |A| = \begin{vmatrix} 5 & -2 \\ m & -6 \end{vmatrix}$
 $3x - 4 = -30 + 2m$
 $2m = 18$
 $m = 9$

63. If $z = f(x + ct) + \phi(x - ct)$, then $\frac{\partial^2 z}{\partial t^2} =$

- A. $c \frac{\partial^2 z}{\partial x^2}$
- B. $c^2 \frac{\partial^2 z}{\partial x^2}$
- C. $-c^2 \frac{\partial^2 z}{\partial x^2}$
- D. $-c \frac{\partial^2 z}{\partial x^2}$

Ans. B

Sol. $z = f(x + ct) + \phi(x - ct)$

$$\frac{\partial z}{\partial t} = cf'(x + ct) + \phi'(x - ct)(-c)$$

$$\frac{\partial^2 z}{\partial t^2} = c^2 f''(x + ct) + c^2 \phi''(x - ct) \quad \dots(i)$$

Now, $\frac{\partial z}{\partial x} = f'(x + ct) + \phi'(x - ct)$

$$\frac{\partial^2 z}{\partial x^2} = f''(x + ct) + \phi''(x - ct) \quad \dots(ii)$$

By (1) & (2)

$$\frac{\partial^2 z}{\partial t^2} = c^2 \frac{\partial^2 z}{\partial x^2}$$

64. The volume of the solid enclosed between the paraboloids $z = 5x^2 + 5y^2$ and $z = 6 - 7x^2 - y^2$ is

- A. $\frac{3\pi}{2\sqrt{2}}$
- B. $\frac{3\pi}{\sqrt{2}}$
- C. $\frac{3\pi^2}{\sqrt{2}}$
- D. $\frac{3\pi^3}{\sqrt{2}}$

Ans. B

Sol. $5x^2 + 5y^2 = 6 - 7x^2 - y^2$
 $12x^2 + 6y^2 = 6 \Rightarrow 6y^2 = 6 - 12x^2$
 $\frac{x^2}{(1/2)} + \frac{y^2}{1} = 1 \Rightarrow 6y^2 = 1 - 2x^2$
 $R \equiv \frac{x^2}{(1/\sqrt{2})^2} + \frac{y^2}{1^2} = 1 \quad 2x^2 + y^2 = 1$

$$\begin{aligned}
 V &= \iint_R [(6 - 7x^2 - y^2) - (5x^2 + 5y^2)] dx dy \\
 &= \iint (6 - 12x^2 - 6y^2) dx dy \\
 &= 6 \int_{x_1}^{x_2} \int_{y_1}^{y_2} (1 - 2x^2 - y^2) dy \cdot dx
 \end{aligned}$$

Put

$$\begin{aligned}
 x &= \frac{u}{\sqrt{2}}, \quad y = v \\
 &= 1 - (2x^2 + y^2) \\
 &= 1 - \left(2 \frac{u^2}{2} + v^2\right) \\
 &= 1 - (u^2 + v^2) \\
 J &= \frac{\partial(x, y)}{\partial(u, v)} = \begin{vmatrix} \frac{1}{\sqrt{2}} & 0 \\ 0 & 1 \end{vmatrix} = \frac{1}{\sqrt{2}} \\
 &= 6 \iint_R [1 - (u^2 + v^2)] J \cdot du dv
 \end{aligned}$$

Put

$$\begin{aligned}
 u^2 + v^2 = r^2 &\Rightarrow 2x^2 + y^2 \leq 1 \\
 u^2 + v^2 &\leq 1 \\
 \frac{6}{\sqrt{2}} \iint_R (1 - r^2) r dr d\theta \\
 &= 3\sqrt{2} \left[\frac{r^2}{2} - \frac{r^4}{4} \right]_{r=0}^{r=1} [\theta]_0^{2\pi} \\
 &= 3\sqrt{2} (2\pi - 0) \left[\frac{1}{2} - \frac{1}{4} \right] \\
 &= \frac{6\sqrt{2}\pi}{4} = \frac{3\sqrt{2}\pi}{2} = \frac{3}{\sqrt{2}} \pi
 \end{aligned}$$

65. The Fourier series representation of $f(x) = \begin{cases} x, & 0 \leq x \leq \pi \\ \pi, & \pi \leq x \leq 2\pi \end{cases}$ is

- A. $f(x) = \frac{3\pi}{4} - \frac{2}{\pi} \sum_{n=1}^{\infty} \frac{\cos(2n-1)x}{(2n-1)^2} - \sum_{n=1}^{\infty} \frac{\sin nx}{n}$ for $0 \leq x \leq 2\pi$
- B. $f(x) = \frac{3\pi}{4} - \frac{2}{\pi} \sum_{n=1}^{\infty} \frac{\cos(2n-1)x}{(2n-1)^2} + \sum_{n=1}^{\infty} \frac{\sin nx}{n}$ for $0 \leq x \leq 2\pi$
- C. $f(x) = \frac{3\pi}{4} - \frac{2}{\pi} \sum_{n=1}^{\infty} \frac{\cos(2n-1)x}{(2n-1)^4} - \sum_{n=1}^{\infty} \frac{\sin nx}{n}$ for $0 \leq x \leq 2\pi$
- D. $f(x) = \frac{3\pi}{4} + \frac{2}{\pi} \sum_{n=1}^{\infty} \frac{\cos(2n-1)x}{(2n-1)^2} - \sum_{n=1}^{\infty} \frac{\sin nx}{n}$ for $0 \leq x \leq 2\pi$

Ans. A

Sol. $f(x) = \begin{cases} x; & 0 \leq x \leq \pi \\ \pi; & \pi \leq x \leq 2\pi \end{cases}$

$$T = 2\pi \Rightarrow \omega_0 = \frac{2\pi}{T} = 1$$

$$a_0 = \frac{1}{T} \int_T f(x) dx = \frac{1}{2\pi} \int_0^{2\pi} f(x) dx$$

$$= \frac{1}{2\pi} \left[\frac{1}{2} \times \pi \times \pi + \pi \times \pi \right]$$

$$= \frac{1}{2\pi} \left[\frac{3\pi^2}{2} \right] = \frac{3}{4} \pi$$

$$a_n = \frac{2}{T} \int_T f(x) \cdot \cos(n\omega_0 x) dx$$

$$= \frac{2}{2\pi} \left[\int_0^\pi x \cdot \cos(nx) dx + \int_\pi^{2\pi} \pi \cdot \cos(nx) dx \right]$$

$$a_n = \frac{1}{\pi} \left[\left\{ x \left(\frac{\sin nx}{n} \right) - 1 \cdot \left(\frac{-\cos nx}{n^2} \right) \right\}_0^\pi + \pi \left(\frac{\sin n\pi}{n} \right)_\pi^{2\pi} \right]$$

$$= \frac{1}{\pi} \left[\left\{ 0 + \frac{(-1)^n}{n^2} \right\} - \left\{ 0 + \frac{1}{n^2} \right\} + \frac{\pi}{n} (0 - 0) \right]$$

$$= \frac{1}{\pi n^2} [(-1)^n - 1]$$

$$a_n = \begin{cases} \frac{-2}{\pi n^2}; & n = \text{odd} \\ 0; & n = \text{even} \end{cases}$$

And

$$b_n = \frac{2}{T} \int_T f(x) \cdot \sin(n\omega_0 x)$$

$$= \frac{2}{2\pi} \left[\int_0^\pi x \sin(n \cdot x) \cdot dx + \int_\pi^{2\pi} \pi \cdot \sin(nx) dx \right]$$

$$= \frac{1}{\pi} \left[\left\{ x \left(-\frac{\cos nx}{n} \right) + \frac{1 \cdot \sin nx}{n^2} \right\}_0^\pi + \pi \left(-\frac{\cos nx}{n} \right)_\pi^{2\pi} \right]$$

$$= \frac{1}{\pi} \left[\frac{-\pi}{n} (-1)^n + 0 - \frac{\pi}{n} (1 - (-1)^n) \right]$$

$$= \frac{1}{\pi} \left(-\frac{\pi}{n} \right)$$

$$b_n = -\frac{1}{n}$$

$$f(x) = a_0 + \sum_{n=1}^{\infty} a_n \cos(n\omega_0 x) + \sum_{n=1}^{\infty} b_n \sin(n\omega_0 x)$$

$$f(x) = \frac{3\pi}{4} - \frac{2}{\pi} \sum_{n=1,3,5,\dots}^{\infty} \frac{1}{n^2} \cos(nx) - \sum_{n=1}^{\infty} \frac{\sin(nx)}{n}$$

$$f(x) = \frac{3\pi}{4} - \frac{2}{\pi} \sum_{n=1}^{\infty} \frac{\cos(2n-1)x}{(2n-1)^2} - \sum_{n=1}^{\infty} \frac{\sin nx}{n}$$

66. The value of $\int_{\gamma} e^{1/z} dz$ where γ is a closed path enclosing the origin is

- A. $-2\pi i$
- B. $2\pi i$
- C. $-\pi i$
- D. πi

Ans. B

Sol. $e^{1/z} = 1 + \left(\frac{1}{z}\right) + \frac{\left(\frac{1}{z}\right)^2}{2!} + \frac{\left(\frac{1}{z}\right)^3}{3!} + \dots$

Res of $e^{1/z}$ at 'z = 0' = coefficient of z in $\left(\frac{1}{z}\right)$

By Cauchy's Residue Theorem

$$\oint_{\gamma} e^{1/z} dz = 2\pi i(1) = 2\pi i$$

67. Let $f(z) = 2iz + 6\bar{z}$. the value of f at $z = \frac{1}{2} + 4i$ is.

- A. $5 - 23i$
- B. $5 + 23i$
- C. $-5 - 23i$
- D. $-5 + 23i$

Ans. C

Sol.

$$f(z) = 2iz + 6\bar{z}$$

Put,

$$z = x + iy \text{ \& \ } \bar{z} = x - iy$$

$$f(z) = 2i(x + iy) + 6(x - iy)$$

$$= 2ix + 2i^2y + 6x - 6iy$$

$$f(z) = (6x - 2y) + i(2x - 6y)$$

$$\text{at } z = \frac{1}{2} + 4i$$

$$f(z)|_{z=\frac{1}{2}+4i} = (3 - 8) + i(1 - 24)$$

$$= -5 - 23i$$

68. What is the root of the equation $x \sin x + \cos x = 0$ up to four decimal places ?

- A. 2.7689
- B. 2.7784
- C. 2.7498
- D. 2.7984

Ans. D

Sol. $f(x) = x \cos x + \sin x - \sin x$

$$f'(x) = x \cos x$$

$$f(2.7) = 0.2498$$

By Newton Raphson

$$x_{n+1} = x_n - \frac{f(x_n)}{f'(x_n)}$$

$$x_1 = 2.7 - \frac{f(2.7)}{f'(2.7)} = 2.8023$$

$$x_2 = 2.8023 - \frac{f(2.8023)}{f'(2.8023)} = 2.7984$$

69. Which one of the following is the general integral of the linear partial differential equation $(y + xz) p - (x + yz) q = (x^2 - y^2) r$?

- A. $F(x^2 + y^2 - z^2, xy + z) = 0$
- B. $F(x^2 - y^2 - z^2, xz + y) = 0$
- C. $F(x^2 + y^2 - z^2, xz + y) = 0$
- D. $F(x^2 + y^2 - z^2, zy + x) = 0$

Ans. A

Sol. $\frac{dx}{P} = \frac{dy}{Q} = \frac{dz}{R}$

$$\frac{dx}{y + xz} = \frac{dy}{-(x + yz)} = \frac{dz}{x^2 - y^2} \quad \dots(1)$$

Using multiplies $x, y, 1$

$$\begin{aligned} \text{From each ratio of equation 1} &= \frac{xdx + ydy + dz}{(xyy + x^2z) - xy - y^2z + x^2 - y^2} \\ &= \frac{xdx + ydy + dz}{z(x^2 - y^2) + (x^2 - y^2)} \\ &= \frac{xdx + ydy + dz}{(z + 1)(x^2 - y^2)} \quad \dots(2) \end{aligned}$$

Consider,

$$\frac{dz}{x^2 - y^2} = \frac{xdx + ydy + dz}{(z + 1)(x^2 - y^2)}$$

$$(z + 1)dz = xdx + ydy + dz$$

Int. both sides

$$\frac{x^2}{2} + \frac{y^2}{2} - \frac{z^2}{2} = 0 + c_1$$

$$4 \equiv x^2 + y^2 - z^2 = a$$

Using multiplies $y, x, 1$ in (1)

$$\begin{aligned} \text{Each ratio of 1} &= \frac{ydx + xdy + dz}{y^2 + xyz - x^2 - xyz + x^2 - y^2} \\ &= \frac{ydx + xdy + dz}{0} \end{aligned}$$

$$ydx + xdy + dz = 0$$

$$d(xy) + dz = 0$$

$$V \equiv xy + z = b$$

∴ C.S. is $\phi(u, v) = 0$

$$\phi [x^2 + y^2 - z^2, xy + z]$$

70. Suppose the random variable X has distribution function $F(x) = \begin{cases} 0 & x \leq 0 \\ 1 - \exp(-x^2) & x > 0 \end{cases}$. What is the probability that X exceeds 1 ?

- A. e^{-2}
- B. e^{-1}
- C. e^{-3}
- D. e^{-4}

Ans. B

Sol. $P(x > 1)$ $F(x) = 1 - e^{-x^2}; x > 0$
 $= P(1 < x < \infty)$
 $= F(\infty) - F(1)$
 $= 1 - [1 - e^{-1}]$
 $= e^{-1}$

71. A total of 28 percent of American males smoke cigarettes, 7 percent smoke cigars, and 5 percent smoke both cigars and cigarettes. What percentage of males smoke neither cigars nor cigarettes?

- A. 30 percent
- B. 20 percent
- C. 80 percent
- D. 70 percent

Ans. D

Sol. Cigarettes → 28%
 Cigar → 7%
 Cigar & cigarettes → 5%

$$P(A \cup B) = P(A) + P(B) - P(A \cap B)$$

$$= 0.28 + 0.07 - 0.05 = 0.30$$

$$\overline{P(A \cup B)} = 1 - P(A \cup B)$$

$$= 1 - 0.3 = 0.7$$

72. If the average number of claims handled daily by an insurance company is 5, what proportion of days have less than 3 claims? Assume that the number of claims on different days is independent.

- A. $\frac{37e^{-5}}{2}$
- B. $\frac{31e^{-5}}{2}$
- C. $\frac{35e^{-5}}{2}$
- D. $\frac{39e^{-5}}{2}$

Ans. A

Sol. $\lambda = 5$

$$P(x) = \frac{\lambda^x \cdot e^{-\lambda}}{x!}$$

$$p(x < 3) = p(x = 0) + p(x = 1) + p(x = 2)$$

$$= \frac{5^0 \cdot e^{-5}}{0!} + \frac{5^1 \cdot e^{-5}}{1!} + \frac{5^2 \cdot e^{-5}}{2!}$$

$$= e^{-5} \left(1 + 5 + \frac{25}{2} \right)$$

$$p(x < 3) = \frac{37e^{-5}}{2}$$

73. A negative feedback system has a forward path gain of 18 and a feedback path gain of 0.15. What is the overall gain of the system?

- A. 4.86
- B. 10.66
- C. 3.26
- D. 2.86

Ans. A

Sol. $G = 18$

$H = 0.15$

$$\text{gain} = \frac{9}{1 + 94} = \frac{18}{1 + (18 \times 0.15)} = 4.86$$

74. Consider the following conditions for a second order system when subject to a unit step input:

- 1. With critical damping, there are no oscillations.
- 2. With no damping, the system output in oscillates amplitude.
- 3. With overdamping, the output takes longer time to reach the steady-state value.

Which of the above conditions is/are not correct?

- A. 2 and 3 only
- B. 1 only
- C. 2 only
- D. 1 and 3 only

Ans. C

Sol. 1. $\xi = 1 \rightarrow$ critical damping : no. oscillation

2. $\xi = 0 \rightarrow$ No. damping : oscillations

3. $\xi > 1 \rightarrow$ Over damped : No. oscillations

75. In Nyquist stability criterion, the closed-loop systems whose open-loop frequency response $G(j\omega) H(j\omega)$ loci, as ω goes from 0 to ∞ , do not encircle the -1 point, will be

- A. unstable
- B. marginally stable
- C. marginally unstable
- D. stable

Ans. *

Sol. Given $N = 0$

means $P - z = 0$ (or) $z - P = 0$ (based on contour)

can't conclude based on given in formation

76. Which error-time graph is relevant to the following integral mode controller output?

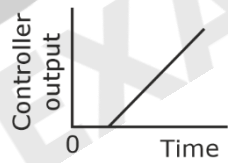

A.

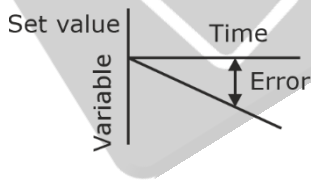

B.

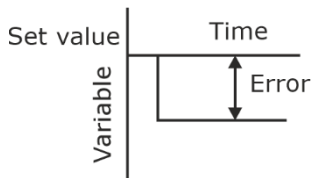

C.

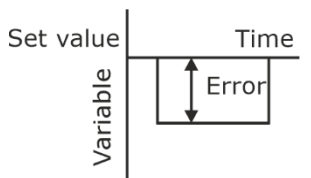

D.

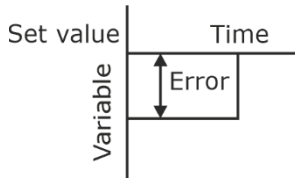

Ans. C

Sol. Controller output $u(t) = \int \text{error}$
 $u(t) = \int e(t)dt$

\therefore error-time graph will be =

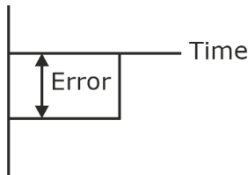

As Area keep on increasing as we goes with time

77. For the given transfer function, $G(s) = K(1 + Ts)$, what is the phase of frequency response?

- A. $\arctan(-\omega T)$
- B. $\arctan(-\omega T/2)$
- C. $\arctan(-2\omega T)$
- D. $\arctan(\omega T)$

Ans. A

Sol. $G(s) = \frac{K}{1 + Ts} = \frac{K}{1 + j\omega T}$

phase = $-\tan^{-1}(\omega T)$

78. Which one of the following steps is correct while plotting an open-loop bode diagram ?

- A. Transfer an open-loop TF into a constant frequency form.
- B. For the low-frequency asymptote, if there is only the proportion link, one should plot a horizontal line with the amplitude value $-20 \log K$ (dB).
- C. For the high-frequency asymptote, one should change the slope of the asymptote in every break frequency ωT for every link.
- D. Compensate the asymptote to get the precise constant time characteristic diagram.

Ans. C

Sol. At every corner frequency, the slope of the asymptote will change

79. For the closed-loop transfer function as part of necessary conditions for the stability of linear feedback system, the characteristic roots must satisfy the following conditions :

1. No nil solution
 2. No conjugate pure complex roots
 3. All the real roots must be negative
- Which of the above conditions are correct?

- A. 1 and 2 only
- B. 2 and 3 only
- C. 1 and 3 only
- D. 1, 2 and 3

Ans. C

Sol. 1. If there are roots at origin, it may be unstable or marginally stable, so there should be will solution

2. If conjugate complex roots on left then system may be stable. so and option is not correct

3. All roots (real) must be negative

80. The Routh array of an open-loop transfer function of unit negative feedback control system is as under :

S^3	1	12
S^2	6	$8(1 + k)$
S^1	$(32-4k)/3$	0
S^0	$8(1 + k)$	0

The system is stable and unstable when the values of 'k' respectively are

- A. 15 and 6
- B. 6 and 12
- C. 12 and 6
- D. 6 and 15

Ans. B

Sol. For stability, $\frac{32 - 4k}{3} > 0$

$$32 > 4K$$

$$K < 8$$

$$\text{and } 1 + K > 0$$

$$K > -1$$

For stability: $-1 < K < 8$

So, we can choose $K = 6$

and $K > 8 \Rightarrow K = 12$ unstable.

81. Consider the following table wherein three typical acceleration input signals are fed to various system types where 'R' represents the amplitude of the input (note the situation of acceleration input) and 'K' is the open-loop gain of the time constant type. What are the steady-state errors in place of A, B and C respectively in the table?

System type	Typing input signal		
	Step	Ramp	Acceleration
	$X(t)=R$	$X(t) = Rt$	$x(t) = \frac{R}{2} t^2$
0	$\frac{R}{1+K}$	∞	A
I	0	B	∞
II	C	0	R/K

- A. $\infty, R/K$ and 0
- B. $\infty, R/1+K$ and 0
- C. $\infty, R/K$ and ∞
- D. 0, $R/1+K$ and ∞

Ans. A

Sol. for type zero system

Acceleration constant $k_a = 0$

$$\text{Steady state error } e_{ss} = \frac{R}{k_a} = \frac{R}{0} = \infty$$

$$A = \infty$$

For type 1 system

$$\text{Ramp constant } K_v = \lim_{s \rightarrow 0} s G(s) = k$$

Steady state error $e_{ss} = \frac{R}{k_x} = \frac{R}{k}$

For type-2 system

Position constant $K_p = \infty$

Steady state error $e_{ss} = \frac{R}{K_p} = 0$

- 82.** Which one of the following is not a method to reduce steady-state error of a system ?
- A. Increase open-loop gain
 - B. Limiting system types
 - C. Feed forward control
 - D. Compound control

Ans. B

Sol. Limiting system types means not allowing time to increase, as we know time increases we can reduce error. so, option B suits

- 83.** Consider the following statements related to root locus :
1. The number of branches of the root locus equals the number of closed-loop poles.
 2. The root locus is symmetrical about the real axis.
 3. The root locus approaches straight lines as asymptotes as the locus approaches infinity.
- Which of the above statements are correct?
- A. 1 and 2 only
 - B. 2 and 3 only
 - C. 1 and 3 only
 - D. 1, 2 and 3

Ans. B

Sol. 1. The number of branches of the root locus equals the number of open-loop poles.
 2. The root locus is symmetrical about the real axis.
 3. The root locus approaches straight lines as asymptotes as the locus approaches infinity.

- 84.** Consider the following visualizing lead compensation representation frequency versus gain crossover frequency:

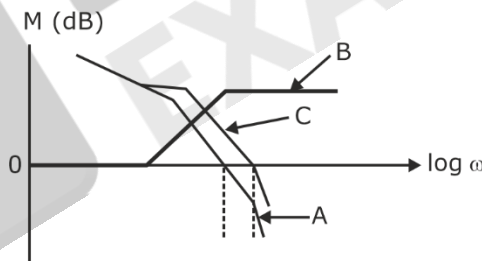

Which of the above curves is/are a compensator?

- A. A only
- B. B only
- C. C only
- D. Both A and B

Ans. B

Sol. Lead compensator

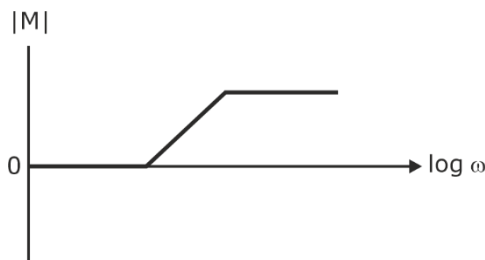

- 85.** Isolating transformers are commonly used in many types of electric circuits for the purpose of
- A. blocking alternating current signal between the circuits
 - B. blocking alternating current signals while maintaining direct current continuity between the circuits
 - C. blocking direct current signals while maintaining alternating current continuity between the circuits
 - D. blocking direct current signal between the circuits

Ans. C

Sol. blocking direct current signals while maintaining alternating current continuity between the circuits

- 86.** When there is no ferromagnetic material but only air present in between the coils, such a transformer is called
- A. Iron-core type transformer
 - B. Steel-core type transformer
 - C. Wet type transformer
 - D. Dry type transformer

Ans. D

Sol. When there is no ferromagnetic material but only air present in between the coils, such a transformer is called "dry type transformer".

- 87.** The objectionable audible humming sound in the core of the transformer due to magnetostriction is minimized by
- A. decreasing flux density
 - B. increasing flux density
 - C. use of stacking laminations
 - D. use of silicon-steel sheets

Ans. A

Sol. The objectionable audible humming sound in the core of the transformer: due to magnetostriction is minimized by decreasing flux density

- 88.** The ideal two-winding transformer primary and secondary windings has $N_1 = 100$ turns and $N_2 = 200$ turns with a mutual coupling flux described by the parabolic function $\phi_m(t) = -0.05(t^2 - 2t)$ Wb. The primary terminal voltage is
- A. $10(t - 1)$ Volts
 - B. $-10(t - 1)$ Volts
 - C. $20(t - 1)$ Volts
 - D. $-20(t - 1)$ Volts

Ans. A

Sol. $\phi_m = -0.05[t^2 - 2t]$

$$E = -N_1 \frac{d\phi_m}{dt} \text{ (Primary terminal Voltage)}$$

$$= -100[-0.05(2t - 2)]$$

$$E(t) = 10(t - 1)$$

- 89.** A 345-kV transmission line feeds a distribution substation that in turn has radial feeds to a 4160/2400-V, four-wire distribution network and the turns ratio of the Δ -Y connected 100-MVA transformer in this substation. Its line current (I_{L1}) at Δ side is
- A. 167.35 A
 - B. 96.62 A
 - C. 58.97 A
 - D. 138.79 A

Ans. A

Sol. Line current on delta side

$$S = \sqrt{3} V_L I_L$$

$$I_L = \frac{S}{\sqrt{3} \times V_L} = \frac{100 \times 10^6}{\sqrt{3} \times 345 \times 10^3}$$

$$I_L = 167.347A$$

90. A four-pole lap-wound DC machine armature has 54 slots with single-turn coils. How many armature conductors are required if there are two coil sides per slot?

- A. 27
- B. 54
- C. 81
- D. 108

Ans. D

Sol. $p=4, a=4$

no of slots =54

Since two coil per side is given. So total no of conductor = $2(54) = 108$

91. The magnetic cores of large transformers are built in stepped cores to

- A. minimize the hysteresis loss
- B. minimize the magnetizing loss
- C. minimize the use of copper and decrease copper loss
- D. minimize the eddy current loss

Ans. C

Sol. Minimize the use of copper and decrease copper loss

92. An autotransformer has an advantage over the equivalent two-winding transformer, which is

- A. no electrical isolation.
- B. greater short-circuit current
- C. higher excitation current
- D. lower leakage reactance

Ans. D

Sol. lower leakage reactance

93. The stator and rotor slots of an asynchronous motor are designed to traverse the axial length of the magnetic core at an angle from the true axial direction. The average value of the mmf wave over the axial length of the magnetic core is

- A. step transition
- B. ramped transition
- C. steep transition
- D. triangular transition

Ans. D

Sol. *

94. A 4-pole, 50-Hz, three-phase asynchronous motor is operating at a shaft speed of 1750 rpm. What is the speed of the stator air gap mmf wave?

- A. 188.49 rad/sec
- B. 157.07 rad/sec
- C. 127.23 rad/sec
- D. 87.64 rad/sec

Ans. B

Sol. $P = 4, F = 50\text{Hz}$

$$N_s = \frac{120f}{p} = \frac{120 \times 50}{4} = 1500\text{rpm}$$

$$\omega = \frac{2\pi N_s}{60} = \frac{2\pi}{60} \times 1500$$

$$\omega = 157.07\text{rad / sec}$$

95. Prior to placing a three-phase, Y-connected synchronous generator in service on the Y-connected electric utility grid, three lamps are connected across the open contactors served as indicators to assure synchronization conditions if the lamps will blink OFF and ON which indicates

- A. the voltage magnitudes of the oncoming synchronous generator and the electric utility are not matched
- B. the frequency of the oncoming synchronous generator and the electric utility are not equal
- C. the phase sequence of the oncoming synchronous generator and the electric utility are not matched
- D. the voltage magnitudes, frequency and phase sequence of the oncoming synchronous generator and the electric utility are matched

Ans. B

Sol. The frequency of the oncoming synchronous generator and the electric utility are not equal.

96. A primitive stepper motor and its digital driver circuit is furnished with a train of f pulses per second, that the input of the controller is divided so that the output is sent in sequence to one phase winding at a time with 2p as the number of phases and k number of teeth. Then the rotor angular motion per pulse is a step of

- A. π/p radians
- B. P/π radians
- C. $\pi/k2p$ radians
- D. π/kp radians

Ans. D

Sol. No of phases = 2p

K = No of teeth

The rotor angular motion per pulse = $\frac{360}{mp}$, m = no of phases

= $\frac{360}{mk}$, p = no. of teeth = k

m = 2p

= $\frac{360}{2pk}$

= $\frac{180}{pk} = \frac{\pi}{kp}$

97. Which one of the following statements is not correct?

- A. The corona loss on the middle conductor is more as compared with the two outer conductors.
- B. The corona loss is less in hilly areas than in plain areas.
- C. The rains increase the corona loss in transmission lines.
- D. The height of the conductors from the ground has its effect on corona loss.

Ans. B

Sol. Effects of corona loss:

1. Corona effect is more prevalent in the middle conductor in a flat conductor configuration
2. Transmission lines passing through a hilly area may have higher corona loss than that of similar transmission lines in the plains because in a hilly area the density of air is low.
3. In stormy weather conditions, dusty and rainy conditions, the number of free electrons and ions are more than that in fair weather condition. Hence the disruptive voltage reduces under adverse weather condition. This in turn increases the corona loss considerably

98. For economic size the ratio of outer diameter to the conductor diameter should be 'e'. What is the economic overall diameter of a 1-core cable metal sheathed for a working voltage of 85 kV if the dielectric strength of the insulating material is 65 kV/cm ?

- A. 1.6e cm
- B. 2.6e cm
- C. 3.6e cm
- D. 4.6e cm

Ans. B

Sol. $E = \frac{V_{ph}}{r \ln \frac{R}{r}} \Rightarrow E = \frac{V_{ph}}{r}$

$r = \frac{85}{65} = 1.3 \text{ cm}$

as $\frac{R}{r} = e \Rightarrow R = 1.3e$

$D = 2.6e$

99. When impedance is being calculated for an alternator, which measurement of parameter requires the series connection of windings in stator windings?

- A. Positive sequence impedance
- B. Negative sequence impedance
- C. Zero sequence impedance
- D. Sub-transient reactance

Ans. C

Sol. Series connection is possible only if currents are same, it is possible with zero sequence impedance.

100. What is the percentage increase of busbar voltage required to compensate for the reactance drop when the feeder having a reactance of 5 % carries a full load current at a p.f. 0.8 lagging?

- A. 3%
- B. 4%
- C. 1.5%
- D. 2%

Ans. A

Sol. For series impedance,

% voltage drop = (% reactance voltage drop) x sin φ
 = 5 x sin[sin⁻¹0.8] = 3%

101. The overcurrent relays are categorized by obtaining their characteristics are under:

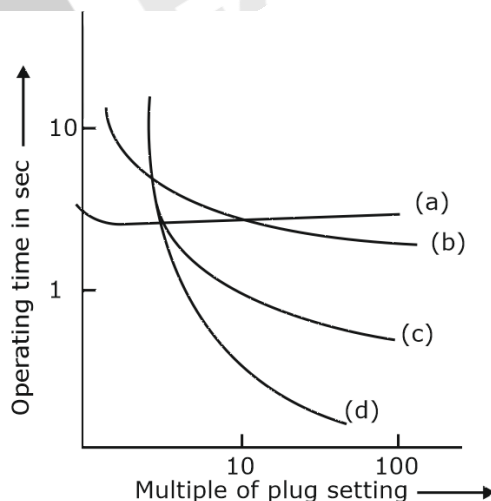

The curve B in the characteristics is pertaining to which category of current relay?

- A. Extremely to which
- B. very inverse relay
- C. Inverse time
- D. Inverse definite minimum time

Ans. D

- Sol.** Curve A → definite time relay
 Curve B → IDMT
 Curve C → very inverse relay
 Curve D → External inverse relay

102. Consider the following statements:

1. The arcing time of arc controlled circuit breaker varies considerably depending upon the breaking current.
2. Except for a certain medium range of voltages, air circuit breakers are widely used for the low voltage circuits as well as the highest transmission voltage.
3. The resistance switching reduces help to distribute the transient recovery voltage more uniformly across the several gaps.
4. With the use of better insulating materials for the arcing chambers, the oil CBs are able to meet the increased fault levels of the systems easily.
5. The resistance switching reduces transient voltages during switching out inductive load but enhances for capacitive loads.

Which of the above statements is/are *not* correct ?

- A. 1 and 2 only B. 2 and 3. only
 C. 4 only D.5 only

Ans. B

Sol. These two statement are false

1. Except for a certain medium range of voltages, air circuit breakers are widely used for the low voltage circuits as well as the highest transmission voltage.
2. The resistance switching reduces help to distribute the transient recovery voltage more uniformly across the several gaps.

103. Consider the table below for different types of buses where each set may consist of any parameters 'V' is voltage magnitude, 'P' is real power inject, 'Q' is reactive power and 'δ' is phase angle.

Bus type	Set of quantities to be specified for bus	Set of quantities to be obtained
Load bus	Set A	Set D
Slack bus	Set B	Set E
Generator bus	Set C	Set F

Select the correct answer using the above table:

- A. Set A and E are same, but Set C and D are different
- B. Set B and F are same, but set C and E are different
- C. Set C and D are same, but Set A and F are different
- D. Set C and E are same, but Set D and B are different

Ans. C

Sol.

Bus type	Specified	Unspecified
Load bus	P, Q	V, δ
Generator bus	P, V	Q, δ
Slack bus	V, δ	P, Q

104. While the load flow equations are nonlinear and they are solved by using Gauss-Seidel Iterative Method by including PV buses, what would be the reason for the violation of reactive power limit?

- A. Too low specified voltage level only
- B. Too high specified voltage level only
- C. Either too low or too high specified voltage level
- D. Neither too low nor too high specified voltage level

Ans. C

Sol. The violation of reactive power limit could be due to the specified voltage either being too low or too high. Since input voltage specified can be obtained only by controlling reactive power, therefore, it is possible that we have specified voltage beyond the capability of the reactive power generation of the generator

105. Consider a system consisting of a synchronous machine connected to an infinite bus bar. The below power angle curve is obtained using equal area criterion when sudden increase in mechanical load on that motor occurs :

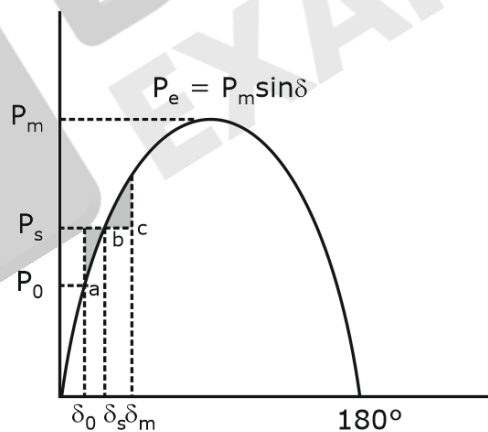

- A. $P_e = P_s$
- B. $P_e < P_s$
- C. $P_e > P_s$
- D. $P_m = P_s$

Ans. A

Sol. At point 'a'

$P_o = P_e$ (initially) and $\omega = \omega_s$

Now, motor output is increased, $P_{out} > P_e$, so rotor starts accelerating. The moment it reaches point 'b', it won't stop due to inertia of rotor at goes till point 'c'. After point 'c' it will come back

again to point 'b' and goes towards point 'a' because of inertia. This swinging will happen until equilibrium condition at point 'b' i.e., $P_s = P_e$.

106. If T_s represents the shaft torque and T_e the electromagnetic torque and if these are assumed positive for a generator, the net torque causing acceleration T_a is

- A. $T_a = T_s - T_e$
- B. $T_a = T_s + T_e$
- C. $T_a = 2T_s - T_e$
- D. $T_a = T_s + 2T_e$

Ans. A

Sol. For generator case, net torque is $T_{net} = T_s - T_e$

T_s : shaft torque

T_e : Electromagnetic torque

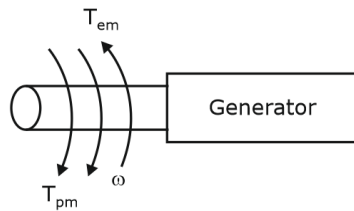

107. Consider the following conditions :

In HVDC transmission, high power factor of the system is maintained for the following reason(s):

1. For a given current and voltage of the thyristor and transformers, the power rating of the converters is equal.
2. The stresses on the thyristors and damping circuits are reduced.
3. For the same power to be transmitted the current rating of the system is reduced and also the copper losses in the ac lines are reduced.

Which of the above conditions is/are correct?

- A. 1 only
- B. 2 only
- C. 3 only
- D. 2 and 3 only

Ans. D

Sol. In case of HVDC transmission it is desirable to have a high power factor of the system for the following reasons:

- (i) For a given current and voltage of the thyristor and transformers, the power rating of the converters is high.
- (ii) The stresses on the thyristors and damping circuits is reduced.
- (iii) For the same power to be transmitted the current rating of the system is reduced and also the copper losses in the a.c. lines are reduced.
- (iv) In a.c. lines the voltage drop is reduced.

108. Which type of hydro turbine is totally embedded in the fluid and powered from the pressure drop across the device?

- A. Impulse turbine only
- B. Reaction turbine only
- C. Squirrel cage turbine only
- D. Both impulse turbine and reaction turbine

Ans. A

Sol. Impulse turbine is embedded in the fluid and powered from the pressure drop across the device

109. By considering the standard notations, reverse recovery time (t_{rr}) of a power diode is

A. $t_{rr} = \sqrt{\frac{2Q_R}{di/dt}}$

B. $t_{rr} = \sqrt{\frac{2Q_R}{dv/dt}}$

C. $t_{rr} = \sqrt{\frac{2dv/dt}{Q_R}}$

D. $t_{rr} = \sqrt{\frac{2dI/dt}{Q_R}}$

Ans. A

Sol. Reverse recovery charge

$$Q = \frac{1}{2} I_{rr} t_{rr}$$

$$Q_{rr} = \frac{1}{2} \frac{di}{dt} t_{rr}^2$$

$$t_{rr} = \sqrt{\frac{2Q_{rr}}{\frac{di}{dt}}}$$

110. The overdrive factor (ODF) of a power transistor can be expressed as

- A. base current required to operate in saturation (I_{BS})/base current (I_B)
- B. base current (I_B)/base current required to operate in saturation (I_{BS})
- C. base current required to operate in saturation (I_{BS})/ collector current (I_C)
- D. collector current (I_C)/ base current (I_B)

Ans. B

Sol. Overdrive factor of power transistor is how far into saturation a transistor is driven

$$= \frac{\text{Base current } (I_B)}{\text{Base current required to operate in saturation } (I_{BS})}$$

111. When the amplitude of the gate pulse to thyristor is increased,

- A. the delay time would decrease, but the rise time would increase.
- B. both delay time and rise time would increase.
- C. the delay time would decrease, but the rise time remains unaffected.
- D. the delay time would increase, but the rise time would decrease.

Ans. C

Sol. By increasing gate pulse amplitude, delay time decrease and rise time remains unaffected

112. A single-phase full-wave bridge rectifier circuit is fed from a 220 v, 50 Hz supply. It consists of four diodes, a load resistance 20 Ω and a very large inductance so that the load current is constant. What is the average or dc output voltage?

- A. 78.135 V
- B. 140.125 V
- C. 198.165 V
- D. 311.025 V

Ans. C

Sol. $V_0 = \frac{2V_m}{\pi} = \frac{2 \times 220\sqrt{2}}{\pi} = 198.069$

- 113.** In a single-phase full-wave controlled bridge rectifier with source inductance and R-L load, the output voltage during overlap is equal to
- A. source voltage
 - B. difference of source voltage and voltage drop in inductance
 - C. zero
 - D. addition of source voltage and voltage drop in inductance

Ans. C

Sol. During overlap (due to source inductance), all the diodes will be shorted and output voltage will be zero.

- 114.** If a step-down chopper operates in the continuous conduction mode with a duty cycle D, the ripple factor is

- A. $\frac{\sqrt{D - D^2}}{D}$
- B. $\frac{\sqrt{D^2 + D}}{D}$
- C. $\frac{D}{\sqrt{D^2 - D}}$
- D. $\frac{D}{\sqrt{D + D^2}}$

Ans. A

Sol. Step down chopper.

Average $\Rightarrow V_0 = DV_{dc}$

Ripple factor = $\sqrt{(FF)^2 - 1}$

= $\sqrt{\left(\frac{RMS}{Avg}\right)^2 - 1} = \sqrt{\frac{D}{D^2} - 1}$

= $\sqrt{\frac{D - D^2}{D}}$

- 115.** When a separately excited dc motor is to be controlled from a 3-phase source for operation in the first quadrant only, which one of the following converters is used?
- A. Three-phase dual converter
 - B. Three-phase semi converter
 - C. Three-phase full converter
 - D. Three-phase half-wave converter

Ans. B

Sol. In case of three phase semi converter, both voltage and current are positive means operated in 1st quadrant.

- 116.** A wound rotor or slip-ring asynchronous motor is commonly used as drive in overhead cranes and load equalization. Which of the following speed controls is adopted ?
- A. Stator current control
 - B. Static rotor resistance control
 - C. Stator voltage control
 - D. Stator voltage and frequency control

Ans. C

Sol. In overhead cranes and load equalization, stator voltage control is used

117. Which one of the following statements is correct in a series resonant converter ?

- A. The load current is a square waveform.
- B. The output voltage waveform depends on the damping factor of load impedance.
- C. The trigger frequency is higher than the damped resonant frequency.
- D. The output voltage waveform does not depend on the damping factor of load impedance.

Ans. B

Sol. In series resonant converter, the load seen as a RLC load. So damping factor decide output voltage waveform

118. Which of the following switching techniques is commonly opted in resonant converters ?

- A. Frequency switching
- B. Voltage switching
- C. Zero voltage switching or zero current switching
- D. Current switching

Ans. C

Sol. General switching techniques used in resonant converters is ZCS are ZVS switching.

119. The function of static transfer switch in a multi modular Uninterruptible Power Supply (UPS) system is to change over

- A. the power supply to the critical load from the UPS to power line
- B. the battery bank to the critical load
- C. the power supply to UPS
- D. the battery bank to the UPS from the power line

Ans. A

Sol. Function of static transfer switch in UPS is power supply to the critical load from the UPS to power line

120. Static VAR Compensator (SVC) is usually designed to operate at

- A. slightly lagging power factor
- B. leading power factor
- C. unity power factor
- D. zero power factor lagging

Ans. B

Sol. Static VAR compensator operate at leading power factor so that it supplies lagging reactive power as load demands it.

121. What is the spectral efficiency of 16-QAM

- A. 1 bps/Hz
- B. 2 bps/Hz
- C. 3 bps/Hz
- D. 4 bps/Hz

Ans. B

Sol. Spectral efficiency = $\frac{\text{Bit rate}}{\text{Bandwidth}}$

Bandwidth for M-aryQAM,

$$BW = \frac{2R_b}{\log_2 M}$$

$$\text{Spectral efficiency} = \frac{R_b}{\frac{2R_b}{\log_2 M}} = \frac{\log_2 M}{2}$$

$$= \frac{\log_2 16}{2} = 2 \text{ bps / Hz}$$

$$= \frac{\log_2 16}{2} = 2 \text{ bps / Hz}$$

Option B is correct.

122. A continuous-time signal is given below:

$$X(t) = 8 \cos 200\pi t$$

What is the minimum sampling rate required to avoid aliasing

- A. 100 Hz
- B. 200 Hz
- C. 50 Hz
- D. 150 Hz

Ans. B

Sol. $f_{\max} = 100 \text{ Hz}$

$$\begin{aligned} \text{Nyquist rate} &= f_{\text{sampling}} = 2 f_{\max} \\ &= 2(100) = 200 \text{ Hz.} \end{aligned}$$

123. By considering the standard notations, in DACs, a glitch due to the switch associated with the most significant bit can have an amplitude almost equal to

- A. $2V_{\text{ref}}$
- B. $\frac{1}{2} V_{\text{ref}}$
- C. $3V_{\text{ref}}$
- D. $\frac{1}{3} V_{\text{ref}}$

Ans. B

Sol. $V_{\text{MSB}} = V_{\text{R}}/2$

This is a standard result.

124. What is the value of Q factor if the band pass filter is having frequencies from 800 Hz to 1200 Hz ?

- A. 1.30
- B. 2.45
- C. 3.40
- D. 4.35

Ans. B

Sol. B.W = 1200 - 800

$$\text{B.W} = 400 \text{ Hz}$$

$$\text{Resonance frequency, } f_r = \sqrt{1200 \times 800}$$

$$= 979.8 \text{ Hz}$$

$$Q = \frac{f_r}{\text{BW}}$$

$$= \frac{979.8}{400}$$

$$= 2.45 \text{ Hz}$$

125. An AM broadcast radio transfer radiates 10 k Watts of power if modulation percentage is 60 .
What is the carrier power?

- A. 6.25 kW
- B. 8.47 kW
- C. 13.60 kW
- D. 10.00 kW

Ans. B

Sol. $P_t = P_c \left(1 + \frac{m_a^2}{2} \right)$

$$P_c = \frac{P_t}{1 + \frac{m_a^2}{2}} = \frac{10}{1 + \frac{(0.6)^2}{2}} = 8.47 \text{ kW}$$

126. A PLL FM detector uses a VCO with $k_f = 100 \text{ kHz/V}$. If it receives an FM signal with a deviation of 75 kHz and sine-wave modulation , what is the RMS output voltage from the detector?

- A. 3.57 V
- B. 2.54 V
- C. 1.55
- D. 0.53

Ans. *

Sol. *

127. The signal power and noise power measured at the input of an amplifier are 150 μW and 1.5 μW respectively. If the signal power at the output 1.5 W and noise power is 40 mW, what is the amplifier noise factor?

- A. 2.666
- B. 2.750
- C. 4.266
- D. 5.625

Ans. A

Sol. Noise factor = $\frac{S_i / N_i}{S_o / N_o}$

$$= \frac{150}{1.5} \times \frac{40 \times 10^{-3}}{1.5}$$

$$= 2.666$$

128. A discrete source emits one of five symbols once every millisecond with probabilities

$\frac{1}{2}, \frac{1}{4}, \frac{1}{8},$ and $\frac{1}{16}$. What is the source entropy?

- A. 0.875 bits/symbol
- B. 1.875 bits/symbol
- C. 2.875 bits/symbol
- D. 3.875 bits/symbol

Ans. B

Sol. Source entropy (H) = $\sum_{i=1}^m P_i \log_2 \left(\frac{1}{P_i} \right)$

$$= \frac{1}{2} \log_2^2 + \frac{1}{4} \log_2^4 + \frac{1}{8} \log_2^8 + 2 \times \frac{1}{16} \log_2^{16}$$

$$= 1.875 \text{ bits/symbol}$$

129. According to the description of, the AND instruction of 8086 microprocessor, what are the essential conditions to be satisfied while executing it?

- 1. The source can be a register or a memory location.
- 2. The destination can be a register or a memory location.
- 3. The source and destination must both be bytes or be words.
- 4. The source and the destination cannot both be memory locations in an instruction

- A. 1 and 2 only
- B. 1 and 4 only
- C. 1,2,3 and 4
- D. 1,2 and 3 only

Ans. C

Sol. The essential conditions to be satisfied while executing AND instruction are:

The source can be a register or a memory location.

The destination can be a register or a memory location.

The source and destination must both be bytes or be words.

The source and the destination cannot both be memory locations in an instruction.

130. What is the modulation index, if the $E_{max} = 150$ mV and $E_{min} = 70$ mV?

- A. 40%
- B. 30%
- C. 36.4%
- D. 44.6%

Ans. C

Sol. Modulation index (ma) = $\frac{E_{max} - E_{min}}{E_{max} + E_{min}}$

$$= \frac{150 - 70}{150 + 70} = 0.364$$

$$= 36.4\%$$

131. A receiver has a noise power bandwidth of 12 kHz. A resistor which matches with the receiver input impedance is connected across the antenna terminals. What is the noise power contributed by this resistor in the receiver bandwidth?

(Take temperature as 30°C)

- A. 2.581×10^{-17} W
- B. 3.181×10^{-17} W
- C. 4.636×10^{-17} W
- D. 5.017×10^{-17} W

Ans. D

Sol. Noise power contributed by this resistor in the receiver bandwidth given by,

$$P_N = kT_N B$$

$$= 1.38 \times 10^{-23} \times (273 + 30) \times 12 \times 10^3$$

$$= 5.017 \times 10^{-17}$$

132. An amplifier has a bandwidth of 4 MHz with 10 kΩ as the input resistor. What is the rms noise voltage at the input to this amplifier if the room temperature is 25°C?

- A. 35.23 μV
- B. 40.55 μV
- C. 25.65 μV
- D. 14.62 μV

Ans. C

Sol. rms noise voltage,

$$V_n = \sqrt{4KTBR}$$

$$V_n = \sqrt{4 \times 1.38 \times 10^{-23} \times 298 \times 4 \times 10^6 \times 10 \times 10^3}$$

$$V_n = 25.65 \mu\text{V}$$

133. How many numbers of multiplications is needed in the calculation of FFT with 64 point sequence?

- A. 160
- B. 172
- C. 192
- D. 200

Ans. C

Sol. $\frac{N}{2} \log_2 N = \text{No of multiplication}$

$$\text{No. of multiplication} = \frac{64}{2} \log_2 64$$

$$= 32 \log_2 2^6$$

$$= 32 \times 6 \times \log_2 2$$

$$= 192$$

134. Which one of the following is the correct Butterworth polynomial for second order filter?

- A. $s^2 + s + 1$
- B. $s^2 + \sqrt{2}s + 1$
- C. $s^2 + 2s + 1$
- D. $s^2 + s + 2$

Ans. B

Sol. LPF and HPF analog butter worth filter transfer function

S. No	Order of the filter	Low Pass filter	High Pass filter
1.	1.	$1/s + 1$	$s/s + 1$
2.	2.	$1 / s^2 + \sqrt{2}s + 1$	$s^2 / s^2 + \sqrt{2}s + 1$
3.	3.	$1/s^3 + 2s^2 + 2s + 1$	$s^3/s^3 + 2s^2 + 2s + 1$

135. Which one of the following is the correct relation of mapping from the 's-plane' to the 'z-plane' in bilinear transformation ?

$$A. s = \frac{2}{T} \left[\frac{1+z^{-1}}{1-z^{-1}} \right]$$

$$B. s = \frac{T}{2} \left[\frac{1-z^{-1}}{1+z^{-1}} \right]$$

$$C. s = \frac{T}{2} \left[\frac{1+z^{-1}}{1-z^{-1}} \right]$$

$$D. s = \frac{2}{T} \left[\frac{1-z^{-1}}{1+z^{-1}} \right]$$

Ans. A

Sol. From s to z bilinear formula

$$s = \frac{2}{T} \left[\frac{1-z^{-1}}{1+z^{-1}} \right]$$

136. The fundamental period of complex signal $x(t) = e^{j\omega_0 t}$ is

- A. $2\pi/\omega_0$
- B. π/ω_0
- C. $2\pi/\omega_0$
- D. π/ω_0

Ans. A

Sol. $T = \frac{2\pi}{\omega}$

from $x(t) = e^{j\omega_0 t}$

$\omega = \omega_0$

$T = \frac{2\pi}{\omega_0}$

137. The energy contained of the signal $x(t) = e^{-2t}u(t)$ is

- A. $\frac{1}{2}$
- B. 2
- C. $\frac{1}{4}$
- D. 4

Ans. C

Sol. $x(t) = e^{-2t}u(t)$

From $e^{-at} \rightarrow \text{Energy} = \frac{1}{2a}$

We can say that

$E = \frac{1}{2(2)} = \frac{1}{4}$ joules

138. Which one of the following is a useful property of the unit impulse signal $\delta(t)$?

- A. $\delta(at) = a\delta(t)$
- B. $\delta(at) = \delta(t)$
- C. $\delta(at) = |\delta(t)|^{-a}$
- D. $\delta(at) = \frac{1}{|a|}\delta(t)$

Ans. D

Sol. From basic property of impulse

We can say that

$\delta(at) = \frac{1}{|a|}\delta(t)$

139. Which one of the following is correct for the system represented by the relation $y(t) = x(\sin(t))$, where, $x(t)$ and $y(t)$ are input and output respectively?

- A. It is causal and linear.
- B. It is non-causal and linear.
- C. It is causal and non-linear.
- D. It is non-causal and non-linear.

Ans. A

Sol. Given $y(t) = x(\sin(t))$

1. consider some values for t

At $t = -\pi$

$$y(n) = 0$$

For present value $-n$, $x(t)$ gives future value $x(0)$, so the system is causal.

2. Let's say

$$y_1(t) = x_1(\text{sint})$$

$$y_2(t) = x_2(\text{sint})$$

$$y_1(t) + y_2(t) = x_1(\text{sint}) + x_2(\text{sint}) \quad \dots(1)$$

Similarly, keep $x(t) = x_1(\text{sint}) + x_2(\text{sint})$ directly,

$$y(t) = x_1(\text{sint}) + x_2(\text{sint}) \quad \dots(2)$$

(1) = (2) \rightarrow system is linear

140. The Fourier series representations are based on using

- A. constant coefficients
- B. cosine functions only
- C. sine functions only
- D. orthogonal functions

Ans. D

Sol. The Fourier series representation are based on using orthogonal functions.

141. What is the Fourier transform of rectangular pulse as shown in the figure below?

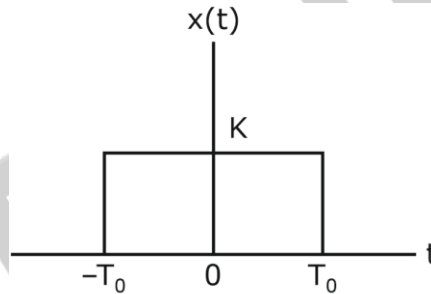

- A. $2KT_0 \text{sinc}\left(\frac{\omega T_0}{\pi}\right)$
- B. $2KT_0 \text{sinc}\left(\frac{\omega T_0}{2\pi}\right)$
- C. $KT_0 \text{sinc}\left(\frac{\omega T_0}{\pi}\right)$
- D. $KT_0 \text{sinc}\left(\frac{\omega T_0}{2\pi}\right)$

Ans. A

Sol.

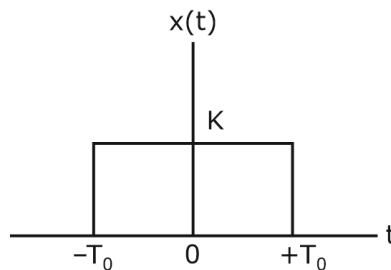

$$x(t) = K \text{rect}\left(\frac{t}{2T_0}\right)$$

$$K \text{rect}\left(\frac{t}{\tau}\right) \longleftrightarrow K\tau \text{sinc}\left(\frac{\omega\tau}{2\pi}\right)$$

$$K \operatorname{rect}\left(\frac{t}{2T_0}\right) \longleftrightarrow 2T_0 K \operatorname{sinc}\left(\frac{\omega(2T_0)}{2\pi}\right)$$

$$K \operatorname{rect}\left(\frac{t}{2T_0}\right) \longleftrightarrow 2T_0 K \operatorname{sinc}\left(\frac{\omega(2T_0)}{2\pi}\right)$$

142. What is the Fourier transform of the function $f(t) = te^{-|t|}$?

- A. $\frac{4\omega}{(1 + \omega^2)^2}$
- B. $\frac{-4\omega}{(1 + \omega^2)^2}$
- C. $\frac{4\omega}{(1 + \omega)^2}$
- D. $\frac{-4\omega}{(1 + \omega)^2}$

Ans. B

Sol. $te^{-|t|} \longleftrightarrow ?$

$$e^{-a|t|} \longleftrightarrow \frac{2a}{\omega^2 + a^2}$$

If $a = 1$

$$e^{-|t|} \longleftrightarrow \frac{2}{\omega^2 + 1}$$

from property, $tx(t) \longleftrightarrow j \frac{dx(\omega)}{d\omega}$

$$te^{-|t|} \longleftrightarrow j \frac{d}{d\omega} \left[\frac{2}{\omega^2 + 1} \right] = \frac{-4j\omega}{(\omega^2 + 1)^2}$$

143. What is the signal $x(t)$, based on the following facts;

1. $x(t)$ is periodic with period $T_0 = 4$ and has Fourier series coefficients $c[k]$.
2. $x(t)$ is real-valued
3. $c[k] = 0$ for $|k| > 1$.
4. The signal $y(t)$, whose Fourier series coefficients are $d[k] = e^{-jn k/2} c[k]$, is odd.
5. $\frac{1}{4} \int_{-2}^2 |x(t)|^2 dt = \frac{1}{2}$

- A. $(2)^m \cos(\omega_0 t)$
- B. $(-1)^m \cos(2\omega_0 t)$
- C. $(-2)^m \cos(2\omega_0 t)$
- D. $(-2)^m \cos(\omega_0/2t)$

Ans. B

Sol. (i) Option A and D represents aperiodic signals

(ii) Option C represents an even signal if it is delayed by $\frac{k\pi}{2}$

(iii) Option (B) i.e., $(-1)^m \cos(\omega_0 t)$

Satisfies all points 1 to 5

144. From the plot shown below, what are the necessary and sufficient conditions for a second order causal LTI discrete time system to be stable?

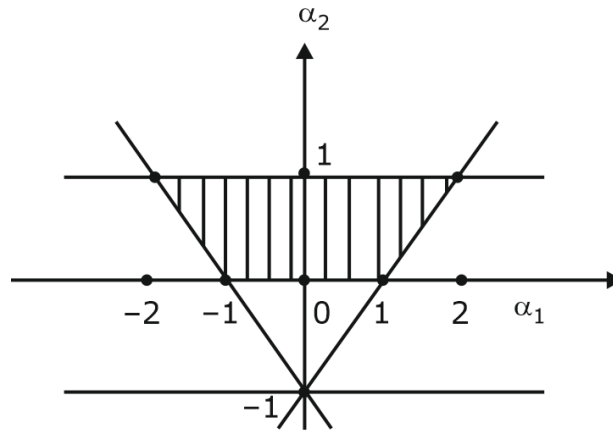

- A. $|a_1| < 1$ & $|a_2| < 1 + a_1$
- B. $|a_1| < 1$ & $|a_1| < 1 + a_2$
- C. $|a_1| > 1$ & $|a_2| > 1 + a_1$
- D. $|a_2| > 1$ & $|a_1| > 1 + a_2$

Ans. *

Sol.

Directions : Each of the next six (06) items consist of two statements, one labelled as the 'Statement (I)' and the other as 'Statement (II)'. You are to examine these two statements carefully and select the answers to these items using the codes given below :

Codes :

- A. Both Statement (I) and Statement (II) are individually true and Statement (II) is the correct explanation of Statement (I).
- B. Both Statement (I) and Statement (II) are individually true, but Statement (II) is not the correct explanation of Statement (I).
- C. Statement (I) is true, but Statement (II) is false.
- D. Statement (I) is false, but Statement (II) is true.

145. Statement (I):

Diodes designed expressly to operate in the forward biased region are called zener diodes.

Statement (II):

The principal operating region for a zener diode is negative in terms of both voltage and current.

Ans. D

Sol. Diodes designed expressly to operate in the reverse biased region are called zener diodes. So statement I is false.

Statement II is true. For a Zener diode, the VI graph has both current and voltage as negative.

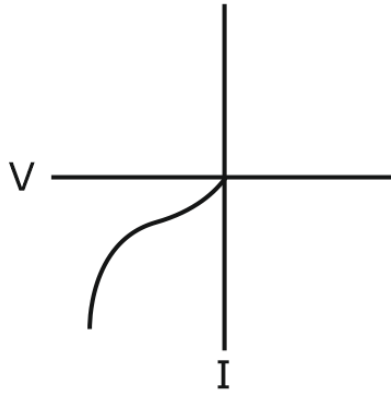

146. Statement (I):

A small-signal equivalent circuit of a BJT that applies to both n-p-n and p-n-p transistors is valid at lower frequencies by ignoring capacitance effects.

Statement (II) :

Despite the structural similarities, a p-n-p BJT has higher current gain than a comparable n-p-n BJT because holes are less mobile than electrons.

Ans. C

Sol. In small signal analysis of npn or pnp transistor, we won't consider the effect of junction capacitance at low frequency. And junction capacitance is considered only in high frequency model. So statement I is correct. Despite the structural similarities, a npn BJT has higher current gain than a comparable pnp BJT because the mobility of electrons is higher than that of holes. So statement II is wrong.

147. Statement (I) :

MOSFETs are preferred over JFETs for digital integrated circuits, either p-channel metal-oxide semiconductor or n-channel metal-oxide semiconductor logic circuits can be constructed.

Statement (II) :

The usage of a p-channel MOSFET as the active load for an n-channel MOSFET leads to a logic family known as complementary-symmetry MOS or CMOS.

Ans. B

Sol. Both the statements are true but statement 2 is not the correct explanation of statement-1

148. Statement (1) :

A system is LTI if and only if there exists a signal, called the system unit impulse response.

Statement (II) :

The output of a discrete-time LTI system is equal to the convolution sum between the input signal and its unit impulse response.

Ans. D

Sol. S-I is false

S-II is true

149. Statement (I) :

The root locus is the path of the roots of the characteristic equation traced out in the s-plane as a system parameter varies from zero to infinity

Statement (II) :

The frequency response of a system is defined as the steady-state response of the system to a non-sinusoidal unique input signal, and the resulting output signal for a linear system is sinusoidal in the steady-state; it differs from the input only in amplitude and phase angle.

Ans. C

Sol. The root locus is the path of the roots of the characteristic equation traced out in the s-plane as a system parameter varies from zero to infinity

For non-sinusoidal input output will not be sinusoidal

150. Statement (I) :

Transformers take advantage of the high magnetic energy density of ferromagnetic material to allow economical device design, however, the non-linear nature of ferromagnetic material leads to introduction of harmonics in current or voltage-

Statement (II) :

The non-linear nature of the transformer magnetizing inductance can lead to a transient inrush

Ans. B

Sol. *



Answer Key

Set-A

Q. No.	Answer	Q. No.	Answer	Q. No.	Answer	Q. No.	Answer
1.	D	26.	D	51.	B	76.	C
2.	C	27.	D	52.	A	77.	A
3.	B	28.	C	53.	A	78.	C
4.	D	29.	B	54.	A	79.	C
5.	C	30.	A	55.	C	80.	B
6.	D	31.	D	56.	C	81.	A
7.	D	32.	B	57.	B	82.	B
8.	B	33.	B	58.	D	83.	B
9.	D	34.	D	59.	A	84.	B
10.	C	35.	A	60.	D	85.	C
11.	B	36.	B	61.	*	86.	D
12.	C	37.	C	62.	D	87.	A
13.	C	38.	A	63.	B	88.	A
14.	C	39.	C	64.	B	89.	A
15.	A	40.	D	65.	A	90.	D
16.	C	41.	C	66.	B	91.	C
17.	D	42.	B	67.	C	92.	D
18.	D	43.	C	68.	D	93.	D
19.	D	44.	B	69.	A	94.	B
20.	C	45.	B	70.	B	95.	B
21.	B	46.	D	71.	B	96.	D
22.	A	47.	C	72.	A	97.	B
23.	B	48.	C	73.	A	98.	B
24.	D	49.	D	74.	C	99.	C
25.	A	50.	A	75.	*	100.	A

Q. No.	Answer	Q. No.	Answer
101.	D	126.	*
102.	B	127.	A
103.	C	128.	B
104.	C	129.	C
105.	A	130.	C
106.	A	131.	B
107.	D	132.	C
108.	A	133.	C
109.	A	134.	B
110.	B	135.	A
111.	C	136.	A
112.	C	137.	C
113.	D	138.	D
114.	C	139.	A
115.	B	140.	A
116.	C	141.	A
117.	B	142.	B
118.	C	143.	B
119.	A	144.	*
120.	D	145.	D
121.	B	146.	C
122.	B	147.	B
123.	A	148.	D
124.	C	149.	C
125.	B	150.	B

ESE EE Prelims Paper-2: Previous Year's Cut off

S. No.	Year	General	EWS	OBC	SC	ST
1.	2023	250	250	250	210	240
2.	2022	231	231	231	194	230
3.	2021	235	225	235	199	230
4.	2020	238	226	229	187	194
5.	2019	221	NA	211	191	172
6.	2018	230	NA	218	190	191
7.	2017	257	NA	241	210	208

Our Outstanding GATE Results



Rank 02
Poojasree (EC)



2021



Rank 03
Manoj (EC)



Rank 03
Munish (ME)



Rank 06
Parag (EC)



Rank 07
Vatsal (ME)



Rank 08
Rahul (CE)



Rank 08
Hemant (EE)



Rank 08
Rajat (ME)



Rank 09
Vamsi (EC)



Rank 13
Shashwat (CE)



Rank 06
Ghanendra (EC)



2020



Rank 09
Avinash (ME)



Rank 09
Himanshu (EE)



Rank 26
Kartikay (CE)



Rank 30
Raja (EC)



Rank 39
Akash Singh (CS)



Rank 39
Navneet (CS)



Rank 54
Rishi (EE)



Rank 56
Apurv Mittal (ME)



Rank 56
Nikhil (ME)

Our Outstanding GATE Results

80+

Students under
AIR-100

2022



Rank 01
Ram (EC)



Rank 02
Amit (CE)



Rank 02
Vandit (EE)



Rank 03
Parvinder (ME)



Rank 06
Abhishek (ME)



Rank 06
Vivek (CE)



Rank 08
Kiran (CS)



Rank 09
Shivam (EC)



Rank 09
Tushar (EE)



Rank 10
Mitesh (CS)

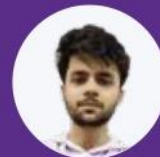

Rank 11
Kaustav (ME)



Rank 11
Souvik (ME)



Rank 12
Himanshu (CE)



Rank 15
Surya (CS)



Rank 18
Swastik (CE)



Rank 20
Lakshay (ME)



Rank 21
Tathagata (CS)



Rank 22
Ayush (CE)



Rank 29
Piyush (EE)



Rank 38
Rajat (EE)

Prepare with us & get placed in your dream college, PSU or department!

PSUs

ONGC

IOCL

PowerGrid

NTPC

Top Colleges

IISc Bangalore

IIT Madras

IIT Bombay

IIT Kharagpur

Departments through ESE

CPWD

Ministry of Power

Defence Services

Ordnance Services



Website: www.byjusexamprep.com

Address: Windsor IT Park, Tower - A, 2nd Floor,
Sector 125, Noida, Uttar Pradesh 201303

Name:

Contact no:

Email id:

Download The App

