

# CAT 2017 Slot-1 Question Paper & Solution



## SLOT-1 VARC

**Direction (Q1-6):** Read the passage carefully and answer the questions based on it.

Understanding where you are in the world is a basic survival skill, which is why we, like most species, come hard-wired with specialized brain areas to create cognitive maps of our surroundings. Where humans are unique, though, with the possible exception of honeybees, is that we try to communicate this understanding of the world with others. We have a long history of doing this by drawing maps – the earliest version yet discovered were scrawled on cave walls 14,000 years ago. Human cultures have been drawing them on stone tablets, papyrus, paper and now computer screens ever since.

Given such a long history of human map-making, it is perhaps surprising that it is only within the last few hundred years that the north has been consistently considered to be at the top. In fact, for much of human history, the north almost never appeared at the top, according to Jerry Brotton, a map historian... “North was rarely put at the top for the simple fact that north is where darkness comes from,” he says. “West is also very unlikely to be put at the top because west is where the sun disappears.”

Confusingly, early Chinese maps seem to buck this trend. But, Brotton, says, even though they did have compasses at the time, that isn't the reason that they placed north at the top. Early Chinese compasses were actually oriented to point south, which was considered to be more desirable than deepest darkest north. But in Chinese maps, the emperor, who lived in the north of the country was always put at the top of the map, with everyone else, his loyal subjects, looking up towards him. “In Chinese culture the Emperor looks south because it's where the winds come from, it's a good direction. North is not very good but you are in a position of subjection to the emperor, so you look up to him,” says Brotton.

Given that each culture has a very different idea of who, or what, they should look upto it's perhaps not surprising that there is very little consistency in which way early maps pointed. In ancient Egyptian times the top of the world was east, the position of sunrise. Early Islamic maps favoured south at the top because most of the early Muslim cultures were north of Mecca, so they imagined looking up (south) towards it. Christian maps from the same era (called Mappa Mundi) put east at the top, towards the Garden of Eden and with Jerusalem in the centre.

So when did everyone get together and decide that north was the top? It's tempting to put it down to European explorers like Christopher Columbus and Ferdinand Megellan who were navigating by the North Star. But Brotton argues that these early explorers didn't think of the world like that at all. “When Columbus describes the world it is in accordance with east being at the top,” he says “Columbus says he is going towards paradise, so his mentality is from a medieval mappa mundi.” We've got to remember, adds Brotton, that at the time, “no one knows what they are doing and where they are going.”

1. Which one of the following best describes what the passage is trying to do?
- A. It questions an explanation about how maps are designed.
  - B. It corrects a misconception about the way maps are designed.
  - C. It critiques a methodology used to create maps
  - D. It explores some myths about maps

**Answer:** B

**Solution:**

The question asks the author's purpose or objective. An understanding of the main idea will help you identify the correct answer.

The author says that the history of making maps is long but only within the last few hundred years north has been considered to be at the top of the map. For much of human history, the north almost never appeared at the top, but the Chinese went against this trend and put the north on the top. There is very little consistency in which way early maps pointed. The passage negates the theory or misconception that Columbus and Megallan started the trend as they navigated using the North star. Option A is not correct as it does not challenge one specific explanation on the design of maps- rather it tries to find out various possible reasons and explanations for the North being on top of the map and negates each one.

Option C is incorrect as it does not criticise or mention the methodology of creating maps.

Option D is incorrect as it is too general. The author is concerned only about when and why north was placed on top of maps. Not about myths about maps.

Option B is the right answer- There is a misconception that North is the natural direction for maps to point but the author corrects this misconception about the way maps are designed- that the North was not the natural or historical orientation of maps. It is a trend of the last few hundred years.

2. Early maps did NOT put north at the top for all the following reasons EXCEPT

- A. North was the source of darkness
- B. South was favoured by some emperors.
- C. East and south were more important for religious reasons for some civilisations
- D. East was considered by some civilisations to be a more positive direction

**Answer:** B

**Solution:**

The question asks for an exception to the reason for not having a north-oriented map.

Option A has been mentioned - refer to para 2 - "North was rarely put at the top for the simple fact that north is where darkness comes from,..."

Option B is the correct answer- it does not give a reason for why the North was not put on top-It is the reason for the Chinese maps being north oriented. Chinese emperors lived in the north of the country and faced the South and their subjects looked up to them facing North which is why Chinese maps placed North on the top Hence B is the answer.

C and D give the reasons why some civilisations such as early Egyptian, Christian, and Islamic civilisations did not put North on top and preferred East or South oriented maps.

3. According to the passage, early Chinese maps placed north at the top because
- A. the Chinese invented the compass and were aware of magnetic north
  - B. they wanted to show respect to the emperor.
  - C. the Chinese emperor appreciated the winds from the south.
  - D. north was considered the most desirable direction.

**Answer:** B

**Solution:**

Refer to the third paragraph, where the author states why Chinese maps were oriented to the North - 'But in Chinese maps, the emperor, who lived in the north of the country was always put at the top of the map, with everyone else, his loyal subjects, looking up towards him. "In Chinese culture the Emperor looks south because it's where the winds come from, it's a good direction"

Hence the correct answer is option B.

4. It can be inferred from the passage that European explorers like Columbus and Megellan

- A. set the precedent for north-up maps
- B. navigated by the compass
- C. used an eastward orientation for religious reasons
- D. navigated with the help of early maps

**Answer:** C

**Solution:**

The passage cites Columbus and Megellan in the concluding paragraph. The author argues that though the European travelers like Columbus and Magellan used the North Star for navigation, they did not believe in the North orientation of maps. They were headed east for religious reasons. Refer to the lines - But Brotton argues that these early explorers didn't think of the world like that at all. "When Columbus describes the world it is in accordance with east being at the top," he says. "Columbus says he is going towards paradise, so his mentality is from a medieval mappa mundi."

Hence the correct answer is option C.

5. Which one of the following about the northern orientation of modern maps is asserted in the passage?

- A. The biggest contributory factor was the understanding of magnetic north.
- B. The biggest contributory factor was the role of European explorers.
- C. The biggest contributory factor was the influence of Christian maps.
- D. The biggest contributory factor is not stated in the passage.

**Answer:** D

**Solution:**

The author explores various civilisations and their map orientations but does not give us a definitive answer on who or how the North oriented maps began.

Hence the correct answer is option D.

6. The role of natural phenomena in influencing map-making conventions is seen most clearly in

- A. early Egyptian maps
- B. early Islamic maps
- C. early Chinese maps
- D. early Christian maps

**Answer:** A

**Solution:**

A quick reading of the fourth paragraph gives the answer to the question. Refer to the lines - In ancient Egyptian times the top of the world was east, the position of sunrise.

Hence A is the answer.

Islamic maps had religious reasons for orienting their maps to the south as most Islamic civilizations were to the North of Mecca- so B is eliminated.

Chinese maps were oriented to the north to show respect to the Emperor , hence C is eliminated.

Early Christian maps followed the Mappa Mundi and were oriented to the east- for religious reasons. Hence D is eliminated.

**Direction (Q7-12):** Read the following passage carefully and answer the question based on it.

I used a smartphone GPS to find my way through the cobblestoned maze of Geneva's Old Town, in search of a handmade machine that changed the world more than any other invention. Near a 13th-century cathedral in this Swiss city on the shores of a lovely lake, I found what I was looking for: a Gutenberg printing press. "This was the Internet of its day — at least as influential as the iPhone," said Gabriel de Montmollin, the director of the Museum of the Reformation, toying with the replica of Johann Gutenberg's great invention. [Before the invention of the printing press] it used to take four monks...up to a year to produce a single book. With the advance in movable type in 15th-century Europe, one press could crank out 3,000 pages a day. Before long, average people could travel to places that used to be unknown to them — with maps! Medical information passed more freely and quickly, diminishing the sway of quacks...The printing press offered the prospect that tyrants would never be able to kill a book or suppress an idea. Gutenberg's brainchild broke the monopoly that clerics had on scripture. And later, stirred by pamphlets from a version of that same press, the American colonies rose up against a king and gave birth to a nation.

So, a question in the summer of this 10th anniversary of the iPhone: has the device that is perhaps the most revolutionary of all time given us a single magnificent idea? Nearly every advancement of the written word through new technology has also advanced humankind. Sure, you can say the iPhone changed everything. By putting the world's recorded knowledge in the palm of a hand, it revolutionized work, dining, travel and socializing. It made us more narcissistic — here's more of me doing cool stuff! — and it unleashed an army of awful trolls. We no longer have the patience to sit through a baseball game without that reach to the pocket. And one more casualty of Apple selling more than a billion phones in a decade's time: daydreaming has become a lost art.

For all of that, I'm still waiting to see if the iPhone can do what the printing press did for religion and democracy...the Geneva museum makes a strong case that the printing press opened more minds than anything else...it's hard to imagine the French or American revolutions without those enlightened voices in print...

Not long after Steve Jobs introduced his iPhone, he said the bound book was probably headed for history's attic. Not so fast. After a period of rapid growth in e-books, something closer to the medium for Chaucer's volumes has made a great comeback. The hope of the iPhone, and the Internet in general, was that it would free people in closed societies. But the failure of the Arab Spring, and the continued suppression of ideas in North Korea, China and Iran, has not borne that out... The iPhone is still



young. It has certainly been "one of the most important, world-changing and successful products in history, " as Apple CEO. Tim Cook said. But I'm not sure if the world changed for the better with the iPhone — as it did with the printing press — or merely, changed.

7. The printing press has been likened to the Internet for which one of the following reasons?

- A. It enabled rapid access to new information and the sharing of new ideas
- B. It represented new and revolutionary technology compared to the past
- C. It encouraged reading among people by giving them access to thousands of books
- D. It gave people access to pamphlets and literature in several languages

**Answer:** A

**Solution:**

A quick reading of the second paragraph will help identify the answer easily - the author compared the printing press to the internet because the printing press resulted in fast and effective information sharing. He gives examples of how slow and inaccessible information was before the printing press.

Hence A is the answer.

Option B is a fact but does not bring out the similarities in the effect of the internet and the printing press to the civilisations of their time.

Options C and D mention the various advantages of the internet and printing press which are covered under the broad term information and sharing of new ideas.

Hence option A is the correct answer.

8. According to the passage, the invention of the printing press did all of the following EXCEPT

- A. Promoted the spread of enlightened political views across countries.
- B. Gave people direct access to authentic medical information and religious texts.
- C. Shortened the time taken to produce books and pamphlets.
- D. Enabled people to perform various tasks simultaneously.

**Answer:** D

**Solution:**

We have to look for an option which is not correct about the printing press.

Option A is true about the printing press. Refer to the lines in paragraph 3 -the Geneva museum makes a strong case that the printing press opened more minds than anything else...it's hard to imagine the French or American revolutions without those enlightened voices in print...So, it is correct to say it promoted enlightened political views among countries.

Option B is true - Refer to the lines in Para 1- Medical information passed more freely and quickly, diminishing the sway of quacks.

Option C is true according to the following lines of the first para- With the advance in movable type in 15th-century Europe, one press could crank out 3,000 pages a day.

Option D is the answer- Nowhere is it stated in the passage that people could multitask as a result of the invention of the printing press.

9. Steve Jobs predicted which one of the following with the introduction of the iPhone?

- A. People would switch from reading on the Internet to reading on their iPhones.
- B. People would lose interest in historical and traditional classics.
- C. Reading printed books would become a thing of the past.
- D. The production of e-books would eventually fall.

**Answer:** C

**Solution:**

Refer to the lines of para 4 where the author mentions Steve Jobs - Not long after Steve Jobs introduced his iPhone, he said the bound book was probably headed for history's attic.

So Steve Jobs believed that printed books would be consigned to history or become obsolete with the introduction of the iPhone.

This is best expressed in option C.

10. "I'm still waiting to see if the iPhone can do what the printing press did for religion and democracy." The author uses which one of the following to indicate his uncertainty?

- A. The rise of religious groups in many parts of the world.
- B. The expansion in trolling and narcissism among users of the Internet
- C. The continued suppression of free speech in closed societies
- D. The decline in reading habits among those who use the device

**Answer:** C

**Solution:**

A reading of paragraph 3 and the conclusion paragraph of the passage will help understand the quote. The given statement is in paragraph 3 of the passage where the author mentions it in the context of the Gutenberg press spreading the words of enlightened voices and helping revolutions come about. In the concluding paragraph, the author says 'The hope of the iPhone, and the Internet in general, was that it would free people in closed societies. But the failure of the Arab Spring, and the continued suppression of ideas in North Korea, China and Iran, has not borne that out.'

So we can infer that the author believes that the internet has not succeeded in doing what the printing press did. It has not been able to free people in closed societies.

Hence option C is the correct answer.

11. The author attributes the French and American revolutions to the invention of the printing press because

- A. maps enabled large numbers of Europeans to travel and settle in the American continent.
- B. the rapid spread of information exposed people to new ideas on freedom and democracy
- C. it encouraged religious freedom among the people by destroying the monopoly of religious leaders on the scriptures.
- D. it made available revolutionary strategies and opinions to the people.

**Answer:** B

**Solution:**

The answer to this question lies in the third paragraph- refer to the lines'.. .the Geneva museum makes a strong case that the printing press opened more minds than anything else...it's hard to imagine the French or American revolutions without those enlightened voices in print...From this we can infer that without the spreading of information and ideas from enlightened voices, the French and American revolutions would not have been possible.

Hence option B is the correct answer.

12. The main conclusion of the passage is that the new technology has
- A. some advantages, but these are outweighed by its disadvantages.
  - B. so far not proved as successful as the printing press in opening people's minds
  - C. been disappointing because it has changed society too rapidly
  - D. been more wasteful than the printing press because people spend more time daydreaming or surfing.

**Answer:** B

**Solution:**

The overall argument of the author on the new technology has been summed up in the concluding paragraph. Refer to the lines - 'The hope of the iPhone, and the Internet in general, was that it would free people in closed societies. But the failure of the Arab Spring, and the continued suppression of ideas in North Korea, China and Iran, has not borne that out...'

But I'm not sure if the world changed for the better with the iPhone — as it did with the printing press — or merely, changed.

This is best expressed in option B.

Option A is too general and can be eliminated.

Option C is also eliminated as the author's main point is not about the pace of change but the kind of change effected by the new technology.

D is irrelevant. The author in fact says people do not day dream anymore.

Hence option B is the correct choice.

**Direction (Q13-18):** Read the following passage carefully and answer the question based on it.

This year alone, more than 8,600 stores could close, according to industry estimates, many of them the brand -name anchor outlets that real estate developers once stumbled over themselves to court. Already there have been 5,300 retail closings this year... Sears Holdings—which owns Kmart—said in March that there's "substantial doubt" it can stay in business altogether, and will close 300 stores this year. So far this year, nine national retail chains have filed for bankruptcy.

Local jobs are a major casualty of what analysts are calling, with only a hint of hyperbole, the retail apocalypse. Since 2002, department stores have lost 448,000 jobs, a 25% decline, while the number of store closures this year is on pace to surpass the worst depths of the Great Recession. The growth of online retailers, meanwhile, has failed to offset those losses, with the e- commerce sector adding just 178,000 jobs over the past 15 years. Some of those jobs can be found in the massive distribution centers Amazon has opened across the country, often not too far from malls the company helped shutter.

But those are workplaces, not gathering places. The mall is both. And in the 61 years since the first enclosed one opened in suburban Minneapolis, the shopping mall has been where a huge swath of middle-class America went for far more than shopping. It was the home of first jobs and blind dates, the place for family photos and ear piercings, where goths and grandmothers could somehow walk through the same doors and find something they all liked. Sure, the food was lousy for you and the oceans of parking lots encouraged car-heavy development, something now scorned by contemporary planners. But for better or worse, the mall has been America's public square for the last 60 years.

So what happens when it disappears?



Think of your mall. Or think of the one you went to as a kid. Think of the perfume clouds in the department stores. The fountains splashing below the skylights. The cinnamon wafting from the food court. As far back as ancient Greece, societies have congregated around a central marketplace. In medieval Europe, they were outside cathedrals. For half of the 20th century and almost 20 years into the new one, much of America has found their agora on the terrazzo between Orange Julius and Sbarro, Waldenbooks and the Gap, Sunglass Hut and Hot Topic.

That mall was an ecosystem unto itself, a combination of community and commercialism peddling everything you needed and everything you didn't: Magic Eye posters, wind catchers. Air Jordans. ...

A growing number of Americans, however, don't see the need to go to any Macy's at all. Our digital lives are frictionless and ruthlessly efficient, with retail and romance available at a click. Malls were designed for leisure, abundance, ambling. You parked and planned to spend some time. Today, much of that time has been given over to busier lives and second jobs and apps that let you swipe right instead of haunt the food court. 'Malls, says Harvard business professor Leonard Schlesinger, "were built for patterns of social interaction that increasingly don't exist."

13. The central idea of this passage is that:

- A. the closure of malls has affected the economic and social life of middle-class America
- B. the advantages of malls outweigh their disadvantages.
- C. malls used to perform a social function that has been lost
- D. malls are closing down because people have found alternate ways to shop.

**Answer: C**

**Solution:**

The passage is about malls and disappearing mall culture. The author starts by citing statistics on stores closing and bankruptcies of retail chains. The result of this is the loss of local jobs. Some of the people have found employment in the distribution centres of online stores such as Amazon. But the closure of stores and malls has meant the disappearance of mall culture and ecosystem which was a combination of community and commercialism. In the concluding lines of the passage the author sums up his argument saying malls 'were built for patterns of social interaction that increasingly don't exist."

So we can say that the main idea of the passage is the disappearing mall culture - which is best expressed in C.

A is incorrect as it is the Americans' changing way of life which led to the closure of malls, not the other way around. Refer to the lines-' A growing number of Americans, however, don't see the need to go to any Macy's at all. Our digital lives are frictionless and ruthlessly efficient'

B is irrelevant and also incorrect. Malls had a purpose in the past but not any longer. So we cannot say the main argument of the author is to say malls had more advantages.

D is a fact mentioned in the passage but not the central idea- the central idea is the change in the culture which has made malls redundant.

14. Why does the author say in paragraph 2, 'the massive distribution centers Amazon has opened across the country, often not too far from malls the company helped shutter'?

- A. To highlight the irony of the situation
- B. To indicate that malls and distribution centres are located in the same area
- C. To show that Amazon is helping certain brands go online
- D. To indicate that the shopping habits of the American middle class have changed.

**Answer:** A

**Solution:**

Irony is a state of affairs that is contrary to what one expects - so an online distribution centre standing in the same place as a store it was responsible for closing is an ironic situation.

Hence option A is the correct answer.

15. In paragraph 1, the phrase "real-estate developers once stumbled over themselves to court" suggests that they

- A. took brand-name anchor outlets to court.
- B. no longer pursue brand-name hanger outlets
- C. malls are closing down because people have found alternate ways to shop
- D. collaborated with one another to get brand-name anchor outlets.

**Answer:** B

**Solution:**

The statement literally means that real-estate developers pushed and shoved each other out of the way to try to win the support of a retail chain to open their brand outlet on their premises. This means that earlier real-estate developers were pursuing brand-name anchor outlets- they are not doing it anymore.

Hence the correct answer is option B.

16. The author calls the mall an ecosystem unto itself because

- A. people of all ages and from all walks of life went there
- B. people could shop as well as eat in one place
- C. it was a commercial space as well as a gathering place.
- D. it sold things that were needed as well as those that were not.

**Answer:** C

**Solution:**

Refer to the lines where the author uses the term ecosystem -'That mall was an ecosystem unto itself, a combination of community and commercialism peddling everything you needed and everything you didn't: Magic Eye posters, wind catchers, Air Jordans.'

In the lines preceding this, the author mentions how malls were both workplaces and gathering places. They were like public squares where many things happened- a blend of community and commerce.

This has been expressed best in option C.

17. Why does the author say that the mall has been America's public square?

- A. Malls did not bar anybody from entering the space
- B. Malls were a great place to shop for a huge section of the middle class
- C. Malls were a hangout place where families grew close to each other
- D. Malls were a great place for everyone to gather and interact.

**Answer:** D

**Solution:**

The author calls the malls America's public square. Then he describes public squares in ancient cultures which served as social gathering places. The malls in America similarly were not just meant for shopping but for social gatherings as well.

This is best expressed in option D.

Option A can be eliminated as restrictions or access to all have not been mentioned in the passage.

Option B is eliminated as it mentions only the shopping aspect, not the social function of a mall. So it's too narrow in scope.

Option C mentions only family interactions ignoring the shopping or commercial aspect and interaction with others in society.

Hence option D is the correct answer.

18. The author describes 'Perfume clouds in the department stores' in order to: -

A. evoke memories by painting a picture of malls

B. describe the smells and sights of malls

C. emphasise that all brands were available under one roof.

D. show that malls smelt good because of the various stores and food court.

**Answer:** A

**Solution:**

The question asks the function or purpose of an expression.

Refer to the lines where the expression has been used in paragraph 4 as an answer to the question- So what happens when it disappears?

Think of your mall. Or think of the one you went to as a kid. Think of the perfume clouds in the department stores.

The author asks the reader to think of a mall and remember how it was - So the purpose of the 'perfume clouds' or other things he mentions are to make the reader remember the mall experience - So he mentions them to evoke the memory of malls. Hence the correct answer is option A.

B is not correct. The word 'describe' is incorrect- the author wants the reader to remember the sights and sounds - not to describe them.

C talks of brands which are irrelevant to the expression.

D does not capture the author's intention in asking the readers to think of the sights and smells of the mall- the point is not to prove or demonstrate that malls had food courts and stores which smelt good- he wants the reader to remember them.

**Direction (Q19-21):** Read the following passage carefully and answer the question based on it.

Scientists have long recognised the incredible diversity within a species. But they thought it reflected evolutionary changes that unfolded imperceptibly, over millions of years. That divergence between populations within a species was enforced, according to Ernst Mayr, the great evolutionary biologist of the 1940s, when a population was separated from the rest of the species by a mountain range or a desert, preventing breeding across the divide over geologic scales of time. Without the separation, gene flow was relentless. But as the separation persisted, the isolated population grew apart and speciation occurred.

In the mid-1960s, the biologist Paul Ehrlich - author of *The Population Bomb* (1968) - and his Stanford University colleague Peter Raven challenged Mayr's ideas about speciation. They had studied checkerspot butterflies living in the Jasper Ridge Biological Preserve in California, and it soon became clear that they were not

examining a single population. Through years of capturing, marking and then recapturing the butterflies, they were able to prove that within the population, spread over just 50 acres of suitable checkerspot habitat, there were three groups that rarely interacted despite their very close proximity.

Among other ideas, Ehrlich and Raven argued in a now classic paper from 1969 that gene flow was not as predictable and ubiquitous as Mayr and his cohort maintained, and thus evolutionary divergence between neighbouring groups in a population was probably common. They also asserted that isolation and gene flow were less important to evolutionary divergence than natural selection (when factors such as mate choice, weather, disease or predation cause better-adapted individuals to survive and pass on their successful genetic traits). For example, Ehrlich and Raven suggested that, without the force of natural selection, an isolated population would remain unchanged and that, in other scenarios, natural selection could be strong enough to overpower gene flow...

19. Which of the following best sums up Ehrlich and Raven's argument in their classic 1969 paper?

- A. Ernst Mayr was wrong in identifying physical separation as the cause of species diversity
- B. Checkerspot butterflies in the 50-acre Jasper Ridge Preserve formed three groups that rarely interacted with each other
- C. While a factor, isolation was not as important to speciation as natural selection
- D. Gene flow is less common and more erratic than Mayr and his colleagues claimed.

**Answer:** C

**Solution:**

The concluding paragraph has Ehrlich and Raven's main argument. Refer to the lines -'...Ehrlich and Raven argued in a now classic paper from 1969 that gene flow was not as predictable and ubiquitous as Mayr and his cohort maintained, and thus evolutionary divergence between neighbouring groups in a population was probably common.' **They also asserted that isolation and gene flow were less important to evolutionary divergence than natural selection.**

Now let's look at the options.

Option A can be eliminated as it mentions how Mayr was wrong, it does not state the main point of Ehrlich and Raven.

Option-B can also be eliminated as it only mentions what Ehrlich and Raven observed-their findings but not their main argument.

Option D is also incorrect as it points to a flaw in Mayr's theory but does not sum up Ehrlich and Raven's main argument.

The correct answer is option C.

C states 'While a factor, isolation was not as important to speciation as natural selection which is the same as **isolation and gene flow were less important to evolutionary divergence than natural selection.**

Hence option C is the correct answer.

20. All of the following statements are true according to the passage EXCEPT

- A. Gene flow contributes to evolutionary divergence.
- B. The Population Bomb questioned dominant ideas about species diversity
- C. Evolutionary changes unfold imperceptibly over time.
- D. Checkerspot butterflies are known to exhibit speciation while living in close proximity

**Answer:** B

**Solution:**

We have to identify the statement which is not true.

A is true - it is mentioned in the lines of the concluding para - 'isolation and gene flow were less important to evolutionary divergence than natural selection' So we can say isolation, gene flow, and evolutionary divergence are all important but the last mentioned is more important.

Option B is incorrect according to the information given in the passage- read the following lines of the 2nd paragraph - '**In the mid-1960s, the biologist Paul Ehrlich - author of The Population Bomb (1968) - and his Stanford University colleague Peter Raven challenged Mayr's ideas about speciation.**

The passage mentions that (1) Ehrlich was the author of the book the Population Bomb and (2) Ehrlich and Raven challenged Mayr's ideas about speciation.

But it does not mention that the book questions dominant ideas about species diversity.

Hence option B is the correct answer.

21. The author discusses Mayr, Ehrlich and Raven to demonstrate that

- A. evolution is a sensitive and controversial topic
- B. Ehrlich and Raven's ideas about evolutionary divergence are widely accepted by scientists.
- C. the causes of speciation are debated by scientists
- D. checkerspot butterflies offer the best example of Ehrlich and Raven's ideas about speciation

**Answer:** C

**Solution:**

The author mentions these three scientists to discuss their work and theories on speciation.

A is incorrect as it has not been mentioned.

B - is incorrect as the author first mentions Mayr and his theory and then Ehrlich and Raven's counter to Mayr's claims. He does not say the latter are widely accepted.

C is the right answer- The author says scientists have recognised the incredible diversity within a species. Then he mentions Mayr and his theory on speciation and then Ehrlich and Raven's thesis on speciation which contradicts Mayr's - So we can say that he discusses these three in the context of the debate on speciation among scientists.

**Direction (Q22-24):** Read the following passage carefully and answer the questions based on it.

Do sports mega events like the summer Olympic Games benefit the host city economically? It depends, but the prospects are less than rosy. The trick is converting...several billion dollars in operating costs during the 17-day fiesta of the Games into a basis for long-term economic returns. These days, the summer Olympic Games themselves generate total revenue of \$4 billion to \$5 billion, but the lion's



share of this goes to the International Olympics Committee, the National Olympics Committees and the International Sports Federations. Any economic benefit would have to flow from the value of the Games as an advertisement for the city, the new transportation and communications infrastructure that was created for the Games, or the ongoing use of the new facilities.

Evidence suggests that the advertising effect is far from certain. The infrastructure benefit depends on the initial condition of the city and the effectiveness of the planning. The facilities benefit is dubious at best for buildings such as velodromes or natatoriums and problematic for 100,000-seat Olympic stadiums. The latter require a conversion plan for future use, the former are usually doomed to near vacancy. Hosting the summer Games generally requires 30-plus sports venues and dozens of training centers. Today, the Bird's Nest in Beijing sits virtually empty, while the Olympic Stadium in Sydney costs some \$30 million a year to operate.

Part of the problem is that Olympics planning takes place in a frenzied and time-pressured atmosphere of intense competition with the other prospective host cities — not optimal conditions for contemplating the future shape of an urban landscape. Another part of the problem is that urban land is generally scarce and growing scarcer. The new facilities often stand for decades or longer. Even if they have future use, are they the best use of precious urban real estate?

Further, cities must consider the human cost. Residential areas often are razed and citizens relocated (without adequate preparation or compensation). Life is made more hectic and congested. There are, after all, other productive uses that can be made of vanishing fiscal resources.

22. The central point in the first paragraph is that the economic benefits of the Olympic Games

- A. are shared equally among the three organising committees
- B. accrue mostly through revenue from advertisements and ticket sales
- C. accrue to host cities, if at all, only in the long term
- D. are usually eroded by expenditure incurred by the host city

**Answer:** C

**Solution:**

A quick reading of the first paragraph will help you identify the answer easily. Refer to the lines - 'Do sports mega events... benefit the host city economically? It depends, but the prospects are less than rosy. **The trick is converting...several billion dollars in operating costs during the 17-day fiesta of the Games into a basis for long-term economic returns.**'

Option A is incorrect as it is not the main point on the economic benefits - it just mentions who gets a share of the revenues generated from the event.

Option B is not correct since revenue from ticket sales and ads have not been mentioned.

Option C is correct as the author says in the first paragraph that if at all there are any benefits - they are long-term benefits. In the words of the author, the host city can benefit from sports events if they can convert the expenditure into long-term economic returns.

Hence option C is the correct answer.

23. Sports facilities built for the Olympics are not fully utilised after the Games are over because

- A. their scale and the costs of operating them are large
- B. their location away from the city centre usually limits easy access.
- C. the authorities do not adapt them to local conditions.
- D. they become outdated having been built with little planning and under time pressure

**Answer:** A

**Solution:**

The author mentions sports facilities in the second para- refer to the lines - 'The facilities benefit is dubious at best for buildings such as velodromes or natatoriums and problematic for 100,000-seat Olympic stadiums. The latter require a conversion plan for future use, the former are usually doomed to near vacancy. Hosting the summer Games generally requires 30-plus sports venues and dozens of training centers. Today, the Bird's Nest in Beijing sits virtually empty, while the Olympic Stadium in Sydney costs some \$30 million a year to operate.'

From this he mentions that the facilities can't really be utilised as they are huge (refer to the seating capacities mentioned) and costly to maintain (Olympic Stadium, Sydney)

These points have been mentioned in option A.

Hence option A is the correct answer.

B is eliminated as the passage does not mention that the facilities are located away from the city centre.

C is out of scope as lack of adaptability to local conditions has not been mentioned.

D is also not correct since the author does not mention lack of planning, etc. in the context of sports facilities.

24. The author feels that the Games place a burden on the host city for all of the following reasons EXCEPT that

- A. they divert scarce urban land from more productive uses
- B. they involve the demolition of residential structures to accommodate sports facilities and infrastructure
- C. the finances used to fund the Games could be better used for other purposes.
- D. the influx of visitors during the Games places a huge strain on the urban infrastructure.

**Answer:** D

**Solution:**

We have to identify the option which does not state why the games are a burden on the host city

Option-A has been mentioned in these lines - "Even if they have future use, are they the best use of precious urban real estate".

Option-B has been mentioned in the lines - "Residential areas often are razed ... citizens relocated".

Option-C can be inferred from the last lines of the passage - "other productive uses that can be made of vanishing fiscal resources".

Option D is the correct answer. The influx of visitors has not been mentioned as a problem for the host cities.

**25.Direction:** The passage given below is followed by four summaries. Choose the option that best captures the author's position.

A translator of literary works needs a secure hold upon the two languages involved, supported by a good measure of familiarity with the two cultures. For an Indian translating works in an Indian language into English, finding satisfactory equivalents in a generalized western culture of practices and symbols in the original would be less difficult than gaining fluent control of contemporary English. When a westerner works on texts in Indian languages the interpretation of cultural elements will be the major challenge, rather than control over the grammar and essential vocabulary of the language concerned. It is much easier to remedy lapses in language in a text translated into English, than flaws of content. Since it is easier for an Indian to learn the English language than it is for a Briton or American to comprehend Indian culture, translations of Indian texts are better left to Indians.

A. While translating, the Indian and the westerner face the same challenges but they have different skill profiles and the former has the advantage.

B. As preserving cultural meanings is the essence of literary translation, Indians' knowledge of the local culture outweighs the initial disadvantage of lower fluency in English.

C. Indian translators should translate Indian texts into English as their work is less likely to pose cultural problems which are harder to address than the quality of language.

D. Westerners might be good at gaining reasonable fluency in new languages, but as understanding the culture reflected in literature is crucial, Indians remain better placed.

**Answer:** C

**Solution:**

The given passage is on translation. The main points of the passage are-

A translator of literary works needs to know the two languages involved and be familiar with the two cultures.

For an Indian translating works in an Indian language into English, finding equivalents in western culture of practices and symbols in the original would be less difficult than gaining fluency in English.

When a westerner works on texts in Indian languages, the interpretation of cultural elements will be the major challenge, rather than control over the language concerned.

Since it is easier for an Indian to learn the English language than it is for a Briton or American to comprehend Indian culture, translations of Indian texts are better left to Indians.

Now let's look at the options-

Option A is too general- it mentions that Indians are at an advantage but does not mention the context, i.e., while translating Indian texts.

Option B is not a complete summary. It only mentions the Indian translator's knowledge of the local culture- does not mention western translators or the translation of Indian texts.

Option D is also too general- the main point of the passage is that Indians are better off when translating Indian texts- this point has not been mentioned in D.

Option C captures the essence of the passage best- it mentions all the points Indian translators are better off translating Indian texts as they understand the cultural elements better which are harder to address than the quality of language.

**26.Direction:** The passage given below is followed by four summaries. Choose the option that best captures the author's position.

For each of the past three years, temperatures have hit peaks not seen since the birth of meteorology, and probably not for more than 110,000 years. The amount of carbon dioxide in the air is at its highest level in 4 million years. This does not cause storms like Harvey - there have always been storms and hurricanes along the Gulf of Mexico - but it makes them wetter and more powerful. As the seas warm, they evaporate more easily and provide energy to storm fronts. As the air above them warms, it holds more water vapour. For every half a degree Celsius in warming, there is about a 3% increase in atmospheric moisture content. Scientists call this the Clausius-Clapeyron equation. This means the skies fill more quickly and have more to dump. The storm surge was greater because sea levels have risen 20 cm as a result of more than 100 years of human-related global warming which has melted glaciers and thermally expanded the volume of sea water.

A. The storm Harvey is one of the regular., annual ones from the Gulf of Mexico; global warming and Harvey are unrelated phenomena.

B. Global warming does not breed storms but makes them more destructive; the Clausius-Clapeyron equation, though it predicts potential increase in atmospheric moisture content, cannot predict the scale of damage storms might wreck.

C. Global warming melts glaciers, resulting in sea water volume expansion; this enables more water vapour to fill the air above faster. Thus, modern storms contain more destructive energy.

D. It is naive to think that rising sea levels and the force of tropical storms are unrelated; Harvey was destructive as global warming has armed it with more moisture content, but this may not be true of all storms.

**Answer:** C

**Solution:**

The passage is about global warming and its effects- it says high temperature and high levels of carbon dioxide makes storms wetter and more powerful. Global warming results in melting glaciers, increasing sea level, and more powerful storms. Option A contradicts the facts mentioned in the paragraph by stating that global warming and storms are unrelated.

Option B mentions the Clausius-Clapeyron equation and its limitations, which is not the main point of the paragraph.

Option D is wordy and uses ambiguous expressions.

Option C mentions all the important points of the paragraph concisely. Hence option C is the correct answer.

**27.Direction:** The five sentences (labelled 1, 2, 3, 4, 5) given in this question, when properly sequenced, form a coherent paragraph. Each sentence is labelled with a number. Decide on the proper order for the sentence and key in this sequence of five numbers as your answer.

1) The process of handing down implies not a passive transfer, but some contestation in defining what exactly is to be handed down.

2) Wherever Western scholars have worked on the Indian past, the selection is even more apparent and the inventing of a tradition much more recognizable.

- 3) Every generation selects what it requires from the past and makes its innovations, some more than others.
- 4) It is now a truism to say that traditions are not handed down unchanged, but are invented.
- 5) Just as life has death as its opposite, so is tradition by default the opposite of innovation.

**Answer:** 54132

**Solution:**

Reading all the sentences in the jumble, 5 is clearly the starting sentence as it introduces the subject of tradition and innovation

4 can follow 5 as it continues on the theme of traditions.

1 expands on the point mentioned in 4- how traditions are not just handed down but are invented by not being a passive transfer.

3 elaborates on the 'contestation on what exactly has to be handed down' given in 1 - each generation selects what it requires.

3-2 is a pair as 2 continues to talk about 'the selection' mentioned in 3.

Hence the correct order is 54132.

**28.Direction:** The five sentences (labelled 1, 2, 3, 4, 5) given in this question, when properly sequenced, form a coherent paragraph. Each sentence is labelled with a number. Decide on the proper order for the sentence and key in this sequence of five numbers as your answer.

1) Scientists have for the first time managed to edit genes in a human embryo to repair a genetic mutation, fuelling hopes that such procedures may one day be available outside laboratory conditions.

2) The cardiac disease causes sudden death in otherwise healthy young athletes and affects about one in 500 people overall.

3) Correcting the mutation in the gene would not only ensure that the child is healthy but also prevents transmission of the mutation to future generations.

4) It is caused by a mutation in a particular gene and a child will suffer from the condition even if it inherits only one copy of the mutated gene.

5) In results announced in Nature this week, scientists fixed a mutation that thickens the heart muscle, a condition called hypertrophic cardiomyopathy.

**Answer:** 15243

**Solution:**

A quick reading of the jumble shows that 2-4-3 are linked.

Sentence 1 starts the sequence as it mentions what scientists have found for the first time about genetic mutation.

5 follows 1 as it elaborates on the work of the scientists on hypertrophic cardiomyopathy.

2 follows 5 as it mentions what happens in this disease or condition.

3 sums up the paragraph by stating how correcting the mutation helps.

Hence 15243.

**29.Direction:** The five sentences (labelled 1, 2, 3, 4, 5) given in this question, when properly sequenced, form a coherent paragraph. Each sentence is labelled with a number. Decide on the proper order for the sentence and key in this sequence of five numbers as your answer.

1.The study suggests that the disease did not spread with such intensity, but that it may have driven human migrations across Europe and Asia.



2.The oldest sample came from an individual who lived in southeast Russia about 5,000 years ago.

3.The ages of the skeletons correspond to a time of mass exodus from today's Russia and Ukraine into western Europe and central Asia, suggesting that a pandemic could have driven these migrations.

4.In the analysis of fragments of DNA from 101 Bronze Age skeletons for sequences from *Yersinia pestis*, the bacterium that causes the disease, seven tested positive.

5.DNA from Bronze Age human skeletons indicate that the black plague could have emerged as early as 3,000 BCE, long before the epidemic that swept through Europe in the mid-1300s.

**Answer:** 54123

**Solution:**

A reading of the sentences in the jumble shows that 5 is the starting sentence of the sequence as it is a general stand alone statement on the subject of the paragraph that is the black plague.

4 follows 5 as it elaborates on the result of the examination of DNA fragments mentioned in 5.

1 and 2 form a mandatory pair - 2 mentions the evidence of the study mentioned in 1.

3 follows 2 as it talks of the ages of the samples/ skeletons.

Hence the correct order is 54123.

30.**Direction:** The five sentences (labelled 1, 2, 3, 4, 5) given in this question, when properly sequenced, form a coherent paragraph. Each sentence is labelled with a number. Decide on the proper order for the sentence and key in this sequence of five numbers as your answer.

1) This visual turn in social media has merely accentuated this announcing instinct of ours, enabling us with easy-to-create, easy-to-share, easy-to-store and easy-to-consume platforms, gadgets and apps.

2) There is absolutely nothing new about us framing the vision of who we are or what we want, visually or otherwise, in our Facebook page, for example.

3) Turning the pages of most family albums, which belong to a period well before the digital dissemination of self-created and self-curated moments and images, would reconfirm the basic instinct of documenting our presence in a particular space, on a significant occasion, with others who matter.

4) We are empowered to book our faces and act as celebrities within the confinement of our respective friend lists, and communicate our activities, companionship and locations with minimal clicks and touches.

5) What is unprecedented is not the desire to put out news feeds related to the self, but the ease with which this broadcast operation can now be executed, often provoking (un)anticipated responses from beyond one's immediate location.

**Answer:** 32145

**Solution:**

When we read all the sentences in the jumble, we can identify 3 as the starting sentence - it introduces the subject of photographs and 'the basic instinct of documenting our presence in a particular space, on a significant occasion, with others who matter.'

2 expands on this idea by stating 'There is absolutely nothing new about us framing the vision of who we are or what we want, visually...'

1 follows 2 as it takes up the example of facebook in 2 and expands on it.

4 builds on the theme further.

5 sums up by stating that its not the desire to share our news that is unprecedented but ease with which this broadcast operation can now be executed.

Hence the correct order is 32145.

**31.Direction:** Five sentences related to a topic are given below. Four of them can be put together to form a meaningful and coherent short paragraph. Identify the odd one out. Choose its number as your answer and key it in.

1) People who study children's language spend a lot of time watching how babies react to the speech they hear around them.

2) They make films of adults and babies interacting, and examine them very carefully to see whether the babies show any signs of understanding what the adults say.

3) They believe that babies begin to react to language from the very moment they are born.

4) Sometimes the signs are very subtle - slight movements of the baby's eyes or the head or the hands.

5) You'd never notice them if you were just sitting with the child, but by watching a recording over and over, you can spot them.

**Answer:** 3

**Solution:**

We have to identify the sentence that does not belong to the set.

A reading of the sentences shows that all of them seem to be on the same theme -

So we have to arrange the sentences in order to find out which one does not belong.

Sentence 1 begins the sequence as it is a general sentence about how people who study children's language do so.

Sentence 2 follows 1. The "they" in sentence 2 refer to the people who study children's language. 2 states that they make films and examine them carefully - looking for any 'signs' the children make to show they understand an adult's language.

4 follows 2 as it continues about the 'signs'- it says that sometimes the signs are subtle.

5 follows 4 - You'd never notice them- the 'them' in 5 refers to the signs.

Hence 1-2-4-5 form a set and the odd one out is sentence 3.

**32.Direction:** Five sentences related to a topic are given below. Four of them can be put together to form a meaningful and coherent short paragraph. Identify the odd one out. Choose its number as your answer and key it in.

1) Neuroscientists have just begun studying exercise's impact within brain cells — on the genes themselves.

2) Even there, in the roots of our biology, they've found signs of the body's influence on the mind.

3) It turns out that moving our muscles produces proteins that travel through the bloodstream and into the brain, where they play pivotal roles in the mechanisms of our highest thought processes.

4) In today's technology-driven, plasma-screened-in world, it's easy to forget that we are born movers — animals, in fact — because we've engineered movement right out of our lives.

5) It's only in the past few years that neuroscientists have begun to describe these factors and how they work, and each new discovery adds awe-inspiring depth to the picture

**Answer:** 4

**Solution:**

The overall theme of the passage is the impact of exercise on the brain - 1,2,3, and 5 are related to this theme.

4 is clearly the odd one out as it is on an entirely different theme.

33. **Direction:** Five sentences related to a topic are given below. Four of them can be put together to form a meaningful and coherent short paragraph. Identify the odd one out. Choose its number as your answer and key it in.

1) The water that made up ancient lakes and perhaps an ocean was lost.

2) Particles from the Sun collided with molecules in the atmosphere, knocking them into space or giving them an electric charge that caused them to be swept away by the solar wind.

3) Most of the planet's remaining water is now frozen or buried, but clues over the past decade suggested that some liquid water, a presumed necessity for life, might survive in underground aquifers.

4) Data from NASA's MAVEN orbiter show that solar storms stripped away most of Mars's once-thick atmosphere.

5) A recent study reveals how Mars lost much of its early water, while another indicates that some liquid water remains.

**Answer:** 1

**Solution:**

One has to read the sentences and form a sequence to find the odd one out-

Sentence 5 is the starting sentence as it is a general statement on 2 studies- one on how Mars lost much of its water and another that there is still some water.

4-2 follow this as both relate to how Mars lost most of its water.

3 follows as it mentions the water remaining.

So we can see 5 4 2 3 is a coherent sequence.

Hence the odd one out is 4- which looks like a starting sentence of a different piece of writing on Mars.

Hence 4 is the odd one out.

34. **Direction:** The passage given below is followed by four summaries. Choose the option that best captures the author's position.

To me, a "classic" means precisely the opposite of what my predecessors understood: a work is classical by reason of its resistance to contemporaneity and supposed universality, by reason of its capacity to indicate human particularity and difference in that past epoch. The classic is not what tells me about shared humanity—or, more truthfully put, what lets me recognize myself as already present in the past, what nourishes in me the illusion that everything has been like me and has existed only to prepare the way for me. Instead, the classic is what gives access to radically different forms of human consciousness for any given generation of readers, and thereby expands for them the range of possibilities of what it means to be a human being.

A. A classic is able to focus on the contemporary human condition and a unified experience of human consciousness

B. A classical work seeks to resist particularity and temporal difference even as it focuses on a common humanity

C. A classic is a work exploring the new., going beyond the universal, the contemporary, and the notion of a unified human consciousness

D. A classic is a work that provides access to a universal experience of the human race as opposed to radically different forms of human consciousness

**Answer:** C

**Solution:**

A quick reading of the summary shows that the important part of the passage are the concluding lines- ' Instead, the classic is what gives access to radically different forms of human consciousness for any given generation of readers, and thereby expands for them the range of possibilities of what it means to be a human being.'

The author of the paragraph states that for him a classic gives access to very different forms of human consciousness for any generation of readers, increasing their range of different possibilities of what it means to be a human being.

Options A and D which mention a unified experience of human consciousness are eliminated as they state the opposite point

Option-B is also eliminated as it refers to a common humanity.

Option-C is the correct answer as it describes the classic in identical terms to the passage. A classic is something that is 'exploring the new., going beyond the universal, the contemporary, and the notion of a unified human consciousness'

Hence option C is the correct answer.

## SLOT-1 DILR

1. **Direction:** Read the information given below and answer the question that follows.

Healthy Bites is a fast food joint serving three items: burgers, fries, and ice cream. It has two employees Anish and Bani who prepare the items ordered by the clients. Preparation time is 10 minutes for a burger and 2 minutes for an order of ice cream. An employee can prepare only one of these items at a time. The fries are prepared in an automatic fryer which can prepare up to 3 portions of fries at a time, and takes 5 minutes irrespective of the number of portions. The fryer does not need an employee to constantly attend to it, and we can ignore the time taken by an employee to start and stop the fryer. Thus, an employee can be engaged in preparing other items while the frying is on. However, fries cannot be prepared in anticipation of future orders.

Healthy Bites wishes to serve the orders as early as possible. The individual items in any order are served as and when ready. However, the order is considered to be completely served only when all the items of that order are served.

The table below gives the orders of three clients and the times at which they placed their orders:

| Client No. | Time  | Order   |
|------------|-------|---|
| 1          | 10:00 | 1 burger, 3 portions of fries, 1 order of ice cream |
| 2          | 10:05 | 2 portions of fries, 1 order of ice cream           |
| 3          | 10:07 | 1 burger, 1 portion of fires                        |

Assume that only one client's order can be processed at any given point of time. So, Anish or Bani cannot start preparing a new order while a previous order is being prepared.

At what time is the order placed by Client 1 completely served?

- A. 10:17
- B. 10:10
- C. 10:15
- D. 10:20

Answer: B

Solution:

As the item which takes the maximum time is burger, i.e., 10 minutes, Client 1 will be served their entire order by 10:10.

2. Assume that only one client's order can be processed at any given point of time. So, Anish or Bani cannot start preparing a new order while a previous order is being prepared.

At what time is the order placed by Client 3 completely served?

- A. 10:35
- B. 10:22
- C. 10:25
- D. 10:17

Answer: C

Solution:

The time taken to prepare the orders for the different clients are

Client no: 1 – 10.00 – 10.10 (burger- 10 mins)

Client no: 2 – 10.10 – 10.15 (fries – 5 mins)

Client no: 3 – 10.15 – 10.25 (burger – 10 mins)

3. Suppose the employees are allowed to process multiple orders at a time, but the preference would be to finish orders of clients who placed their orders earlier.

At what time is the order placed by Client 2 completely served?

- A. 10:10
- B. 10:12
- C. 10:15
- D. 10:17

Answer: A

Solution:

When they are allowed to process multiple orders, the time taken would be

Client no: 1 – 10.00 – 10.10 (Assume Anish prepared burger)

Client no: 2 – 10.05 – 10.10 (Bani prepared fries)

Client 2 will be served their entire order by 10:10.



4. Suppose the employees are allowed to process multiple orders at a time, but the preference would be to finish orders of clients who placed their orders earlier.

Also assume that the fourth client came in only at 10:35. Between 10:00 and 10:30, for how many minutes is exactly one of the employees idle?

- A. 7
- B. 10
- C. 15
- D. 23

Answer: B

Solution:

Anish prepares a burger for the first client which will be ready by 10:10.

Bani will serve ice-cream by 10:02.

She will be idle upto 10:05 (as the second order comes at 10:05).

Bani will be idle for 3 minutes.

Bani will prepare ice-cream (10:05 to 10:07) and after that from 10:07 to 10:17, she will prepare a burger for client 3.

From 10:10 to 10:17, Anish will be idle for 7 minutes.

After 10:17, both Anish and Bani will be idle upto 10:35 (till next order comes).

Hence, from 10:00 to 10:30, exactly one employee will be idle for 3 + 7, i.e., 10 minutes.

5.

|||Common|||

**Direction:** Study the table/s given below and answer the question that follows.

A study to look at the early teaming of rural kids was carried out in a number of villages spanning three states, chosen from the North East (NE), the West (W) and the South (S). 50 four-year old kids from each of the 150 villages from NE, 250 villages from W and 200 villages from S were included in the study. It was found that of the 30000 kids surveyed, 55% studied in primary schools run by the government (G), 37% in private schools (P) while the remaining 8% did not go to school (O).

The kids surveyed were further divided into two groups based on whether their mothers dropped out of school before completing primary education. The table below gives the number of kids in different types of schools for mothers who dropped out of school before completing primary education:

|       | G     | P    | O    | Total |
|-------|-------|------|------|-------|
| NE    | 4200  | 500  | 300  | 5000  |
| W     | 4200  | 1900 | 1200 | 7300  |
| S     | 5100  | 300  | 300  | 5700  |
| Total | 13500 | 2700 | 1800 | 18000 |

It is also known that:

- 1) In S, 60% of the surveyed kids were in G. Moreover, in S, all surveyed kids whose mothers had completed primary education were in school.
- 2) In NE, among the O kids, 50% had mothers who had dropped out before completing primary education.
- 3) The number of kids in G in NE was the same as the number of kids in G in W.

|||End|||

What percentage of kids from S were studying in P?

- A. 37%
- B. 6%
- C. 79%
- D. 56%

Answer: A

Solution:

From the given data, we get the following table:

|       | G           |           | P           |           | O           |           | Total |
|-------|-------------|-----------|-------------|-----------|-------------|-----------|-------|
|       | Dropped out | Completed | Dropped out | Completed | Dropped out | Completed |       |
| NE    | 4200        | 1050      | 500         | 1150      | 300         | 300       | 7500  |
| W     | 4200        | 1050      | 1900        | 3850      | 1200        | 300       | 12500 |
| S     | 5100        | 900       | 300         | 3400      | 300         | 0         | 10000 |
| Total | 13,500      | 3000      | 2700        | 8400      | 1800        | 600       | 30000 |

$300 + 3400 = 3700$  students from S were studying in P

Required percentage =  $\frac{3700}{10000} = 37\%$

6. Among the kids in W whose mothers had completed primary education, how many were not in school?

- A. 300
- B. 1200
- C. 1050
- D. 1500

Answer: A

Solution:

From the given data, we get the following table.

|       | G           |           | P           |           | O           |           | Total |
|-------|-------------|-----------|-------------|-----------|-------------|-----------|-------|
|       | Dropped out | Completed | Dropped out | Completed | Dropped out | Completed |       |
| NE    | 4200        | 1050      | 500         | 1150      | 300         | 300       | 7500  |
| W     | 4200        | 1050      | 1900        | 3850      | 1200        | 300       | 12500 |
| S     | 5100        | 900       | 300         | 3400      | 300         | 0         | 10000 |
| Total | 13,500      | 3000      | 2700        | 8400      | 1800        | 600       | 30000 |

In W, 300 kids whose mothers had completed primary education were not in school.

7. In a follow-up survey of the same kids two years later, it was found that all the kids were now in school. Of the kids who were not in school earlier, in one region, 25% were in G now, whereas the rest were enrolled in P; in the second region, all such kids were in G now; while in the third region, 50% of such kids had now joined G while the rest had joined P. As a result, in all three regions put together, 50% of the kids who were earlier out of school had joined G. It was also seen that no surveyed kid had changed schools.

What number of the surveyed kids now were in G in W?

- A. 6000
- B. 5250
- C. 6750
- D. 6300

Answer: A

Solution:

From the given data, we get the following table:

|       | G           |           | P           |           | O           |           | Total |
|-------|-------------|-----------|-------------|-----------|-------------|-----------|-------|
|       | Dropped out | Completed | Dropped out | Completed | Dropped out | Completed |       |
| NE    | 4200        | 1050      | 500         | 1150      | 300         | 300       | 7500  |
| W     | 4200        | 1050      | 1900        | 3850      | 1200        | 300       | 12500 |
| S     | 5100        | 900       | 300         | 3400      | 300         | 0         | 10000 |
| Total | 13,500      | 3000      | 2700        | 8400      | 1800        | 600       | 30000 |

2400 students who were not in school and now 1200 of them are in G.

Therefore, 50% of W = 50% of 1500 = 750

25% of NE = 25% of 600 = 150

100% of S = 100% of 300 = 300

Total = 750 + 150 + 300 = 1200

Therefore, 4200 + 1050 + 750 = 6000 students were in G in W.

8. In a follow-up survey of the same kids two years later, it was found that all the kids were now in school. Of the kids who were not in school earlier, in one region, 25% were in G now, whereas the rest were enrolled in P; in the second region, all such kids were in G now; while in the third region, 50% of such kids had now joined G while the rest had joined P. As a result, in all three regions put together, 50% of the kids who were earlier out of school had joined G. It was also seen that no surveyed kid had changed schools.

What percentage of the surveyed kids in S, whose mothers had dropped out before completing primary education, were in G now?

- A. 94.7%
- B. 89.5%
- C. 93.4%
- D. Cannot be determined from the given information

Answer: A

Solution:

From the given data, we get the following table.

|       | G           |           | P           |           | O           |           | Total |
|-------|-------------|-----------|-------------|-----------|-------------|-----------|-------|
|       | Dropped out | Completed | Dropped out | Completed | Dropped out | Completed |       |
| NE    | 4200        | 1050      | 500         | 1150      | 300         | 300       | 7500  |
| W     | 4200        | 1050      | 1900        | 3850      | 1200        | 300       | 12500 |
| S     | 5100        | 900       | 300         | 3400      | 300         | 0         | 10000 |
| Total | 13,500      | 3000      | 2700        | 8400      | 1800        | 600       | 30000 |

All 300 in S who were not going to school, now shifted to G (from the previous question).

5700 students' mothers had dropped out in S regions.

Hence, 5400 are in G.

9.

|||Common|||

**Direction:** Read the information given below and answer the question that follows. Applicants for the doctoral programmes of Ambi Institute of Engineering (AIE) and Bambi Institute of Engineering (BIE) have to appear for a Common Entrance Test (CET). The test has three sections: Physics (P), Chemistry (C), and Maths (M). Among those appearing for CET, those at or above the 80th percentile in at least two sections, and at or above the 90th percentile overall, are selected for the Advanced Entrance Test (AET) conducted by AIE. AET is used by AIE for final selection.

For the 200 candidates who are at or above the 90th percentile overall based on CET, the following are known about their performance in CET:

- 1) No one is below the 80th percentile in all 3 sections.
  - 2) 150 are at or above the 80th percentile in exactly two sections.
  - 3) The number of candidates at or above the 80th percentile only in P is the same as the number of candidates at or above the 80th percentile only in C. The same is the number of candidates at or above the 80th percentile only in M.
  - 4) Number of candidates below 80th percentile in P : Number of candidates below 80th percentile in C : Number of candidates below 80th percentile in M = 4 : 2 : 1
- BIE uses a different process for selection. If any candidate is appearing in the AET by AIE, BIE considers their AET score for final selection provided the candidate has scored 80 percentile or more in P. Any other candidate at or above the 80 percentile in P in CET, but who is not eligible for the AET, is required to appear in a separate test to be conducted by BIE to be considered for final selection. Altogether, there are 400 candidates this year who have scored 80 percentile or more in P.

|||End|||

What best can be concluded about the number of candidates sitting for the separate test for BIE who were at or above the 90th percentile overall in CET?

- A. 3 or 10
- B. 10
- C. 5
- D. 7 or 10

Answer: A

Solution:

The Venn diagram shows the number of persons who scored above 80 percentile in CET in each of the three sections:

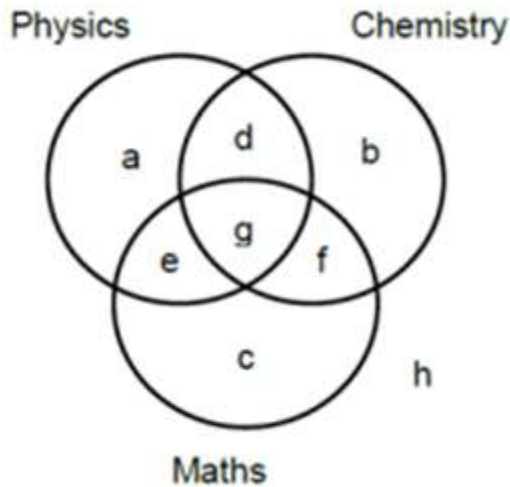

From 1,  $h = 0$ .

From 2,  $d + e + f = 150$ .

From 3,  $a = b = c$ .

We know that  $3a + g = 200 - 150 = 50$

From 4,  $(2a + f) : (2a + e) : (2a + d) = 4 : 2 : 1$

Hence,  $6a + (d + e + f)$  is a multiple of 7.

$d + e + f = 150$ ,  $6a + 150$  is a multiple of 7,

i.e.,  $6a + 3$  is a multiple of 7.

i.e.,  $6a + 3$  is a multiple of 7 (as 147 is a multiple of 7).

Hence,  $a = 3, 10, 17, \dots$

$3a + g = 50$

$a = 3$  or  $10$

We can calculate the values of the other variables for the two cases.

$a = 3, d = 18, e = 42, f = 90, g = 41$

$a = 10, d = 10, e = 40, f = 100, g = 20$

The candidates represented by  $d, e, f$  and  $g$  are selected for AET. Because, from the candidates who are at or above 90th percentile, the candidates who are at or above 80th percentile in at least two sections are selected for AET.

BIE will consider the candidates represented by  $d, e$  and  $g$ , which can be either 80 or 104.

BIE will conduct a separate test for the other students who are at or above 80th percentile in P.

Out of them some have an overall percentile of  $>90$  which is represented by  $a$ , i.e., 3 or 10.

10. If the number of candidates who are at or above the 90th percentile overall and also at or above the 80th percentile in all three sections in CET is actually a multiple of 5, what is the number of candidates who are at or above 90 percentile overall and at or above the 80 percentile in both P and M in CET?



Answer: 60

Solution:

The Venn diagram shows the number of persons who scored above 80 percentile in CET in each of the three sections:

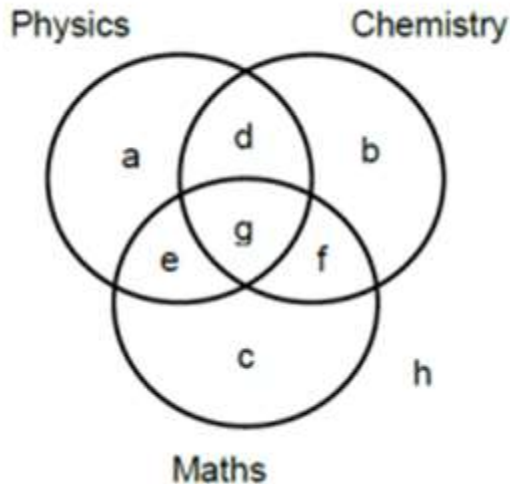

From 1,  $h = 0$

From 2,  $d + e + f = 150$

From 3,  $a = b = c$

we know that,  $3a + g = 200 - 150 = 50$

From 4,  $(2a + f) : (2a + e) : (2a + d) = 4 : 2 : 1$

Hence,  $6a + (d + e + f)$  is a multiple of 7.

$d + e + f = 150$ ,  $6a + 150$  is a multiple of 7,

i.e.,  $6a + 3$  is a multiple of 7,

i.e.,  $6a + 3$  is a multiple of 7 (as 147 is a multiple of 7).

Hence,  $a = 3, 10, 17, \dots$

$3a + g = 50$

$a = 3$  or  $10$

We can calculate the values of the other variables for the two cases.

$a = 3, d = 18, e = 42, f = 90, g = 41$

$a = 10, d = 10, e = 40, f = 100, g = 20$

We know that  $g$  is a multiple of 5, i.e.,  $g = 20$ .

The number of candidates who scored 90 percentile or more overall and those who scored 80 percentile or more in both P and M =  $g + e = 60$ .

11. If the number of candidates who have scored 90 percentile or more overall and also those who have scored 80 percentile or more in all three sections in CET is actually a multiple of 5, then how many candidates were shortlisted for the AET for AIE?

Answer: 170

Solution:

The Venn diagram shows the number of persons who scored above 80 percentile in CET in each of the three sections:

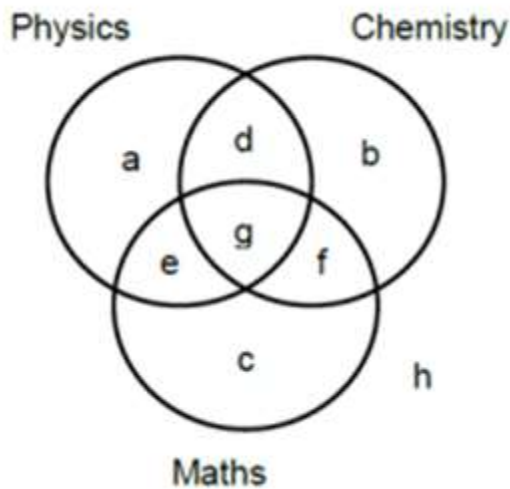

From 1,  $h = 0$ .

From 2,  $d + e + f = 150$

From 3,  $a = b = c$

We know that,  $3a + g = 200 - 150 = 50$

From 4,  $(2a + f) : (2a + e) : (2a + d) = 4 : 2 : 1$

Hence,  $6a + (d + e + f)$  is a multiple of 7

$d + e + f = 150$ ,  $6a + 150$  is a multiple of 7,

i.e.,  $6a + 3$  is a multiple of 7.

i.e.,  $6a + 3$  is a multiple of 7 (as 147 is a multiple of 7).

Hence,  $a = 3, 10, 17, \dots$

$3a + g = 50$ .

$a = 3$  or  $10$ .

We can calculate the values of the other variables for the two cases.

$a = 3, d = 18, e = 42, f = 90, g = 41$

$a = 10, d = 10, e = 40, f = 100, g = 20$

The candidates represented by  $d, e, f,$  and  $g$  are selected for AET. Because, from the candidates who have scored 90 percentile or more, the candidates who have scored 80 percentile or more in at least two sections are selected for AET.

Here,  $g = 20$ .

Number of candidates shortlisted for AET =  $d + e + f + g = 10 + 40 + 100 + 20 = 170$

12. If the number of candidates who score 90 percentile or more overall and also those who score 80 percentile or more in P in CET is more than 100, then how many candidates had to sit for the separate test for BIE?

- A. 299
- B. 310
- C. 321
- D. 330

Answer: A

Solution:

The Venn diagram shows the number of persons who scored above 80 percentile in CET in each of the three sections:

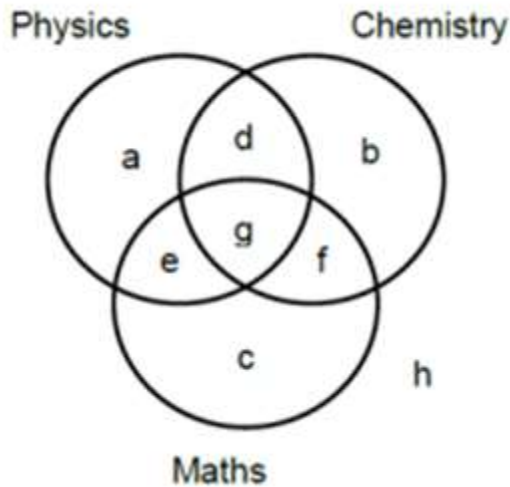

From 1,  $h = 0$

From 2,  $d + e + f = 150$

From 3,  $a = b = c$

we know that,  $3a + g = 200 - 150 = 50$

From 4,  $(2a + f):(2a + e):(2a + d) = 4:2:1$

Hence,  $6a + (d + e + f)$  is a multiple of 7.

$d + e + f = 150$ ,  $6a + 150$  is a multiple of 7,

i.e.,  $6a + 3$  is a multiple of 7,

i.e.,  $6a + 3$  is a multiple of 7 (as 147 is a multiple of 7).

Hence,  $a = 3, 10, 17, \dots$

$3a + g = 50$

$a = 3$  or  $10$

We can calculate the values of the other variables for the two cases.

$a = 3, d = 18, e = 42, f = 90, g = 41$

$a = 10, d = 10, e = 40, f = 100, g = 20$

So, the total number of students who got 80 percentile or more in P and also 90 percentile or more overall in CET =  $a + d + e + g = 80$  or  $104$ . Since the value is  $> 100$ , it has to be  $104$ .

$a = 3, d = 18, e = 42, f = 90, g = 41$

Number of students in separate test = Total students who got 80 percentile or more in P – the number of students who got 80 percentile or more in P and also qualified for AET

$$= 400 - (d + e + g)$$

$$= 400 - (18 + 42 + 41)$$

$$= 299$$

13.

|||Common|||

**Direction:** Analyse the graphs given below and answer the question that follows.

Simple Happiness Index (SHI) of a country is computed on the basis of three parameters: social support (S), freedom to life choices (F), and corruption perception (C). Each of these three parameters is measured on a scale of 0 to 8 (integers only). A country is then categorized based on the total score obtained by summing the scores of all the three parameters, as shown in the following table:

| Total Score | 0-4          | 5-8     | 9-13    | 14-19 | 20-24      |
|-------------|--------------|---------|---------|-------|------------|
| Category    | Very Unhappy | Unhappy | Neutral | Happy | Very Happy |

The following diagram depicts the frequency distribution of the scores in S, F, and C of 10 countries: Amda, Benga, Calla, Delma, Eppa, Varsa, Wanna, Xanda, Yanga and Zoorna.

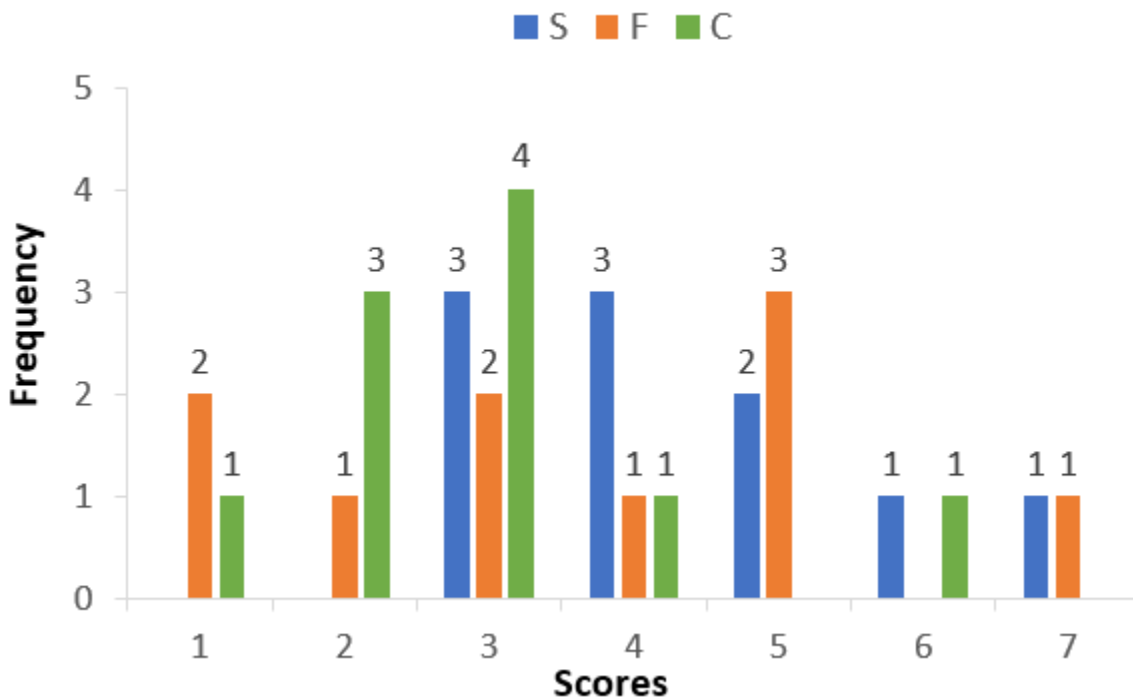

Further, the following are known:

- 1) Amda and Calls jointly have the lowest total score, 7, with identical scores in all the three parameters.
- 2) Zoorna has a total score of 17.
- 3) All the 3 countries, which are categorised as happy, have the highest score in exactly one parameter.

|||End|||

What is Amda's score in F?

Answer: 1

Solution:

The given data can be represented in a table as follows.

| Scores | S  | F  | C  |
|--------|----|----|----|
| 1      |    | 2  | 1  |
| 2      |    | 1  | 3  |
| 3      | 3  | 2  | 4  |
| 4      | 3  | 1  | 1  |
| 5      | 2  | 3  |    |
| 6      | 1  |    | 1  |
| 7      | 1  | 1  |    |
| Total  | 10 | 10 | 10 |

Amda and Calla had a total score of 7, with identical scores in all these parameters. The possibilities are 1, 2, and 4 or 3, 3, and 1.

Zooma's score = 17

All three countries in the happy category had the highest score in exactly one parameter.

Zooma can only have a 7 in F, 6 in S, and 4 in C as a score of 7 in S and 6 in C would be the scores of the other two countries.

Zooma cannot have a 7, 7, and 5 as there is no country which scored a 5 in C.

Amda can have a distribution of 3, 3, 1 or 4, 2, 1.

In either case, the only possible score of F is 1.

14. What is Zooma's score in S?

Answer: 6

Solution:

The given data can be represented in a table as follows.

| Scores | S  | F  | C  |
|--------|----|----|----|
| 1      |    | 2  | 1  |
| 2      |    | 1  | 3  |
| 3      | 3  | 2  | 4  |
| 4      | 3  | 1  | 1  |
| 5      | 2  | 3  |    |
| 6      | 1  |    | 1  |
| 7      | 1  | 1  |    |
| Total  | 10 | 10 | 10 |

Amda and Calla had a total score of 7, with identical scores in all these parameters. The possibilities are 1, 2, and 4 or 3, 3, and 1.

Zooma's score = 17

All three countries in the happy category had the highest score in exactly one parameter.

Zooma can only have a 7 in F, 6 in S, and 4 in C as a score of 7 in S and 6 in C would be the scores of the other two countries.

Zooma cannot have a 7, 7, and 5 as there is no country which scored a 5 in C.

Hence, Zooma's score in S has to be 6.

15. Benga and Delma, two countries categorized as happy, are tied with the same total score. What is the maximum score they can have?

- A. 14
- B. 15
- C. 16
- D. 17

Answer: B

Solution:

The given data can be represented in a table as follows.

| Scores | S  | F  | C  |
|--------|----|----|----|
| 1      |    | 2  | 1  |
| 2      |    | 1  | 3  |
| 3      | 3  | 2  | 4  |
| 4      | 3  | 1  | 1  |
| 5      | 2  | 3  |    |
| 6      | 1  |    | 1  |
| 7      | 1  | 1  |    |
| Total  | 10 | 10 | 10 |

Amda and Calla had a total score of 7, with identical scores in all these parameters. The possibilities are 1, 2, and 4 or 3, 3, and 1.

Zooma's score = 17

All three countries in the happy category had the highest score in exactly one parameter.

Zooma can only have a 7 in F, 6 in S, and 4 in C as a score of 7 in S and 6 in C would be the scores of the other two countries.

Zooma cannot have a 7, 7 and 5 as there is no country which scored a 5 in C.

In the table given, among the highest scores, a score of 7 in F, 6 in S, and 4 in S were the scores of Zooma.

The best possible scores remaining for Benga and Dalma would be

| Benga | Dalma |
|-------|-------|
| S - 5 | S - 7 |
| C - 6 | C - 3 |
| F - 5 | F - 5 |
| 16    | 15    |

As it is given that both had the same total score, it can only be 15. Hence, Benga's score in S or F was one less than the maximum possible score.

16. If Benga scores 16 and Delma scores 15, then what is the maximum number of countries with a score of 13?

- A. 0
- B. 1
- C. 2
- D. 3

Answer: B

Solution:

The given data can be represented in a table as follows.

| Scores | S  | F  | C  |
|--------|----|----|----|
| 1      |    | 2  | 1  |
| 2      |    | 1  | 3  |
| 3      | 3  | 2  | 4  |
| 4      | 3  | 1  | 1  |
| 5      | 2  | 3  |    |
| 6      | 1  |    | 1  |
| 7      | 1  | 1  |    |
| Total  | 10 | 10 | 10 |



Amda and Calla had a total score of 7, with identical scores in all these parameters. The possibilities are 1, 2 and 4 or 3, 3 and 1.

Zooma's score = 17.

All three countries in the happy category had the highest score in exactly one parameter.

Zooma can only have a 7 in F, 6 in S, and 4 in C as a score of 7 in S and 6 in C would be the scores of the other two countries.

Zooma cannot have a 7, 7, and 5 as there is no country which scored a 5 in C.

Considering the score of Zooma, Benga and Delma as 17, 16 and 15, we get

|       | S | F | C | Total |
|-------|---|---|---|-------|
| Zoom  | 6 | 7 | 4 | 17    |
| Benga | 5 | 5 | 6 | 16    |
| Delma | 7 | 5 | 3 | 15    |

In the table given, among the highest scores, a score of 7 in F, 6 in S, and 4 in S were the scores of Zooma.

The best possible scores remaining for Benga and Dalma would be

| Benga | Dalma |
|-------|-------|
| S - 5 | S - 7 |
| C - 6 | C - 3 |
| F - 5 | F - 5 |
| 16    | 15    |

If Benga's score is 16 and Dalma's score is 15, the maximum possible values remaining are

| Score | S | F | C |
|-------|---|---|---|
| 3     | 3 | 2 | 3 |
| 4     | 3 | 1 | 0 |
| 5     | 1 | 1 | 0 |

From the above table, the score of 13 can be for only one city.

17.

|||Common|||

**Direction:** Read the information given below and answer the question that follows. There are 21 employees working in a division, out of whom 10 are special-skilled employees (SE) and the remaining are regular-skilled employees (RE). During the next five months, the division has to complete five projects every month. Out of the 25 projects, 5 projects are "challenging", while the remaining ones are "standard". Each of the challenging projects has to be completed in different months. Every month, five teams - T1, T2, T3, T4 and T5, work on one project each. T1, T2, T3, T4 and T5 are allotted the challenging project in the first, second, third, fourth and fifth month, respectively. The team assigned the challenging project has one more employee than the rest.

In the first month, T1 has one more SE than T2, T2 has one more SE than T3, T3 has one more SE than T4, and T4 has one more SE than T5. Between two successive months, the composition of the teams changes as follows:

a. The team allotted the challenging project gets two SEs from the team which was allotted the challenging project in the previous month. In exchange, one RE is shifted from the former team to the latter team.

b. After the above exchange, if T1 has any SE and T5 has any RE, then one SE is shifted from T1 to T5, and one RE is shifted from T 5 to T1. Also, if T2 has any SE and T4 has any RE, then one SE is shifted from T2 to T4, and one RE is shifted from T 4 to T2.

Each standard project has a total of 100 credit points, while each challenging project has 200 credit points. The credit points are equally shared between the employees included in that team.

|||End|||

The number of times in which the composition of team T2 and the number of times in which composition of team T4 remained unchanged in two successive months are:

- A. (2, 1)
- B. (1, 0)
- C. (0, 0)
- D. (1, 1)

Answer: B

Solution:

Given that there are 10 SEs and 11 REs.

The number of SEs in T1, T2, T3, T4, and T5 must be 4, 3, 2, 1, and 0, respectively. The team that is assigned the challenging project will have 5 employees while the other teams will have 4 employees.

T1 is assigned the challenging project in the first month. Hence, T1 will have 5 employees, and the other teams will have 4 employees each.

The following table provides the composition of the teams in the first month:

| Team | SE | RE | Total |
|------|----|----|-------|
| T1   | 4  | 1  | 5     |
| T2   | 3  | 1  | 4     |
| T3   | 2  | 2  | 4     |
| T4   | 1  | 3  | 4     |
| T5   | 0  | 4  | 4     |

In the second month, T2 will be allotted the challenging project.

From a, two SEs will be shifted from T1 to T2. One RE is shifted from T2 to T1.

From b, one SE will be shifted from T1 to T5, one RE will be shifted from T5 to T1. Similar transfers will happen between T2 and T4.

The following table provides the number of employees in each team in the second month:

| Team | SE | RE | Total |
|------|----|----|-------|
| T1   | 1  | 3  | 4     |
| T2   | 4  | 1  | 5     |
| T3   | 2  | 2  | 4     |
| T4   | 2  | 2  | 4     |
| T5   | 1  | 3  | 4     |

In the third month, T3 will be allotted the challenging project.

From a, two SEs will be shifted from T2 to T3. One RE is shifted from T3 to T2.

From b, one SE will be shifted from T1 to T5, one RE will be shifted from T5 to T1.

And one SE will be shifted from T2 to T4 and one RE will be shifted from T4 to T2.

The following table provides the number of employees in each team in the third month:

| Team | SE | RE | Total |
|------|----|----|-------|
| T1   | 0  | 4  | 4     |
| T2   | 1  | 3  | 4     |
| T3   | 4  | 1  | 5     |
| T4   | 3  | 1  | 4     |
| T5   | 2  | 2  | 4     |

In the fourth month, T4 will be allotted the challenging project. From a, two SEs will be shifted from T3 to T4. One RE is shifted from T4 to T3. From b, one SE must be shifted from T1 to T5. There are no SEs in T1. Hence, this will not happen. One SE must be shifted from T2 to T4 and one RE must be shifted from T4 to T2. There are no REs in T4. Hence, this shifting will also not happen.

| Team | SE | RE | Total |
|------|----|----|-------|
| T1   | 0  | 4  | 4     |
| T2   | 1  | 3  | 4     |
| T3   | 2  | 2  | 4     |
| T4   | 5  | 0  | 5     |
| T5   | 2  | 2  | 4     |

In the fifth month, T5 will be allotted the challenging project. From a, two SEs will be shifted from T4 to T5. One RE is shifted from T5 to T4. From b, one SE must be shifted from T1 to T5. There are no SEs in T1. Hence, this will not happen. Also, one SE will be shifted from T2 to T4 and one RE will be shifted from T4 to T2. The following table provides the number of employees in each team in the fifth month:

| Team | SE | RE | Total |
|------|----|----|-------|
| T1   | 0  | 4  | 4     |
| T2   | 0  | 4  | 4     |
| T3   | 2  | 2  | 4     |
| T4   | 4  | 0  | 4     |
| T5   | 4  | 1  | 5     |

The composition of T2 did not change once between the third and the fourth months and the composition of T4 changed between any two successive months. Hence, the number of times in which the composition of team T2 and the number of times in which composition of team T4 remained unchanged in two successive months are (1, 0).

18. The number of SE in T1 and T5 for the projects in the third month are, respectively,:

- A. (0, 2).
- B. (0, 3).
- C. (1, 2).
- D. (1, 3).

Answer: A

Solution:

Given that there are 10 SEs and 11 REs.

The number of SEs in T1, T2, T3, T4, and T5 must be 4, 3, 2, 1, and 0.

The team that is assigned the challenging project will have 5 employees while the other teams will have 4 employees.

T1 is assigned the challenging project in the first month. Hence, T1 will have 5 employees and the other teams will have 4 employees each.

The following table provides the composition of the teams in the first month:

| Team | SE | RE | Total |
|------|----|----|-------|
| T1   | 4  | 1  | 5     |
| T2   | 3  | 1  | 4     |
| T3   | 2  | 2  | 4     |
| T4   | 1  | 3  | 4     |
| T5   | 0  | 4  | 4     |

In the second month, T2 will be allotted the challenging project.

From a, two SEs will be shifted from T1 to T2. One RE is shifted from T2 to T1.

From b, one SE will be shifted from T1 to T5, one RE will be shifted from T5 to T1. Similar transfers will happen between T2 and T4.

The following table provides the number of employees in each team in the second month:

| Team | SE | RE | Total |
|------|----|----|-------|
| T1   | 1  | 3  | 4     |
| T2   | 4  | 1  | 5     |
| T3   | 2  | 2  | 4     |
| T4   | 2  | 2  | 4     |
| T5   | 1  | 3  | 4     |

In the third month, T3 will be allotted the challenging project.

From a, two SEs will be shifted from T2 to T3. One RE is shifted from T3 to T2.

From b, one SE will be shifted from T1 to T5, one RE will be shifted from T5 to T1.

And one SE will be shifted from T2 to T4 and one RE will be shifted from T4 to T2.

The following table provides the number of employees in each team in the third month:

| Team | SE | RE | Total |
|------|----|----|-------|
| T1   | 0  | 4  | 4     |
| T2   | 1  | 3  | 4     |
| T3   | 4  | 1  | 5     |
| T4   | 3  | 1  | 4     |
| T5   | 2  | 2  | 4     |

In the fourth month, T4 will be allotted the challenging project.

From a, two SEs will be shifted from T3 to T4. One RE is shifted from T4 to T3.

From b, one SE must be shifted from T1 to T5. There are no SEs in T1. Hence, this will not happen.

One SE must be shifted from T2 to T4 and one RE must be shifted from T4 to T2. There are no REs in T4. Hence, this transfer will also not happen.

| Team | SE | RE | Total |
|------|----|----|-------|
| T1   | 0  | 4  | 4     |
| T2   | 1  | 3  | 4     |
| T3   | 2  | 2  | 4     |
| T4   | 5  | 0  | 5     |
| T5   | 2  | 2  | 4     |

In the fifth month, T5 will be allotted the challenging project.

From a, two SEs will be shifted from T4 to T5. One RE is shifted from T5 to T4.

From b, one SE must be shifted from T1 to T5. There are no SEs in T1, hence, this will not happen.

Also, one SE will be shifted from T2 to T4 and one RE will be shifted from T4 to T2.

The following table provides the number of employees in each team in the fifth month:

| Team | SE | RE | Total |
|------|----|----|-------|
| T1   | 0  | 4  | 4     |
| T2   | 0  | 4  | 4     |
| T3   | 2  | 2  | 4     |
| T4   | 4  | 0  | 4     |
| T5   | 4  | 1  | 5     |

Hence, the number of SE in T1 and T5 for the projects in the third month are 0, 2, respectively.

19. Which of the following CANNOT be the total credit points earned by any employee from the projects?

- A. 140
- B. 150
- C. 170
- D. 200

Answer: B

Solution:

Given that there are 10 SEs and 11 REs.

The number of SEs in T1, T2, T3, T4, and T5 must be 4, 3, 2, 1, and 0.

The team that is assigned the challenging project will have 5 employees, while the other teams will have 4 employees.

T1 is assigned the challenging project in the first month. Hence, T1 will have 5 employees, and the other teams will have 4 employees each.

The following table provides the composition of the teams in the first month:

| Team | SE | RE | Total |
|------|----|----|-------|
| T1   | 4  | 1  | 5     |
| T2   | 3  | 1  | 4     |
| T3   | 2  | 2  | 4     |
| T4   | 1  | 3  | 4     |
| T5   | 0  | 4  | 4     |

In the second month, T2 will be allotted the challenging project.

From a, two SEs will be shifted from T1 to T2. One RE is shifted from T2 to T1.

From b, one SE will be shifted from T1 to T5, one RE will be shifted from T5 to T1. Similar transfers will happen between T2 and T4.

The following table provides the number of employees in each team in the second month:

| Team | SE | RE | Total |
|------|----|----|-------|
| T1   | 1  | 3  | 4     |
| T2   | 4  | 1  | 5     |
| T3   | 2  | 2  | 4     |
| T4   | 2  | 2  | 4     |
| T5   | 1  | 3  | 4     |

In the third month, T3 will be allotted the challenging project.

From a, two SEs will be shifted from T2 to T3. One RE is shifted from T3 to T2.

From b, one SE will be shifted from T1 to T5, one RE will be shifted from T5 to T1.

And one SE will be shifted from T2 to T4 and one RE will be shifted from T4 to T2.

The following table provides the number of employees in each team in the third month:

| Team | SE | RE | Total |
|------|----|----|-------|
| T1   | 0  | 4  | 4     |
| T2   | 1  | 3  | 4     |
| T3   | 4  | 1  | 5     |
| T4   | 3  | 1  | 4     |
| T5   | 2  | 2  | 4     |

In the fourth month, T4 will be allotted the challenging project.

From a, two SEs will be shifted from T3 to T4. One RE is shifted from T4 to T3.

From b, one SE must be shifted from T1 to T5. There are no SEs in T1. Hence, this will not happen.

One SE must be shifted from T2 to T4 and one RE must be shifted from T4 to T2. There are no REs in T4. Hence, this transfer will also not happen.



| Team | SE | RE | Total |
|------|----|----|-------|
| T1   | 0  | 4  | 4     |
| T2   | 1  | 3  | 4     |
| T3   | 2  | 2  | 4     |
| T4   | 5  | 0  | 5     |
| T5   | 2  | 2  | 4     |

In the fifth month, T5 will be allotted the challenging project. From a, two SEs will be shifted from T4 to T5. One RE is shifted from T5 to T4. From b, one SE must be shifted from T1 to T5. There are no SEs in T1. Hence, this will not happen. Also, one SE will be shifted from T2 to T4 and one RE will be shifted from T4 to T2. The following table provides the number of employees in each team in the fifth month:

| Team | SE | RE | Total |
|------|----|----|-------|
| T1   | 0  | 4  | 4     |
| T2   | 0  | 4  | 4     |
| T3   | 2  | 2  | 4     |
| T4   | 4  | 0  | 4     |
| T5   | 4  | 1  | 5     |

Credits for the challenging projects = 200 credits and for the standard projects = 100 credits.

In each type of project, the credits are equally shared by the employees in the team. Hence, for a challenging project, an employee earns  $200/5 = 40$  credits.

For a standard project, an employee earns  $100/4 = 25$  credits.

The number of challenging and standard projects an employee can work on are (5,0) or (4,1) or (3,2) or (2,3) or (1,4) or (0,5).

In each case, an employee will earn 200 or 185 or 170 or 155 or 140 or 125 credits. Hence, it is impossible for an employee to earn 150 credits.

20. One of the employees named Aneek scored 185 points. Which of the following CANNOT be true?

- A. Aneek worked only in Teams T1, T2, T3, T4
- B. Aneek worked only in Teams T1, T2, T4, T5
- C. Aneek worked only in Teams T2, T3, T4, T5
- D. Aneek worked only in Teams T1, T3, T4, T5

Answer: D

Solution:

Given that there are 10 SEs and 11 REs.

The number of SEs in T1, T2, T3, T4, and T5 must be 4, 3, 2, 1, and 0.

The team that is assigned the challenging project will have 5 employees, while the other teams will have 4 employees.

T1 is assigned the challenging project in the first month. Hence, T1 will have 5 employees, and the other teams will have 4 employees each.

The following table provides the composition of the teams in the first month:

| Team | SE | RE | Total |
|------|----|----|-------|
| T1   | 4  | 1  | 5     |
| T2   | 3  | 1  | 4     |
| T3   | 2  | 2  | 4     |
| T4   | 1  | 3  | 4     |
| T5   | 0  | 4  | 4     |

In the second month, T2 will be allotted the challenging project.

From a, two SEs will be shifted from T1 to T2. One RE is shifted from T2 to T1.

From b, one SE will be shifted from T1 to T5, one RE will be shifted from T5 to T1. Similar transfers will happen between T2 and T4.

The following table provides the number of employees in each team in the second month:

| Team | SE | RE | Total |
|------|----|----|-------|
| T1   | 1  | 3  | 4     |
| T2   | 4  | 1  | 5     |
| T3   | 2  | 2  | 4     |
| T4   | 2  | 2  | 4     |
| T5   | 1  | 3  | 4     |

In the third month, T3 will be allotted the challenging project.

From a, two SEs will be shifted from T2 to T3. One RE is shifted from T3 to T2.

From b, one SE will be shifted from T1 to T5, one RE will be shifted from T5 to T1.

And one SE will be shifted from T2 to T4 and one RE will be shifted from T4 to T2.

The following table provides the number of employees in each team in the third month:

| Team | SE | RE | Total |
|------|----|----|-------|
| T1   | 0  | 4  | 4     |
| T2   | 1  | 3  | 4     |
| T3   | 4  | 1  | 5     |
| T4   | 3  | 1  | 4     |
| T5   | 2  | 2  | 4     |

In the fourth month, T4 will be allotted the challenging project.

From a, two SEs will be shifted from T3 to T4. One RE is shifted from T4 to T3.

From b, one SE must be shifted from T1 to T5. There are no SEs in T1. Hence, this will not happen.

One SE must be shifted from T2 to T4 and one RE must be shifted from T4 to T2.

There are no REs in T4. Hence, this transfer will also not happen.

| Team | SE | RE | Total |
|------|----|----|-------|
| T1   | 0  | 4  | 4     |
| T2   | 1  | 3  | 4     |
| T3   | 2  | 2  | 4     |
| T4   | 5  | 0  | 5     |
| T5   | 2  | 2  | 4     |

In the fifth month, T5 will be allotted the challenging project.

From a, two SEs will be shifted from T4 to T5. One RE is shifted from T5 to T4.

From b, one SE must be shifted from T1 to T5. There are no SEs in T1, hence, this will not happen.

Also, one SE will be shifted from T2 to T4 and one RE will be shifted from T4 to T2.

The following table provides the number of employees in each team in the fifth month:

| Team | SE | RE | Total |
|------|----|----|-------|
| T1   | 0  | 4  | 4     |
| T2   | 0  | 4  | 4     |
| T3   | 2  | 2  | 4     |
| T4   | 4  | 0  | 4     |
| T5   | 4  | 1  | 5     |

Since Aneek secured 185 credits, he worked in four challenging projects and one standard project.

Option A is possible:

|    | Month           | Project     |
|----|-----------------|-------------|
| T1 | 1 <sup>st</sup> | Challenging |
| T2 | 2 <sup>nd</sup> | Challenging |
| T3 | 3 <sup>rd</sup> | Challenging |
| T4 | 4 <sup>th</sup> | Challenging |
| T4 | 5 <sup>th</sup> | Standard    |

Option B is possible:

|    | Month           | Project     |
|----|-----------------|-------------|
| T1 | 1 <sup>st</sup> | Challenging |
| T2 | 2 <sup>nd</sup> | Challenging |
| T3 | 3 <sup>rd</sup> | Standard    |
| T4 | 4 <sup>th</sup> | Challenging |
| T5 | 5 <sup>th</sup> | Challenging |

Option C is possible:

|    | Month           | Project     |
|----|-----------------|-------------|
| T2 | 1 <sup>st</sup> | Standard    |
| T2 | 2 <sup>nd</sup> | Challenging |
| T3 | 3 <sup>rd</sup> | Challenging |
| T4 | 4 <sup>th</sup> | Challenging |
| T5 | 5 <sup>th</sup> | Challenging |

Option D is not possible:

|       |                 |             |
|-------|-----------------|-------------|
| T1    | 1 <sup>st</sup> | Challenging |
| T1/T5 | 2 <sup>nd</sup> | Challenging |

In this, he cannot work in T3 without working in T2 first. If we assume that he worked in T3 in the first month, he could not have worked in four teams in the five months. 21.

|||Common|||

**Direction:** Read the information given below and answer the question that follows. In a square layout of size 5m × 5m, 25 equal-sized square platforms of different heights are built. The heights (in metres) of individual platforms are as shown below:

|   |   |   |   |   |
|---|---|---|---|---|
| 6 | 1 | 2 | 4 | 3 |
| 9 | 5 | 3 | 2 | 8 |
| 7 | 8 | 4 | 6 | 5 |
| 3 | 9 | 5 | 1 | 2 |
| 1 | 7 | 6 | 3 | 9 |

Individuals (all of the same height) are seated on these platforms. We say an individual A can reach an individual B if all the three following conditions are met:

- (i) A and B are in the same row or column.
- (ii) A is at a lower height than B.
- (iii) If there is/are any individual(s) between A and B, such individual(s) must be at a height lower than that of A.

Thus, in the table given above, consider the individual seated at height 8 on the 3rd row and 2nd column. He can be reached by four individuals. He can be reached by the individual on his left at height 7, by the two individuals on his right at heights of 4 and 6 and by the individual above at height 5.

Rows in the layout are numbered from top to bottom and columns are numbered from left to right.

How many individuals in this layout can be reached by just one individual?

- A. 3
- B. 5
- C. 7
- D. 8

Answer: C

Solution:

The heights of the platforms given are as below.

|   |   |   |   |   |
|---|---|---|---|---|
| 6 | 1 | 2 | 4 | 3 |
| 9 | 5 | 3 | 2 | 8 |
| 7 | 8 | 4 | 6 | 5 |
| 3 | 9 | 5 | 1 | 2 |
| 1 | 7 | 6 | 3 | 9 |

The number of persons who can be reached by just one individual is highlighted.

|   |   |   |   |   |
|---|---|---|---|---|
| 6 | 1 | 2 | 4 | 3 |
| 9 | 5 | 3 | 2 | 8 |
| 7 | 8 | 4 | 6 | 5 |
| 3 | 9 | 5 | 1 | 2 |
| 1 | 7 | 6 | 3 | 9 |

A total of 7 persons can be reached by just one individual.

22. Which of the following is true for any individual at a platform of height 1 m in this layout?

- A. They can be reached by all the individuals in their own row and column.
- B. They can be reached by at least 4 individuals.
- C. They can be reached by at least one individual.
- D. They cannot be reached by anyone.

Answer: D

Solution:

The heights of the platforms given is as below.

|   |   |   |   |   |
|---|---|---|---|---|
| 6 | 1 | 2 | 4 | 3 |
| 9 | 5 | 3 | 2 | 8 |
| 7 | 8 | 4 | 6 | 5 |
| 3 | 9 | 5 | 1 | 2 |
| 1 | 7 | 6 | 3 | 9 |

For any individual at a platform of height 1 m in this layout, they cannot be reached by anyone.

23. We can find two individuals who cannot be reached by anyone in

- A. the last row.
- B. the fourth row.
- C. the fourth column.
- D. the middle column.

Answer: C

Solution:

The heights of the platforms given are as below.

|   |   |   |   |   |
|---|---|---|---|---|
| 6 | 1 | 2 | 4 | 3 |
| 9 | 5 | 3 | 2 | 8 |
| 7 | 8 | 4 | 6 | 5 |
| 3 | 9 | 5 | 1 | 2 |
| 1 | 7 | 6 | 3 | 9 |

In the fourth column, we can find the two individuals (height 2 and height 1) who cannot be reached by anyone.

24. Which of the following statements is true about this layout?

- A. Each row has an individual who can be reached by 5 or more individuals.
- B. Each row has an individual who cannot be reached by anyone.
- C. Each row has at least two individuals who can be reached by an equal number of individuals.
- D. All individuals at the height of 9 m can be reached by at least 5 individuals.

Answer: C

Solution:

The heights of the platforms given are as below.

|   |   |   |   |   |
|---|---|---|---|---|
| 6 | 1 | 2 | 4 | 3 |
| 9 | 5 | 3 | 2 | 8 |
| 7 | 8 | 4 | 6 | 5 |
| 3 | 9 | 5 | 1 | 2 |
| 1 | 7 | 6 | 3 | 9 |

No individual in row 1 can be reached by 5 or more individuals. Hence, I is wrong.

Row 3 has no individual who cannot be reached by anyone. Hence, II is wrong.

The individual at height 9 in column 1 can be reached by only 4 individuals. Hence, IV is wrong.

Each row has at least two individuals who can be reached by an equal number of individuals – This is correct.

∴ Only Statement - 3 is correct.

25.

|||Common|||

**Direction:** Read the information given below and answer the question that follows.

A new airlines company is planning to start operations in the country. The company has identified ten different cities which they plan to connect through their network to start with. The flight duration between any pair of cities will be less than one hour. To start operations, the company has to decide on a daily schedule.

The underlying principle that they are working on is the following:

Any person staying in any of these 10 cities should be able to make a trip to any other city in the morning and should be able to return by the evening of the same day.

|||End|||



If the underlying principle is to be satisfied in such a way that the journey between any two cities can be performed using only direct (non-stop) flights, then the minimum number of direct flights to be scheduled is:

- A. 45.
- B. 90.
- C. 180.
- D. 135.

Answer: C

Solution:

For any pair of cities, say P and Q, there must be a morning flight from P to Q, an evening flight from Q to P and a morning flight from Q to P and an evening flight from P to Q. Only then can a person from P or Q travel to Q or P and return the same day. Hence, there must be four flights between any pair of cities. Number of ways of selecting two cities from ten cities

$$= {}^{10}C_2 = (10 \times 9) / 2 = 45$$

Hence, the minimum number of flights that must be scheduled =  $4 \times 45 = 180$ .

26. Suppose three of the ten cities are to be developed as hubs. A hub is a city which is connected with every other city by direct flights each way, both in the morning as well as in the evening. The only direct flights which will be scheduled are originating and/or terminating in one of the hubs. Then the minimum number of direct flights that need to be scheduled so that the underlying principle of the airline to serve all the ten cities is met without visiting more than one hub during one trip is:

- A. 54.
- B. 120.
- C. 96.
- D. 60.

Answer: C

Solution:

Let the ten cities be represented by 1 through 10. Among these ten cities, consider 1, 2 and 3 to be hubs and the other seven cities to be non-hub cities. It is given that any direct flight should originate and/or terminate at a hub.

Consider city 4, which is not a hub. 4 should be connected to each of 1, 2 and 3.

Between 4 and each of 1, 2 and 3, there must be four flights .

Hence, from 4, there must be  $4 \times 3 = 12$  flights to the three hubs, 1, 2 and 3.

Similarly, for each of the other six non-hub cities, there must be 12 flights connecting each non-hub city with the three hubs.

Hence, a total of  $12 \times 7 = 84$  flights will connect a non-hub city with a hub.

The three hubs must be connected amongst themselves.

Since there must be four flights between any pair of cities, there must be a total of  $3 \times 4 = 12$  flights connecting any pair of hubs.

Hence, the total minimum number of flights that should be scheduled =  $84 + 12 = 96$

27. Suppose the 10 cities are divided into 4 distinct groups  $G_1, G_2, G_3, G_4$  having 3, 3, 2 and 2 cities respectively and that  $G_1$  consists of cities named A, B and C. Further, suppose that direct flights are allowed only between two cities satisfying one of the following:

- Both cities are in  $G_1$
- Between A and any city in  $G_2$
- Between B and any city in  $G_3$
- Between C and any city in  $G_4$

Then the minimum number of direct flights that satisfies the underlying principle of the airlines is

Answer: 40

Solution:

$G_2$  cannot be connected by a direct flight to a city in  $G_3$  or  $G_4$ .

For a person to travel from a city in  $G_2$  to a city in  $G_3$  or  $G_4$ , all the cities in  $G_2$  must be connected to A and from A, he can travel to B or C to travel to a city  $G_3$  or  $G_4$ , respectively.

Hence, A must be connected to the 3 cities in  $G_2$ .

Hence, there must be  $4 \times 3 = 12$  flights between cities in A and  $G_2$ .

There are 2 cities in  $G_3$  and  $G_4$  each. There must be  $2 \times 4 = 8$  flights between cities in  $G_3$  and B and between cities in  $G_4$  and C. A, B and C must be connected to each other. Hence, there are an additional 12 flights between these three cities.

The total minimum number of direct flights that must be scheduled =  $12 + 8 + 8 + 12 = 40$ .

28. Suppose the 10 cities are divided into 4 distinct groups  $G_1, G_2, G_3, G_4$  having 3, 3, 2 and 2 cities respectively and that  $G_1$  consists of cities named A, B and C. Further, suppose that direct flights are allowed only between two cities satisfying one of the following:

- Both cities are in  $G_1$
- Between A and any city in  $G_2$
- Between B and any city in  $G_3$
- Between C and any city in  $G_4$

However, due to operational difficulties at A, it was later decided that the only flights that would operate at A would be those to and from B. Cities in  $G_2$  would have to be assigned to  $G_3$  or to  $G_4$ .

What would be the maximum reduction in the number of direct flights as compared to the situation before the operational difficulties arose?

Answer: 4

Solution:

$G_2$  will be assigned to  $G_3$  or  $G_4$ . The cities in  $G_2$  will still have to be connected to either B or C.

There are no flights between A and C. Hence, 4 flights that would have been scheduled in the previous case, will now not be scheduled.

Hence, the maximum reduction in the number of direct flights as compared to the situation before the operational difficulties arose is 4.

29.

|||Common|||

**Direction:** Read the information given below and answer the question that follows. Four cars need to travel from Akala (A) to Bakala (B). Two routes are available, one via Mamur (M) and the other via Nanur (N). The roads from A to M, and from N to B, are both short and narrow. In each case, one car takes 6 minutes to cover the distance, and each additional car increases the travel time per car by 3 minutes because of congestion. (For example, if only two cars drive from A to M, each car takes 9 minutes.) On the road from A to N, one car takes 20 minutes, and each additional car increases the travel time per car by 1 minute. On the road from M to B, one car takes 20 minutes, and each additional car increases the travel time per car by 0.9 minute.

The police department orders each car to take a particular route in such a manner that it is not possible for any car to reduce its travel time by not following the order, while the other cars are following the order.

|||End|||

How many cars would be asked to take the route A-N-B, that is Akala-Nanur-Bakala route, by the police department?

Answer: 2

Solution:

There are four cars and two routes. Two cars should go through A-N-B and the other two through A-M-B. If one of them broke the rule, the travel time would increase. If 3 cars are allowed on the A-M-B route, one car can break the rule and reduce the travel time. Hence, 2 cars would be asked to take the route A-N-B

30. If all the cars follow the police order, what is the difference in travel time (in minutes) between a car which takes the route A-N-B and a car that takes the route A-M-B?

A. 1

B. 0.1

C. 0.2

D. 0.9

Answer: B

Solution:

2 cars are allowed through A - N - B and A - M - B.

Time taken through A - M - B = 29.9 minutes and through A - N - B = 30 minutes.

The required difference = 0.1 minutes

31. A new one-way road is built from M to N. Each car now has three possible routes to travel from A to B: A-M-B, A-N-B and A-M-N-B. On the road from M to N, one car takes 7 minutes and each additional car increases the travel time per car by 1 minute. Assume that any car taking the A-M-N-B route travels the A-M portion at the same time as other cars taking the A-M-B route, and the N-B portion at the same time as other cars taking the A-N-B route.

How many cars would the police department order to take the A-M-N-B route so that it is not possible for any car to reduce its travel time by not following the order while

the other cars follow the order? (Assume that the police department would never order all the cars to take the same route.)

Answer: 2

Solution:

Either two or three cars should go through A-M.

Case 1: 2 cars go through the M-B route.

One car can break the police order and go through M-N and reach B.

Time taken =  $9 + 7 + 12 = 28$  minutes

Case 2: Both went through the A-M-B route, time taken = 29.9 minutes.

Case 3: 2 cars go through A-M and one of them goes through M-N,

One of the cars that went through A-N can break the police order and had gone through A-M-B

Original time =  $21 + 12 = 33$  minutes.

Time saved =  $33 - \text{new time}$ , i.e.,  $33 - (12 + 20.9) = 33 - 32.9 = 0.1$  minute

Case 4: If both cars are directed to go through M-N, all four cars would go through N-B, which is not possible.

Case 5: If 3 cars are directed to go through A-M

either one or two cars can be directed through M-N.

Case 5a: If one car is directed through M-N

The car that was directed through M-B can break the police order and go through the M-N route.

Time saved =  $(12 + 20.9) - (12 + 8 + 12) = 0.9$  minutes

Hence, the police department ordered 2 cars to take the A-M-N-B route so that it is not possible for any car to reduce its travel time by not following the order while the other cars follow the order, two cars must be directed through M-N such that any car breaking the police order cannot reduce the travel time.

32. A new one-way road is built from M to N. Each car now has three possible routes to travel from A to B: A-M-B, A-N-B and A-M-N-B. On the road from M to N, one car takes 7 minutes and each additional car increases the travel time per car by 1 minute. Assume that any car taking the A-M-N-B route travels the A-M portion at the same time as other cars taking the A-M-B route, and the N-B portion at the same time as other cars taking the A-N-B route.

If all the cars follow the police order, what is the minimum travel time (in minutes) from A to B? (Assume that the police department would never order all the cars to take the same route.)

A. 26

B. 32

C. 29.9

D. 30

Answer: B

Solution:

When all cars follow the police order the time taken would be

One car - A-M-B =  $(6 + 3 \times 2) + 20 = 32$  minutes.

Two cars - A-M-N-B =  $(6 + 3 \times 2) + (7 + 1) + (6 + 3 \times 2) = 32$  minutes.

One car - A-N-B =  $20 + (6 + 3 \times 2) = 32$  minutes.

The minimum travel time from A to B is 32 minutes.

## SLOT-1 QA

1. Arun's present age in years is 40% of Barun's. In another few years, Arun's age will be half of Barun's. By what percentage will Barun's age increase during this period?

**Answer:** 20

**Solution:**

Let the present age of Barun be 100B years.

So, the present age of Arun = 40B years

Let after T years, Arun's age will be half of Barun's age.

So,  $2(40B + T) = 100B + T$

$80B + 2T = 100B + T$  or  $T = 20B$

So, Barun's age has increased by 20%.

Hence, 20 is the correct answer.

2. A person can complete a job in 120 days. He works alone on Day 1. On Day 2, he is joined by another person who also can complete the job in exactly 120 days. On Day 3, they are joined by another person of equal efficiency. Like this, everyday a new person with the same efficiency joins the work. How many days are required to complete the job?

**Answer:** 15

**Solution:**

Let a person do W work in a day.

Then, total work = 120W

We get the following table:

| Day number | Number of persons | Work today | Work till today |
|------------|-------------------|------------|-----------------|
| 1          | 1                 | W          | W               |
| 2          | 2                 | 2W         | 3W              |
| 3          | 3                 | 3W         | 6W              |
| 4          | 4                 | 4W         | 10W             |
| 5          | 5                 | 5W         | 15W             |
| 6          | 6                 | 6W         | 21W             |
| 7          | 7                 | 7W         | 28W             |
| N          | N                 | NW         | $NW(N+1)/2$     |

So, if  $\frac{NW(N+1)}{2} = 120W$

$N(N + 1) = 240$  or  $N = 15$

Hence, 15 is the correct answer.

3. An elevator has a weight limit of 630 kg. It is carrying a group of people of whom the heaviest weighs 57 kg and the lightest weighs 53 kg. What is the maximum possible number of people in the group?

**Answer:** 11

**Solution:**

To accommodate the maximum number of people, the weight of each person must be the least, that is 53kg.

The elevator has a weight limit of 630 kg and the heaviest person is 57 kg.

So, the remaining persons must weigh (630 – 57) kg at max or 573 kg at max

Now, the maximum number of persons =  $\frac{573}{53} = 10\frac{43}{53}$

So, the maximum number of persons weighing 53 kg each is 10 and there is another person who weighs 57 kgs.

Hence, the maximum number of persons in that elevator can be  $10 + 1 = 11$

Hence, 11 is the correct answer.

- 4. A man leaves his home and walks at a speed of 12 km per hour, reaching the railway station 10 minutes after the train had departed. If instead he had walked at a speed of 15 km per hour, he would have reached the station 10 minutes before the train's departure. The distance (in km) from his home to the railway station is:

**Answer:** 20

**Solution:**

Let the distance be  $60D$  km (LCM (12,15)).

We get the following table:

| Case  | Distance (km) | Speed (kmph) | Time (H) | Time (min)                  |
|-------|---------------|--------------|----------|-----------------------------|
| Exact | $60D$         | $S$          | $T$      | $60T$                       |
| Early | $60D$         | 12           | $5D$     | $300D = 60T + 10 \dots (1)$ |
| Late  | $60D$         | 15           | $4D$     | $240D = 60T - 10 \dots (2)$ |

From (1) - (2), we get,  $300D - 240D = 20$

$60D = 20$

Hence, 20 is the correct answer.

- 5. Ravi invests 50% of his monthly savings in fixed deposits. Thirty percent of the rest of his savings is invested in stocks and the rest goes into Ravi's savings bank account. If the total amount deposited by him in the bank (for savings account and fixed deposits) is Rs 59,500, then Ravi's total monthly savings (in Rs) is:

**Answer:** 70,000

**Solution:**

Let Ravi's savings =  $100S$

So, fixed deposit =  $50S$  and remaining =  $50S$

Stocks = 30% of  $50S = 15S$

So, savings bank =  $50S - 15S = 35S$

Total in bank = fixed + savings =  $50S + 35S = 85S = 59500$  or  $S = 700$

So, total savings =  $100S = 70,000$

Hence, 70,000 is the correct answer.

- 6. If a seller gives a discount of 15% on retail price, she still makes a profit of 2%. Which of the following ensures that she makes a profit of 20%?
  - A. Give a discount of 5% on retail price
  - B. Give a discount of 2% on retail price
  - C. Increase the retail price by 2%
  - D. Sell at retail price

**Answer: D**

**Solution:**

Let the cost price be  $100C$  and the marked price be  $100M$ .

So, selling price =  $100M - 15M = 85M$ , profit =  $2C$

So, selling price =  $100C + 2C = 102C = 85M$

$6C = 5M = 30K$  (let), where  $K$  is a non-zero constant.



C = 5K and M = 6K, cost price = 500K and selling price = 600K

As profit is 20%, profit = 100K.

Selling price = cost price + profit = 500K + 100K = 600K

So, there is no discount.

Hence, option (D) is the correct answer.

7. A man travels by a motor boat down a river to his office and back. With the speed of the river unchanged, if he doubles the speed of his motor boat, then his total travel time gets reduced by 75%. The ratio of the original speed of the motor boat to the speed of the river is:

- A.  $\sqrt{6}:\sqrt{2}$
- B.  $\sqrt{7}:2$
- C.  $2\sqrt{5}:3$
- D.  $3:2$

**Answer: B**

**Solution:**

Let the original speed of the motor boat be M units and the speed of the river be R units.

So, downstream speed = D = M + R and upstream speed = U = M - R

Let, the distance be A units.

So, time taken =  $\frac{A}{D} + \frac{A}{U} = A \left( \frac{1}{M+R} + \frac{1}{M-R} \right) = 4T(\text{let}) \dots \dots \dots (1)$

In the second case, M becomes 2M.

So, the time taken will be  $A \left( \frac{1}{2M+R} + \frac{1}{2M-R} \right) = T \dots \dots \dots (2)$

From (1) and (2), we get,  $A \left( \frac{1}{M+R} + \frac{1}{M-R} \right) = 4A \left( \frac{1}{2M+R} + \frac{1}{2M-R} \right)$

$$\left( \frac{1}{M+R} + \frac{1}{M-R} \right) = 4 \left( \frac{1}{2M+R} + \frac{1}{2M-R} \right)$$

$$\frac{2M}{M^2 - R^2} = \frac{16M}{4M^2 - R^2}$$

$(4M^2 - R^2) = 8(M^2 - R^2)$

$4M^2 - R^2 = 8M^2 - 8R^2$

$7R^2 = 4M^2$

$\frac{R^2}{M^2} = \frac{4}{7} = \left( \frac{2}{\sqrt{7}} \right)^2$

M:R =  $\sqrt{7}:2$

Hence, option (B) is the correct answer.

8. Suppose, C1, C2, C3, C4, and C5 are five companies. The profits made by C1, C2, and C3 are in the ratio 9:10:8 while the profits made by C2, C4, and C5 are in the ratio 18:19:20. If C5 has made a profit of Rs 19 crore more than C1, then the total profit (in Rs) made by all five companies is:

- A. 438 crore
- B. 435 crore
- C. 348 crore
- D. 345 crore

**Answer:** A

**Solution:**

The corresponding values for C2 are given as 10 and 18. LCM of which is 90.

On combining the ratios, we get C1:C2:C3:C4:C5 = 81:90:72:95:100

C1:C2:C3:C4:C5 = 81K:90K:72K:95K:100K, where K is a non-zero constant.

So,  $100K - 81K = 19K = 19$  crore (given)

$K = 1$  crore

Total profit =  $438k = 438$  crore

Hence, option (A) is the correct answer.

9. The number of girls appearing for an admission test is twice the number of boys. If 30% of the girls and 45% of the boys get admission, the percentage of candidates who do not get admission is:

- A. 35
- B. 50
- C. 60
- D. 65

**Answer:** D

**Solution:**

Let there be 100B boys and there are 200B girls.

Now, we get the following table:

|       | Admitted          | Rejected            | Total |
|-------|-------------------|---------------------|-------|
| Girls | 30% of 200B=60B   | $200B - 60B = 140B$ | 200B  |
| Boys  | 45% of 100B = 45B | $100B - 45B = 55B$  | 100B  |
| Total | 105B              | 195B                | 300B  |

So, rejected percentage =  $\frac{195}{300} \times 100\% = 65\%$

Hence, option (D) is the correct answer.

10. A stall sells popcorn and chips in packets of three sizes: large, super, and jumbo. The numbers of large, super, and jumbo packets in its stock are in the ratio 7:17:16 for popcorn and 6:15:14 for chips. If the total number of popcorn packets in its stock is the same as that of chips packets, then the numbers of jumbo popcorn packets and jumbo chips packets are in the ratio:

- A. 1:1
- B. 8:7
- C. 4:3
- D. 6:5

**Answer:** A

**Solution:**

|       | Popcorn | Chips |
|-------|---------|-------|
| Large | 7p      | 6c    |
| Super | 17p     | 15c   |
| Jumbo | 16p     | 14c   |
| Total | 40p     | 35c   |

Where p and c are non-zero constants.

$$\text{Since } 40p = 35c$$

$$8p = 7c = 56k \text{ (let)}$$

$$p = 7k \text{ and } c = 8k$$

$$\text{Required ratio} = 16p:14c = 16 \times 7k:14 \times 8k = 1:1$$

Hence, option (A) is the correct answer.

11. In a market, the price of medium quality mangoes is half that of good mangoes. A shopkeeper buys 80 kg good mangoes and 40 kg medium quality mangoes from the market and then sells all these at a common price which is 10% less than the price at which he bought the good ones. His overall profit is:

- A. 6%.
- B. 8%.
- C. 10%.
- D. 12%.

**Answer: B**

**Solution:**

Let the price of medium mangoes be Rs. 100P/kg.

So, the price of good mangoes = Rs. 200P/kg

$$\text{So, total cost price} = 80 \times 200P + 40 \times 100P = 20000P$$

$$\text{Total SP} = (200 - 10\%) P \times (80 + 40) = 180P \times 120 = 21600 P$$

So, there is profit of 1600P over 20000P.

$$\text{So, percentage} = \frac{1600P}{20000P} \times 100\% = 8\%$$

Hence, option (B) is the correct answer.

12. If Fatima sells 60 identical toys at a 40% discount on the printed price, then she makes 20% profit. Ten of these toys were destroyed in a fire. While selling the rest, how much discount should be given on the printed price so that she can make the same amount of profit?

- A. 30%
- B. 25%
- C. 24%
- D. 28%

**Answer: D**

**Solution:**

Let the printed price for each of the toys be Rs. 100P.

Discount for each toy = Rs 40P and selling price for each toy = Rs. 60P

$$\text{Profit} = 20\% \text{ of } 100C \text{ (assuming } 100C \text{ as the cost price of each toy)} = 20C$$

$$\text{So, SP} = 120C = 60P \text{ and } P = 2C \text{ or printed price} = 200C$$

Now, total cost of all 60 toys = 6000C

Destroyed in fire = 10 and remaining = 50

$$\text{Overall profit needed} = 20\% \text{ of } 6000C = 1200C$$

Overall selling price = 7200C

Selling price of each of the 50 good toys = 144C

So, discount = printed price – selling price = 200C – 144C = 56C

So, discount percentage = 28%

Hence, option (D) is the correct answer.

13. If a and b are integers of opposite signs such that  $(a + 3)^2:b^2 = 9:1$  and  $(a - 1)^2:(b - 1)^2 = 4:1$ , then the ratio  $a^2:b^2$  is:

- A. 9:4
- B. 81:4
- C. 1:4
- D. 25:4

**Answer:** D

**Solution:**

From the first equation, taking square roots of each side, we will get,

$(a+3):b = 3:1$  or  $-3:1$  .....(1)

Similarly the second equation, we get,  $(a-1):(b-1) = 2:1$  or  $-2:1$ .....(2)

So, we get four sets of equations which are as follows:

| Set | First equation    | Second equation      | Value of a | Value of b |
|-----|-------------------|----------------------|------------|------------|
| 1   | $(a+3):b = 3:1$   | $(a-1):(b-1) = 2:1$  | 3          | 2          |
| 2   | $(a+3) :b = -3:1$ | $(a-1):(b-1) = 2:1$  | -9/5       | -2/5       |
| 3   | $(a+3):b = 3:1$   | $(a-1):(b-1) = -2:1$ | 3/5        | 6/5        |
| 4   | $(a+3):b = -3:1$  | $(a-1):(b-1) = -2:1$ | 15         | -6         |

It is observed that only the last case satisfies the given condition that a and b are integers with opposite signs.

So, a = 15 and b = (-6)

So, the required ratio =  $a^2:b^2 = 225:36 = 25:4$

Hence, option (D) is the correct answer.

14. A class consists of 20 boys and 30 girls. In the mid-semester examination, the average score of the girls was 5 higher than that of the boys. In the final exam, however, the average score of the girls dropped by 3 while the average score of the entire class increased by 2. The increase in the average score of the boys is:

- A. 9.5.
- B. 10.
- C. 4.5.
- D. 6.

**Answer:** A

**Solution:**

Let 'X' denote the average marks scored by boys in mid-semester.

| Gender | Mid-semester |     |         |
|--------|--------------|-----|---------|
|        | Number       | Avg | total   |
| Girl   | 30           | x+5 | 30x+150 |
| Boy    | 20           | X   | 20x     |
| Total  | 50           | x+3 | 50x+150 |

In the final exam,

Sum of the girls =  $30(x + 2) = 30x + 60$

The overall sum of the entire class =  $50(x+5) = 50x+250$

Sum of the boys = Overall sum – Sum of the girls

Sum of the boys =  $50x + 250 - (30x + 60) = 20x + 190$

So, average for the boys in the final examination will be  $\text{sum}/20 = \frac{20x+190}{20} = x + 9.5$

So, their average has increased by 9.5.

Hence, option (A) is the correct answer.

15. The area of the closed region bounded by the equation  $|x| + |y| = 2$  in the two-dimensional plane is

- A.  $4\pi$ .
- B. 4.
- C. 8.
- D.  $2\pi$ .

**Answer:** C

**Solution:**

Given,  $|x| + |y| = 2$

Considering  $x = 0$ , we get  $y = 2$  or  $-2$

Also,  $y = 0$ , we get  $x = 2$  or  $-2$

So, the graph will cut the axes at 2 unit distances from the origin.

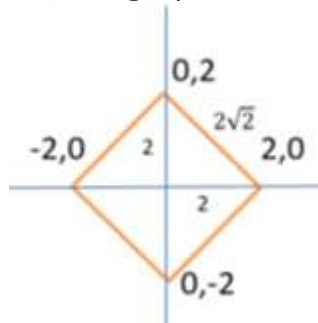

We can see that the bound region is a square with sides  $2\sqrt{2}$  units

So, the area is 8 square units.

Hence, option (C) is the correct answer.

16. From a triangle ABC with sides of lengths 40 ft, 25 ft and 35 ft, a triangular portion GBC is cut off where G is the centroid of ABC. The area, in sq. ft, of the remaining portion of triangle ABC is:

- A.  $225\sqrt{3}$ .
- B.  $500/\sqrt{3}$ .
- C.  $275/\sqrt{3}$ .
- D.  $250/\sqrt{3}$ .

**Answer:** B

**Solution:**

For any triangle, if the sides are  $a$ ,  $b$  and  $c$ , then the area is  $\sqrt{s(s-a)(s-b)(s-c)}$ , where 's' is the semi perimeter. Here, the semi perimeter is 50 cm.

So, the area is  $\sqrt{50 \times (50 - 40) \times (50 - 25) \times (50 - 35)} = 250\sqrt{3}$ .

On joining the vertices of any triangle to the centroid of that triangle, three triangles are formed with equal area.

So, triangle GBC will be one-third of the area of triangle ABC.

So, the area of the triangle GBC is  $\frac{250\sqrt{3}}{3} = \frac{250}{\sqrt{3}}$ .

Hence, option (D) is the correct answer.

17. Let ABC be a right-angled isosceles triangle with hypotenuse BC. Let BQC be a semi-circle, away from A, with diameter BC. Let BPC be an arc of a circle centered at A and lying between BC and BQC. If AB has a length of 6 cm then the area, in sq. cm, of the region enclosed by BPC and BQC is:

- A.  $9\pi - 18$
- B. 18
- C.  $9\pi$
- D. 9

**Answer:** B

**Solution:**

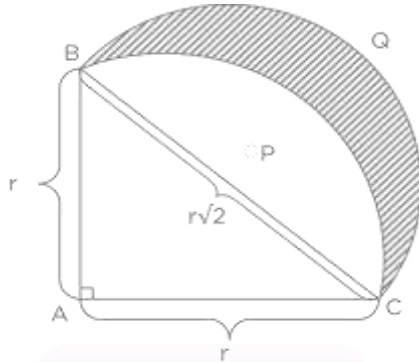

As the side of the triangle is  $r = 6\text{ cm}$ , length of hypotenuse is  $6\sqrt{2}$  cm.

So, for the semi circle, the radius  $= \frac{6}{\sqrt{2}}$  cm.

So, the area of the semi circle  $= \frac{\pi 6^2}{2} \times \frac{1}{2} = 9\pi \text{ cm}^2$

Area of the sector BPCB = Area of the quadrant – Area of the triangle

Area of sector  $= \frac{1}{4}\pi 6^2 - \frac{6^2}{2}$

Area of the shaded region is  $= 9\pi - \left(\frac{1}{4}\pi 6^2 - \frac{6^2}{2}\right) = \frac{6^2}{2} = 18$

Hence, option (B) is the correct answer.

18. A solid metallic cube is melted to form five solid cubes whose volumes are in the ratio 1:1:8:27:27. The percentage by which the sum of the surface areas of these five cubes exceeds the surface area of the original cube is the nearest to:

- A. 10.
- B. 50.
- C. 60.
- D. 20.

**Answer:** B

**Solution:**

Ratio of the volumes of the 5 new cubes = 1:1:8:27:27

So, the ratio of the sides of the 5 new cubes = 1:1:2:3:3 = k: k:2k:3k:3k,

where k is a non-zero constant.

Ratio of the volumes of the 5 new cubes =  $k^3:k^3:8k^3:27k^3:27k^3$

Total volume =  $64k^3$  = Volume of the initial large cube

Side of the initial large cube = 4k

Total surface area of the initial large cube =  $6 \times (4k)^2 = 96k^2$

Total surface area of all the 5 new smaller cubes =  $6\{k^2 + k^2 + 4k^2 + 9k^2 + 9k^2\} = 6 \times 24k^2 = 144k^2$

Percentage increase =  $\frac{144k^2 - 96k^2}{96k^2} \times 100\% = 50\%$

Hence, option (B) is the correct answer.

19. A ball of diameter 4 cm is kept on top of a hollow cylinder standing vertically. The height of the cylinder is 3 cm, while its volume is  $9\pi \text{ cm}^3$ . Then the vertical distance, in cm, of the topmost point of the ball from the base of the cylinder is:

**Answer:** 6

**Solution:**

Let the radius of the cylinder be  $r$ .

Volume =  $\pi r^2 h = 9\pi$

As  $h = 3$ , then  $r = \sqrt{3}$ .

So, the diameter of the cylinder will be  $2\sqrt{3}$ .

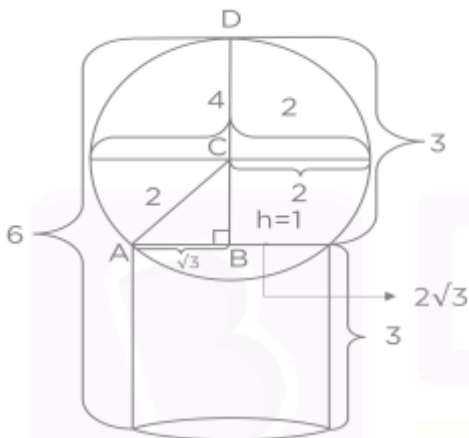

From this diagram, we can see that CB is perpendicular to AB.

Using Pythagoras Theorem, we will get,  $CB = 1\text{m}$

So, the required height = height of the cylinder +  $BD = 3 + 3 = 6\text{m}$

Hence, 6 is the correct answer.

20. Let ABC be a right-angled triangle with BC as the hypotenuse. Lengths of AB and AC are 15 km and 20 km, respectively. The minimum possible time, in minutes, required to reach the hypotenuse from A at a speed of 30 km per hour is:

**Answer:** 24

**Solution:**

Since the two sides are 15 and 20 km then using Pythagoras theorem, the hypotenuse is 25 km.

Area of the triangle =  $\frac{1}{2} \times \text{Base} \times \text{Height} = \frac{1}{2} \times 15 \times 20 = 150$  square km

So, the length of the perpendicular drawn on the hypotenuse from the right angular vertex is H (let).

So,  $\frac{1}{2} \times 25 \times H = 150$  or  $H = 12$

So, at a speed of 30 kmph, the time taken will be  $12/30$  hours = 24 minutes

Hence, 24 is the correct answer.



21. Suppose,  $\log_3 x = \log_{12} y = a$ , where  $x, y$  are positive numbers. If  $G$  is the geometric mean of  $x$  and  $y$ , and  $\log_6 G$  is equal to:

- A.  $\sqrt{a}$ .
- B.  $2a$ .
- C.  $\frac{a}{2}$ .
- D.  $a$ .

**Answer:** D

**Solution:**

Given,  $\log_3 x = \log_{12} y = a$

$x = 3^a$  and  $y = 12^a$

$$G = \sqrt{xy} = \sqrt{3^a \times 12^a} = \sqrt{36^a} = 6^a$$

$\log_6 G = a$

Hence, option (D) is the correct answer.

22. If  $x + 1 = x^2$  and  $x > 0$ , then  $2x^4$  is:

- A.  $6 + 4\sqrt{5}$ .
- B.  $3 + 5\sqrt{5}$ .
- C.  $5 + 3\sqrt{5}$ .
- D.  $7 + 3\sqrt{5}$ .

**Answer:** D

**Solution:**

Since  $x + 1 = x^2$  and  $x > 0$

Solving for using formula, we have  $x = \frac{1 \pm \sqrt{5}}{2}$  or  $2x = 1 \pm \sqrt{5}$

On squaring both sides,  $4x^2 = 6 \pm 2\sqrt{5}$

Dividing both sides by 2,  $2x^2 = 3 \pm \sqrt{5}$

Squaring both sides again,  $4x^4 = 14 \pm 6\sqrt{5}$

Dividing both sides by 2 again,  $2x^4 = 7 \pm 3\sqrt{5}$

Hence, option (D) is the correct answer.

23. The value of  $\log_{0.008} \sqrt{5} + \log_{\sqrt{3}} 81 - 7$  is equal to:

- A.  $1/3$ .
- B.  $2/3$ .
- C.  $5/6$ .
- D.  $7/6$ .

**Answer:** C

**Solution:**

$$\log_{0.008} \sqrt{5} + \log_{\sqrt{3}} 81 - 7 =$$

$$\log_{0.008} 5^{\frac{1}{2}} + \log_{\sqrt{3}} 3^4 - 7 = \frac{1}{-3} \log_5 5 + \frac{4}{\frac{1}{2}} \log_3 3 - 7 = -\frac{1}{6} + 8 - 7 = \frac{5}{6}$$

Hence, option (C) is the correct answer.

24. If  $9^{2x-1} - 81^{x-1} = 1944$ , then  $x$  is

- A. 3.
- B.  $\frac{9}{4}$ .
- C.  $4/9$ .
- D.  $1/3$ .

**Answer:** B

**Solution:**

$$9^{2x-1} - 81^{x-1} = 1944$$

$$\frac{81^x}{9} - \frac{81^x}{81} = 1944$$

$$8 \times 81^x = 1944 \times 81$$

$$81^x = 243 \times 81 = 3^5 \times 3^4 = 3^9$$

$$3^{4x} = 3^9$$

$$4x = 9$$

$$x = 9/4$$

Hence, option (B) is the correct answer.

25. The number of solutions (x, y, z) to the equation  $x - y - z = 25$ , where x, y, and z are positive integers such that  $x \leq 40$ ,  $y \leq 12$ , and  $z \leq 12$  is

- A. 101.
- B. 99.
- C. 87.
- D. 105.

**Answer:** B

**Solution:**

All the possible values of x, y and z will be,

|    | X  | Y    |    | Z    |    | TOTAL |
|----|----|------|----|------|----|-------|
|    |    | FROM | TO | FROM | TO |       |
| 1  | 40 | 3    | 12 | 12   | 3  | 10    |
| 2  | 39 | 2    | 12 | 12   | 2  | 11    |
| 3  | 38 | 1    | 12 | 12   | 1  | 12    |
| 4  | 37 | 1    | 11 | 11   | 1  | 11    |
| 5  | 36 | 1    | 10 | 10   | 1  | 10    |
| 6  | 35 | 1    | 9  | 9    | 1  | 9     |
| 7  | 34 | 1    | 8  | 8    | 1  | 8     |
| 8  | 33 | 1    | 7  | 7    | 1  | 7     |
| 9  | 32 | 1    | 6  | 6    | 1  | 6     |
| 10 | 31 | 1    | 5  | 5    | 1  | 5     |
| 11 | 30 | 1    | 4  | 4    | 1  | 4     |
| 12 | 29 | 1    | 3  | 3    | 1  | 3     |
| 13 | 28 | 1    | 2  | 2    | 1  | 2     |
| 14 | 27 | 1    | 1  | 1    | 1  | 1     |
|    |    |      |    |      |    | 99    |

Hence, option (B) is the correct answer.

26. For how many integers  $n$ , will the inequality  $(n - 5)(n - 10) - 3(n - 2) \leq 0$  be satisfied?

**Answer:** 11

**Solution:**

Given,

$$(n - 5)(n - 10) - 3(n - 2) \leq 0$$

$$n^2 - 5n - 10n + 50 - 3n + 6 \leq 0$$

$$n^2 - 18n + 56 \leq 0$$

$$(n-4)(n-14) \leq 0$$

$$4 \leq n \leq 14$$

There are  $14 - 4 + 1 = 11$  integers.

Hence, 11 is the correct answer.

27.  $f_1(x) = x^2 + 11x + n$  and  $f_2(x) = x$ , then the largest positive integer  $n$  for which the equation  $f_1(x) = f_2(x)$  has two distinct real roots, is:

**Answer:** 24

**Solution:**

We get,  $x^2 + 11x + n = x$

$$x^2 + 10x + n = 0$$

Since it has two distinct real roots, the discriminant is greater than zero.

So,  $10^2 - 4n > 0$  or  $25 > n$

So, the largest positive integer value of  $n$  is 24.

Hence, 24 is the correct answer.

28. If  $a, b, c,$  and  $d$  are integers such that  $a + b + c + d = 30$ , then the minimum possible value of  $(a - b)^2 + (a - c)^2 + (a - d)^2$  is

**Answer:** 2.

**Solution:**

The value will be minimum when the values of  $a, b, c, d$  are closest.

So, the values can be  $(7, 7, 8, 8)$  in any order.

So, the minimum possible value is  $= (7 - 7)^2 + (7 - 8)^2 + (7 - 8)^2 = 2$

Hence, 2 is the correct answer.

29. Let  $AB, CD, EF, GH,$  and  $JK$  be five diameters of a circle with centre at  $O$ . In how many ways, can three points be chosen out of  $A, B, C, D, E, F, G, H, J, K,$  and  $O$  so as to form a triangle?

**Answer:** 160

**Solution:**

There are in total 11 points and any 3 can be selected in  ${}^{11}C_3 = 165$  ways.

Selecting  $AOB, COD, EOF, GOH$  and  $JOK$  does not give triangles.

So, the total acceptable number of ways  $= 165 - 5 = 160$

30. The shortest distance of the point  $(1/2, 1)$  from the curve  $y = |x - 1| + |x + 1|$  is

- A. 1.
- B. 0.
- C.  $\sqrt{2}$ .
- D.  $\sqrt{3/2}$ .

**Answer:** A

**Solution:**

The given point  $(1/2, 1)$  is in the first quadrant.

Now, the given equation  $y = |x - 1| + |x + 1|$

We can rewrite the given equation in the following cases:

| Case         | $ x - 1 $ | $ x + 1 $ | $y$   |
|--------------|-----------|-----------|-------|
| $X < -1$     | $1 - x$   | $-x - 1$  | $-2x$ |
| $X = -1$     | 2         | 0         | 2     |
| $-1 < x < 1$ | $1 - x$   | $X + 1$   | 2     |
| $X = 1$      | 0         | 2         | 2     |
| $1 < x$      | $x - 1$   | $X + 1$   | $2x$  |

So, the graph will be:

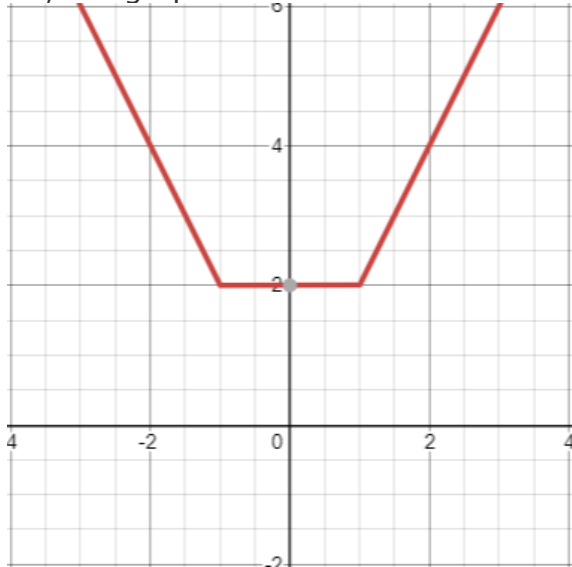

Now,  $(1/2, 1)$  is closest to the horizontal part of the above graph.

As the horizontal part represents  $y = 2$ , the distance from  $(1/2, 1)$  will be  $2 - 1 = 1$ . Hence, option (A) is the correct answer.

31. If the square of the 7<sup>th</sup> term of an arithmetic progression with positive common difference equals the product of the 3<sup>rd</sup> and 17<sup>th</sup> terms, then the ratio of the first term to the common difference is:

- A. 2:3.
- B. 3:2.
- C. 3:4.
- D. 4:3.

**Answer:** A

**Solution:**

Let the first term be  $a$  and the common difference be  $d$ .

So, 3<sup>rd</sup> term =  $a + 2d$ , 7<sup>th</sup> term =  $a + 6d$  and 17<sup>th</sup> term =  $a + 16d$

According to the question,  $(a + 6d)^2 = (a + 2d)(a + 16d)$

$$a^2 + 36d^2 + 12ad = a^2 + 2ad + 16ad + 32d^2$$

$$2d = 3a$$

$$2/3 = a/d$$

$$a:d = 2:3$$

Hence, option (A) is the correct answer.

32. In how many ways can 7 identical erasers be distributed among 4 kids in such a way that each kid gets at least one eraser, but nobody gets more than 3 erasers?

- A. 16
- B. 20
- C. 14
- D. 15

**Answer:** A

**Solution:**

The possible arrangements are:

$$1, 1, 2, 3 \text{ and number of arrangements} = \frac{4!}{2!} = 12$$

$$1, 2, 2, 2 \text{ and number of arrangements} = \frac{4!}{3!} = 4$$

Total = 16

Hence, option (A) is the correct answer.

33. If  $f(x) = (5x + 2)/(3x - 5)$  and  $g(x) = x^2 - 2x - 1$ , then the value of  $g(f(f(3)))$  is:

- A. 2.
- B. 1/3.
- C. 6.
- D. 2/3.

**Answer:** A

**Solution:**

$$g(f(f(3))) = g(f(17/4)) = g(3) = 3^2 - 2 \times 3 - 1 = 9 - 6 - 1 = 2.$$

Hence, option (A) is the correct answer.

34. Let  $a_1, a_2, \dots, a_{3n}$  be an arithmetic progression with  $a_1 = 3$  and  $a_2 = 7$ . If  $a_1 + a_2 + \dots + a_{3n} = 1830$ , then what is the smallest positive integer  $m$  such that  $m(a_1 + a_2 + \dots + a_n) > 1830$ ?

- A. 8
- B. 9
- C. 10
- D. 11

**Answer:** B

**Solution:**

The given AP has first term = 3 and second term = 7

So, the common difference = 4

$$\text{So, sum up to } 3n^{\text{th}} \text{ term} = \frac{3n}{2}(2 \times 3 + (3n - 1) \times 4) = 3n(3 + 6n - 2) = 3n(6n + 1)$$

$$\text{So, } 3n(6n + 1) = 1830$$

$$\text{Or } n(6n + 1) = 610$$

$$\text{Or } 6n^2 + n - 610 = 0 \text{ or } n = 10$$

$$\text{Now, sum up to } 10^{\text{th}} \text{ term} = \frac{10}{2}(2 \times 3 + 9 \times 4) = 5(6 + 36) = 210$$

$$\text{So, } 210m > 1830$$

$$\text{So, } m > 8.7$$

So, minimum value of  $m = 9$

Hence, option (B) is the correct answer.

# PREPARE FOR CAT

NMAT, IIFT, XAT, CMAT, Mah-CET, SNAP, TISSNET & More

Hello Aspirant,

Did you know that clearing **MBA Exams** with good scores makes you eligible for **Top Business Schools** in India? It helps you get reputed jobs as a **successful manager** and enjoy the benefits of a secure future.

At **BYJU'S Exam Prep** we understand the importance of your career goals. So, to ensure that you are moving in the right direction for your **perfect exam preparation**, we offer you an **Online Classroom Program** where you will get **comprehensive preparation** for all your exams.

So why wait? Join **BYJU'S Exam Prep today** and get closer to your dream job.

[Know More](#)



- Live Classes by Top Faculty
- Enhanced Preparation with Daily Study Plans for Consistent Learning
- Comprehensive Study Material designed by Subject Experts
- Unlimited Latest Pattern Test Series
- 100% Doubt Resolution by Experienced Faculty
- Report Card with In-depth Analysis of Current Performance Level

## Prepare With Our Expert Faculty

### SARAL NASHIER

Quant & DILR Expert  
99.9%ile In CAT  
Exp.: 16+ Years

### PRANAV PANT

Quant & DILR Expert  
99.9+%ile In CAT  
100%ile DI-LR CAT 2016

### SANOUJAM DASOBANTA

English Expert  
99.9+%ile VARC, CAT  
Exp.: 17+ Years

and many more...

## Our Achievers

**99.92%ile  
CAT**

Bharath Reddy

**99.90%ile  
CAT**

Shreyansh Sinha

**99.10%ile  
CAT**

Lalit Singhal