

IMPORTANT FORMULAS TO REMEMBER

Chapter-1

Error Analysis

Measurement is a process by which one can convert physical parameters to meaningful numbers. The measuring process is one in which the property of an object or system under consideration is compared to an accepted standard unit, a standard defined for that particular property.

Static Characteristics

1. Accuracy

It is the closeness with which an instrument reading approaches the true value of the quantity being measured.

2. Precision

It is a measure of the reproducibility of the measurements. It is a measure of degree of agreement within a group of measurements.

Remember:

- Precision is not the guarantee of accuracy.
- An instrument with more significant figure has more precision.

3. Sensitivity

It is the ratio of the magnitude of output signal to the magnitude of input signal applied to the instrument.

$$\text{Sensitivity} = \frac{\text{Output}}{\text{Input}}$$

Note:

- An instrument requires high degree of sensitivity

$$\text{Sensitivity} \propto \frac{1}{\text{Deflection factor}}$$

4. Resolution

The smallest change in input which can be detected with certainty by an instrument is its resolution.

5. Linearity

The output is linearly proportional to the input. For a linear instrument, the sensitivity is constant for the entire range of instrument.

Linearity is the most important parameter compared to all other parameters.

Remember:

- Linearity is more important than the sensitivity.
- Accuracy is more important than resolution.

6. Dead Zone

It is the largest change of input quantity for which there is no output of the instrument.

7. Dead time

Time required by an instrument to begin to respond to the change in a measurand.

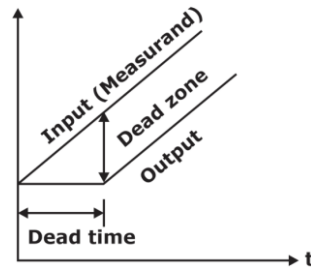

8. Range and Span

The difference between the maximum and the minimum values of the scale is called range. The maximum value of the scale is called span.

Errors

Error = Measured value - True value = Accuracy

- Static Error

$$\delta A = A_m - A_t$$

Where,

A_m = Measured value of quantity or Actual value

A_t = True value of quantity or Nominal value

Relative static error

$$\epsilon_r = \frac{\delta A}{A_t}$$

Static correction

$$\delta C = A_t - A_m = -\delta A$$

Static Sensitivity

$$\text{Static sensitivity} = \frac{\Delta q_o}{\Delta q_i}$$

Where, Δq_o = Infinitesimal change in output, Δq_i = Infinitesimal change in input

Non-linearity (N.L.)

$$\text{N.L.} = \frac{(\text{Max. deviation of output from the idealized straight line})}{\text{Full scale deflection}} \times 100$$

$$\text{Error at desired value} = \frac{\text{Full scale value} \times \text{Error at full scale}}{\text{Desired value}}$$

Combination of Quantities with Limiting Errors Sum or Difference of Two or More than Two Quantities

$$\text{Let } X = \pm X_1 \pm X_2 \pm X_3 \pm X_4$$

Where,

$\pm \delta X_1$ = Relative increment in quantity X_1

$\pm \delta X_2$ = Relative increment in quantity X_2

$\pm \delta X$ = Relative increment in X

$$\frac{\delta X_1}{X_1} = \text{Relative limiting error in quantity } X_1$$

$$\frac{\delta X_2}{X_2} = \text{Relative limiting error in quantity } X_2$$

$$\frac{\delta X}{X} = \text{Relative limiting error in } X$$

Product or Quotient of Two or More than two Quantities

$$\text{Let } X = X_1 X_2 X_3 \text{ or } X = \frac{X_1}{X_2 X_3} \text{ or } X = \frac{1}{X_1 X_2 X_3}$$

$$\frac{\delta X}{X} = \pm \left(\frac{\delta X_1}{X_1} + \frac{\delta X_2}{X_2} + \frac{\delta X_3}{X_3} \right)$$

Composite Factors

$$\text{Let } X = X_1^n \cdot X_2^m$$

$$\frac{\delta X}{X} = \pm \left(n \frac{\delta X_1}{X_1} + m \frac{\delta X_2}{X_2} \right)$$

Arithmetic Mean

$$\bar{X} = \frac{\sum X}{n} = \frac{X_1 + X_2 + \dots + X_n}{n}$$

where, $X_1, X_2, \dots, X_n =$ Readings or samples, $n =$ Number of readings

Deviation

$$d_n = x_n - \bar{X}$$

Note: Algebraic sum of deviation is zero.

$$\text{Average deviation, } \bar{D} = \frac{\sum |d|}{n} = \frac{|d_1| + |d_2| + \dots + |d_n|}{n}$$

Standard deviation

$$\text{for } n > 20, \text{ S.D.} = \sigma = \sqrt{\frac{\sum d^2}{n}} = \sqrt{\frac{d_1^2 + d_2^2 + \dots + d_n^2}{n}}$$

$$\text{For } n < 20, \text{ S.D.} = s = \sqrt{\frac{\sum d^2}{n-1}}$$

Variance

$$\text{for } n > 20, \text{ V} = \sigma^2 = \frac{\sum d^2}{n}$$

$$\text{For } n < 20, \text{ V} = s^2 = \frac{\sum d^2}{n-1}$$

Normal or Gaussian Curve of Errors

1. For Infinite Numbers of reading

$$y = \frac{1}{\sigma\sqrt{2\pi}} \exp\left(-x^2 / 2\sigma^2\right)$$

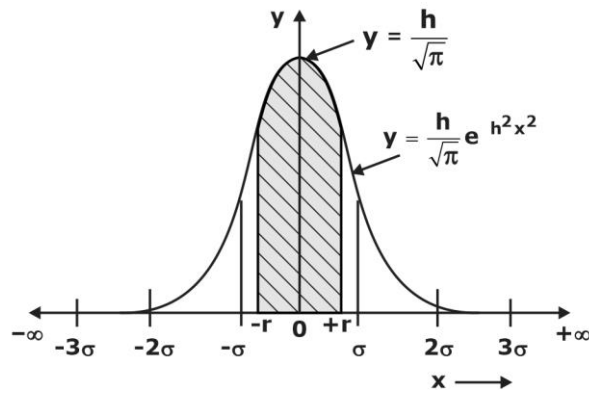

Where, x = magnitude of deviation from mean, y = number of reading at any deviation x ,

(the probability of occurrence of deviation x)

σ = standard deviation

Precision Index

$$h = \frac{1}{\sigma\sqrt{2}}$$

Probable error (P.E.)

$$r = \frac{0.4769}{h}$$

Average deviation

$$D = \frac{r}{0.8453} = \frac{1}{\pi h^2}$$

Standard deviation

$$\sigma = \frac{r}{0.8745} = \frac{1}{h\sqrt{2}}$$

$$P.E. = r = 0.8453 \bar{D} = 0.6745\sigma$$

2. For Finite Numbers of Reading

$$\text{For } n > 20, P.E. = r = 0.6745 \sqrt{\frac{\sum |d|^2}{n}}$$

$$\text{For } n < 20, P.E. = r = 0.6745 \sqrt{\frac{\sum |d|^2}{n-1}}$$

$$\text{Standard deviation of mean, } \sigma_m = \frac{\sigma}{\sqrt{n}}$$

$$\text{Standard deviation of standard deviation, } \sigma_\sigma = \frac{\sigma_m}{\sqrt{2}}$$

Variance of combination of components

Let $x = f(X_1, X_2, \dots, X_n)$

$$V_x = \left(\frac{\partial X}{\partial x_1}\right)^2 V_{x_1} + \left(\frac{\partial X}{\partial x_2}\right)^2 V_{x_2} + \dots + \left(\frac{\partial X}{\partial x_n}\right)^2 V_{x_n} \text{ where,}$$

$V_{x_1}, V_{x_2}, \dots, V_{x_n}$ = variance of x_1, x_2, \dots, x_n

Standard Deviation of Combination of Components

Let $x = f(x_1, x_2, \dots, x_n)$

$$\sigma_x = \left(\frac{\partial X}{\partial x_1}\right)^2 \sigma_{x_1}^2 + \left(\frac{\partial X}{\partial x_2}\right)^2 \sigma_{x_2}^2 + \dots + \left(\frac{\partial X}{\partial x_n}\right)^2 \sigma_{x_n}^2$$

where, $\sigma_{x_1}, \sigma_{x_2}, \dots, \sigma_{x_n}$ = Standard deviation of x_1, x_2, \dots, x_n

Probable Error of Combination of Components

Let $X = f(x_1, x_2, \dots, x_n)$

$$r_x = \sqrt{\left(\frac{\partial X}{\partial x_1}\right)^2 r_{x_1}^2 + \left(\frac{\partial X}{\partial x_2}\right)^2 r_{x_2}^2 + \dots + \left(\frac{\partial X}{\partial x_n}\right)^2 r_{x_n}^2}$$

Where $r_{x_1}, r_{x_2}, \dots, r_{x_n}$ = Probable error of

x_1, x_2, \dots, x_n

Uncertainty of Combination of Components

Let $X = f(x_1, x_2, \dots, x_n)$

$$W_x = \sqrt{\left(\frac{\partial X}{\partial x_1}\right)^2 W_{x_1}^2 + \left(\frac{\partial X}{\partial x_2}\right)^2 W_{x_2}^2 + \dots + \left(\frac{\partial X}{\partial x_n}\right)^2 W_{x_n}^2}$$

Where $W_{x_1}, W_{x_2}, \dots, W_{x_n}$ = Uncertainties of x_1, x_2, \dots, x_n

Chapter-2

Measurement of Current & Voltage

D'Arsonval Galvanometer

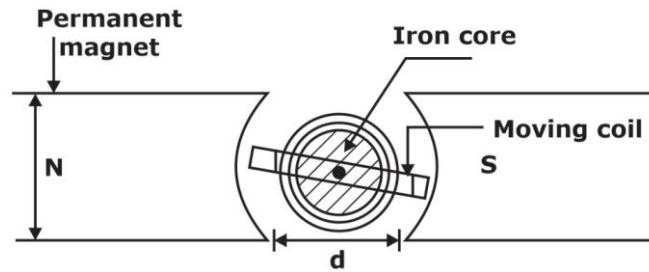

Deflecting torque

$$T_d = BINA = GI$$

Where ,

B = Flux density in air gap; Wb/m^2

I = current through moving coil ; A

N = Number of turns in coil

$A = l \cdot d$ = Area of coil; m^2

l, d = Length of vertical and horizontal side (width) of coil respectively; m

G = Displacement constant of galvanometer

Controlling torque

$$T_c = K\theta_f$$

Where,

K = Spring constant of suspension; Nm/rad

θ_f = Final steady deflection of moving coil;

Final steady deflection

$$\theta_f = \left(\frac{NBA}{K} \right) i = \left(\frac{G}{K} \right) i$$

Dynamic behavior of Torques in Galvanometers

$$\text{Inertia torque, } T_j = J \frac{d^2\theta}{dt^2}$$

Where, J = moment of inertia of moving system about the axis of rotation; kg-m^2 ,

θ = deflection at any time t ; radian

$$\text{Damping torque, } T_D = D \frac{d\theta}{dt}$$

Where, D = damping constant

Controlling torque, $T_c = K\theta$ Where, K = control constant

Deflecting Torque, $T_d = GI$

Equation of motion, $T_j + T_D + T_C = T_d$

$$J \frac{d^2\theta}{dt^2} + \frac{Dd\theta}{dt} + K\theta = GI$$

Note:

If $D^2 < 4 KJ$, galvanometer is under-damped.

If $D^2 = 4 KJ$, galvanometer is critically damped.

If $D^2 > 4 KJ$, galvanometer is over-damped.

Total resistance of galvanometer circuit for critical damping, $R = \frac{G^2}{2\sqrt{KJ}}$

External series resistance required for critical damping, $R_e = R - R_g = \frac{G^2}{2\sqrt{KJ}} - R_g$

Where, R_g = Resistance of galvanometer

Sensitivity

Current sensitivity

$$S_i = \frac{\theta_f}{i} = \frac{G}{k} \text{ rad/A} = \frac{d}{1 \times 10^6} \text{ scale divisions} / \mu\text{A} = \frac{2000G}{K \times 10^6} \text{ mm} / \mu\text{A}$$

Voltage sensitivity

$$S_v = \frac{d}{iR_g \times 10^6} \text{ scale division} / \mu\text{V}$$

Mega ohm sensitivity

$$S_o = \frac{d}{i \times 10^{-6}} \text{ M}\Omega / \text{scale division}$$

Remember:

Sensitive galvanometer is one which produces a large deflection for a small current.

Classification of Analog Meters

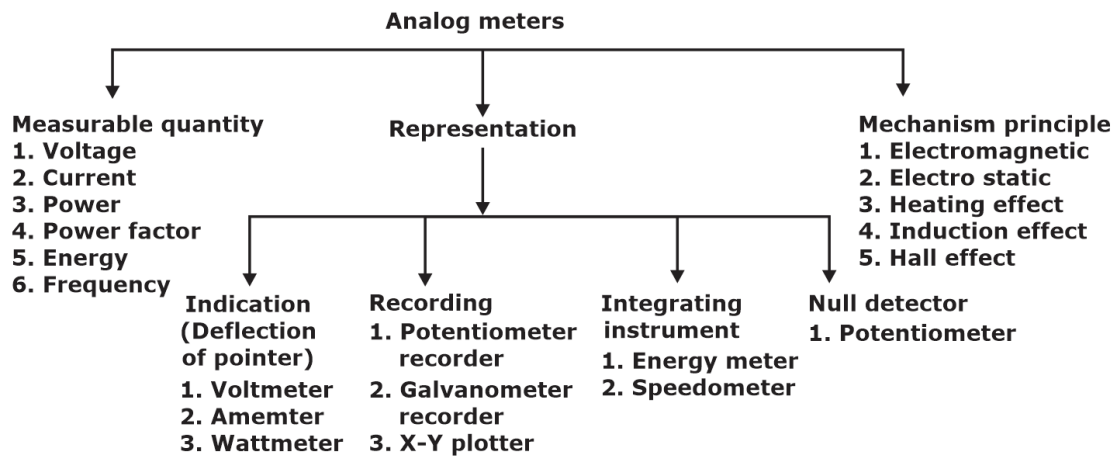

Torque in Analog Meter

1. Deflecting Torque (TD) is proportional to quantity under measurement. This torque deflects the pointer away from initial or zero position.

$$T_D \propto \text{measurable quantity}$$

2. Controlling Torque (TC)

The controlling torque is opposite to deflecting torque. When, deflecting torque equals to controlling torque, pointer comes to final steady state position.

At equilibrium, TC= TD

Note :

Control torque is also used to bring the pointer in zero initial position, if there is no deflecting torque.

Except in PMMC, in all other instruments if the control spring is failed or broken then pointer moves to the maximum position of scale.

Control torque is provided by

- (i) Spring control
- (ii) Gravity control

3. Damping Torque

It is used to damp out oscillation at final steady state position. The time response of the instrument depends on damping torque.

Damping torque provided by:

- (i) Air friction damping; Used where low magnetic fields are produced.
- (ii) Fluid friction damping; Used where deflecting torque is minimum.
- (iii) Eddy current damping; Used where permanent magnet produces the required deflecting torque.

Error in Analog Meters

1. Frictional error

To reduce the frictional error, the torque to weight ratio of the instrument should be high.

2. Temperature error

Due to change in temperature, change in resistance of meters and shunts and series multiplier occurs. To reduce this effect, resistances are made up of manganin material.

3. Frequency error

Due to change in frequency, error is produced in instrument because change in frequency cause change in reactance. To reduce this error, a capacitance is used in case of voltmeter and for ammeter, the time constant and shunt impedance are maintained at same value.

Permanent Magnet Moving Coil (PMMC)

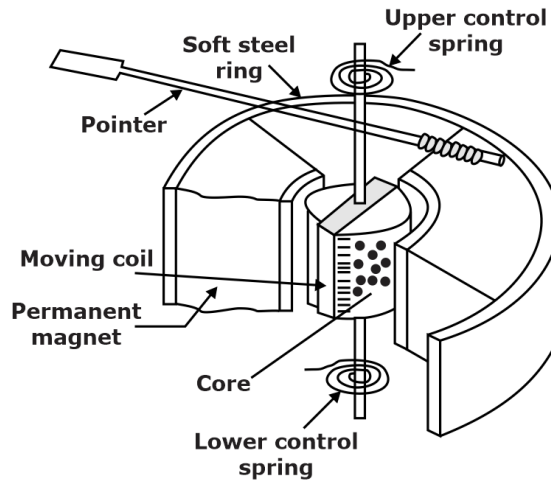

Deflection torque

$$T_D = nBAI, T_D = GI,$$

Where, $G = nBA$, $n =$ Number of turns, $B =$ Flux density, $A =$ Area of core

$I =$ Current to be measured

$$\text{Final steady state deflection, } \theta = \left(\frac{G}{k} \right) I$$

Where, $K =$ Spring constant

Note:

- PMMC instrument measures only DC or average values.
- Scale is linear.
- Spring is used for controlling torque.
- Damping torque provided by eddy current damping.
- It has high torque to weight ratio, so accuracy and sensitivity is higher compared to other instruments.
- In direct measurement, the PMMC measures up to a current of 50 mA or a voltage of 100 mV, without any external device.

Enhancement of Ammeters and Voltmeters

1. Ammeter Shunts

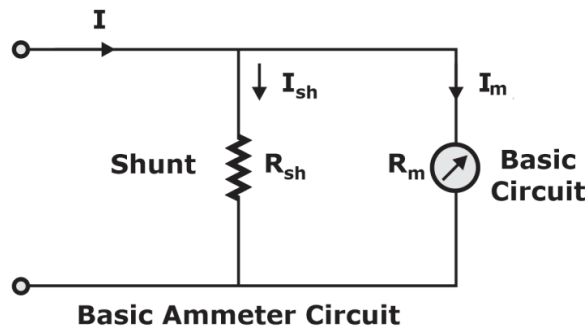

$$I_{sh}R_{sh} = I_mR_m$$

$$I = \left(1 + \frac{R_m}{R_{sh}} \right) I_m$$

where, $I =$ Current to be measured; $I_m = I_{fs} =$ Full scale deflection current; A

$R_m =$ Internal resistance of meter; Ω , $R_{sh} =$ Resistance of the shunt; Ω

Shunt resistance

$$R_{sh} = \frac{R_m}{m - 1}$$

Where, $m = \frac{I}{I_m} = 1 + \frac{R_m}{R_{sh}}$, m = Multiplying factor for shunt

Note:

To reduce the temperature effect, swamp resistance made up of manganin is added in series with ammeter.

2. Universal or Ayrton Shunt

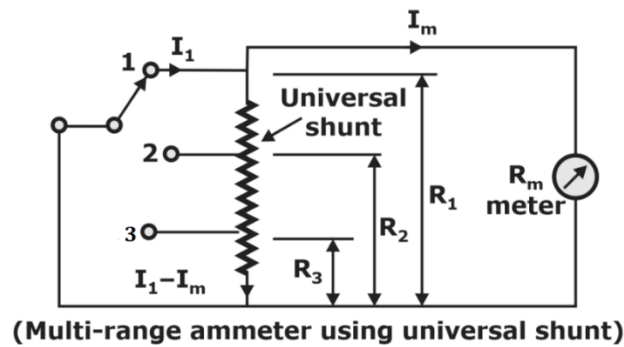

For switch at a position 1, $R_1 = \frac{R_m}{(m - 1)}$

For switch at a position 2, $R_2 = \frac{(R_1 + R_m)}{m_2}$

For switch at a position 3, $R_3 = \frac{(R_1 + R_m)}{m_3}$

Where, $m_1 = \frac{I_1}{I_m}$, $m_2 = \frac{I_2}{I_m}$, $m_3 = \frac{I_3}{I_m}$

3. Voltmeter Multipliers

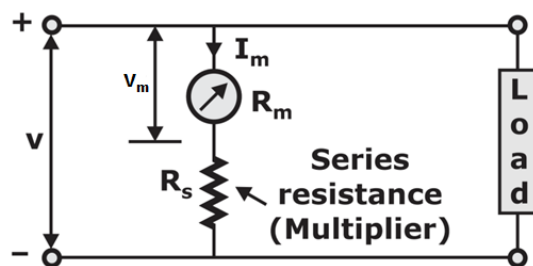

Multiplying factor for multiplier, $m = \frac{V}{V_m} = 1 + \frac{R_s}{R_m}$

Resistance of multiplier, $R_s = (m - 1)R_m$

Where, R_s = Multiplier resistance, R_m = Internal resistance of meter

4. Potential Divider Arrangement

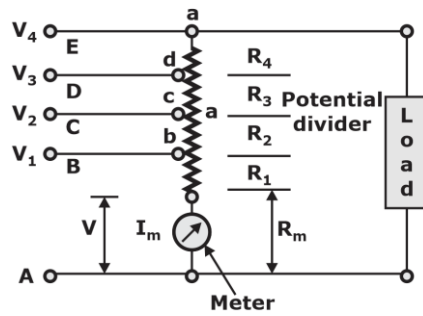

$$R_1 = (m - 1)R_m, \quad R_2 = (m_2 - m_1)R_m, \quad R_3 = (m_3 - m_2)R_m, \quad R_4 = (m_4 - m_3)R_m$$

Where, R_1 = Resistance between point a and b, R_2 = Resistance between point b and c

R_3 = Resistance between point a and d R_4 = Resistance between point d and e

$$\text{Voltmeter Sensitivity (VS), } S_v = \frac{1}{I_{fs}} = \frac{R_s + R_m}{V} \Omega/V$$

Remember:

To reduce loading effect, a voltmeter with higher value of sensitivity is preferred.

Moving Iron Instruments

$$\text{Deflecting torque, } T_d = \frac{1}{2} I^2 \frac{dL}{d\theta}, \quad \text{Deflection, } \theta = \frac{1}{2} \frac{I^2}{K} \frac{dL}{d\theta}$$

Note:

- Moving iron instrument measure both A.C and D.C. quantities.
- In case of A.C, it measures RMS Value.
- Scale is nonlinear.
- Controlling torque is provided by spring and air friction damping is used.
- Curve between $\frac{dL}{d\theta}$ and θ is rectangular hyperbola.

Shunts for Moving Iron Instruments

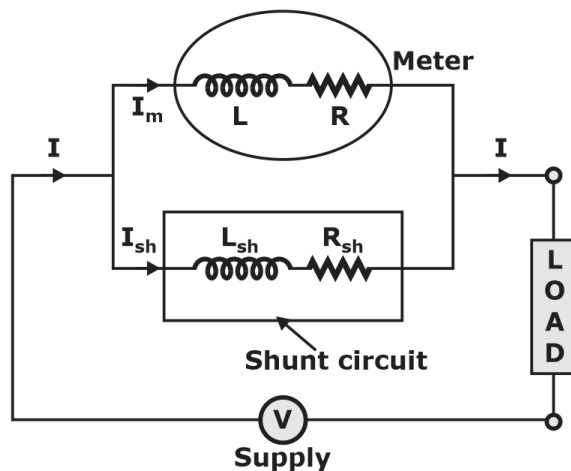

$$\frac{I_{sh}}{I_m} = \frac{R}{R_{sh}} \frac{\sqrt{1 + (\omega L / R)^2}}{\sqrt{1 + (\omega L_{sh} / R_{sh})^2}}$$

Multipliers for Moving Iron Instruments

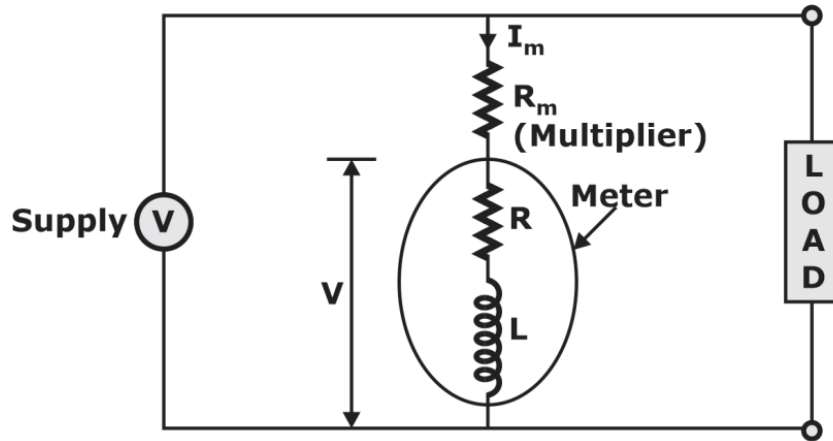

Voltage multiplying factor, $m = \frac{V}{v} = \frac{\sqrt{(R + R_m)^2 + \omega^2 L^2}}{\sqrt{R^2 + \omega^2 L^2}}$

Error in Moving Iron Instruments

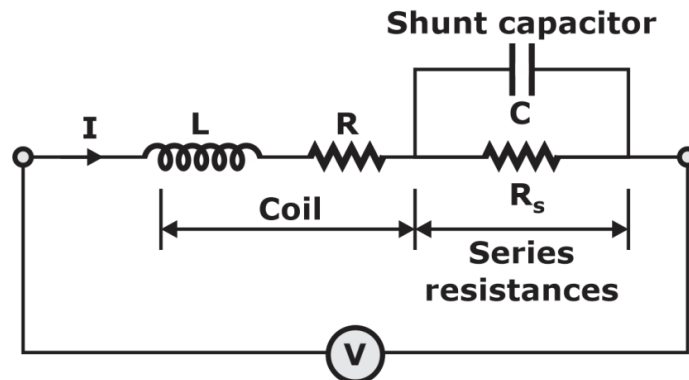

Shunt capacitance

$$C = 0.41 \frac{L}{R_s^2}$$

Eddy currents

When ω is small,

$$I'_e = \frac{\omega^2 M L_e I}{R_e^2}$$

When ω is large,

$$I'_e = \frac{M L_e I}{R_e} = \text{constant}$$

Where,

R_e, L_e = resistance and inductance of eddy current path

Note:

- Moving iron instrument is not suitable for measurement of current or voltage for frequency above 125 Hz because eddy current is constant at higher frequency.
- If meter time constant is equal to shunt time constant then ammeter is made independent of input supply frequency.
- To reduce hysteresis error, the iron part of moving iron is made up of Nickel iron alloy.
- To reduce the external stray magnetic fields.

Average current through diode vacuum tube voltmeters

$$I_{av} = \frac{E_{av}}{2R} = \frac{E_{rms}}{2 \times 1.11 \times R} = 0.45 \frac{E_{rms}}{R}$$

Where, E_{rms} = RMS value of applied voltage, E_{av} = Average value of applied voltage

R = Load resistance

Difference amplifier type of electronic voltmeter

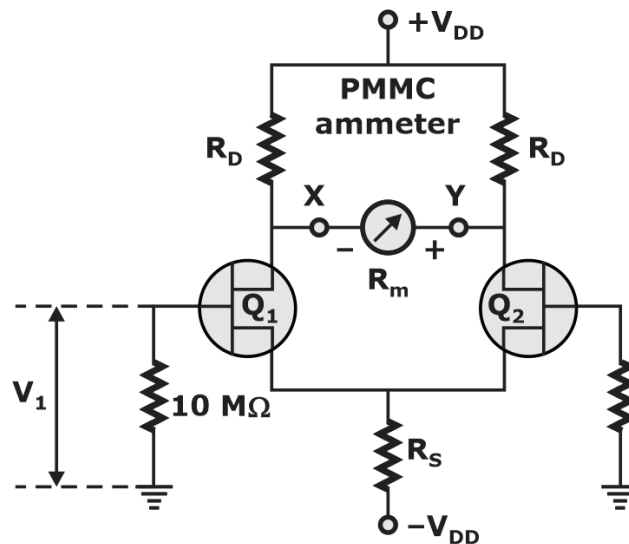

Thevenin's voltage across terminal X-Y

$$V_{Th} = g_m \left(\frac{r_d R_D}{r_d + R_D} \right) v_1$$

Thevenin's resistance looking into terminals X-Y

$$R_{Th} = \frac{2r_d R_D}{r_d + R_D}$$

Where, R_d = A.C. drain resistance in Ω , g_m = Transconductance in mho

$$\text{Current through ammeter, } i = \frac{V_{Th}}{R_{Th} + R_m} = \frac{g_m r_d R_D / (r_d + R_D)}{2r_d R_D / (r_d + R_D) + R_m} \cdot v_1$$

$$\text{Where, } R_D \ll r_d, \quad i = \frac{g_m R_D}{2R_D + R_m} \cdot v_1$$

Chapter-3

Measurement of Power & Energy

Electrodynamometer

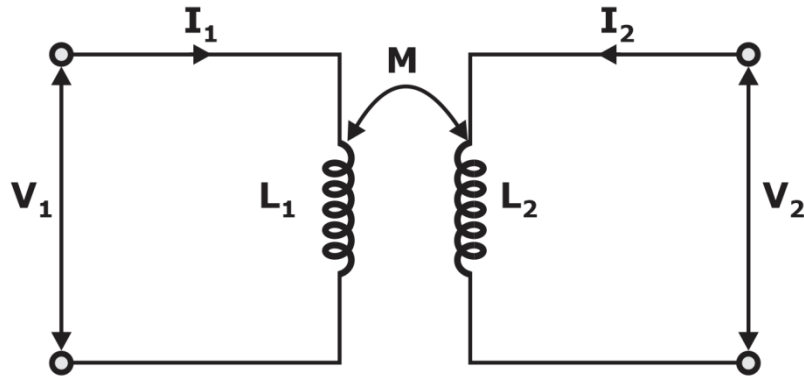

(a) If i_1 and i_2 are D.C current i.e. $i_1 = i_2 = I$, $T_d = I^2 \frac{dM}{d\theta}$ (Measure average value)

(b) If i_1 and i_2 are A.C current and no phase shift, $i_1 = i_2 = I$, $T_d = I^2 \frac{dM}{d\theta}$ (Measure RMS value)

(c) If $i_1 = I_{m1} \sin \omega t$ and $i_2 = I_{m2} \sin (\omega t - \phi)$, $T_d = I_1 I_2 \cos \phi \frac{dM}{d\theta}$ (Measure RMS value)

where, $I_1 = \frac{I_{m1}}{\sqrt{2}}$ and $I_2 = \frac{I_{m2}}{\sqrt{2}}$

Note:

- Electrodynamic instrument is a transfer instrument
- It measures both A.C. and D.C
- Scale is nonlinear.
- Its sensitivity is lesser than PMMC and M.I. type instrument.

Ratiometer

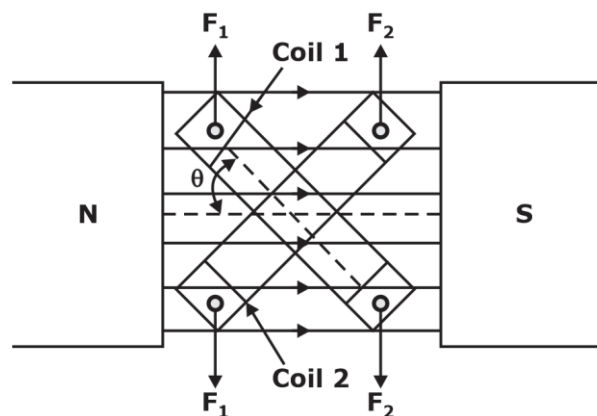

Deflecting torque acting on coil 1, $T_{d1} = N_1 B l_1 d_1 I_1 \cos \theta$

Deflecting torque acting on coil 2, $T_{d2} = N_2 B l_2 d_2 I_2 \cos \theta$

Where

I_1, I_2 = current in coil 1 and 2,

N_1, N_2 = Number of turns in coil 1 and 2

l_1, l_2 = length of coil 1 and 2,

d_1, d_2 = width of coil 1 and 2

B = flux density of magnetic field

Deflection at equilibrium, $\theta = k \left(\frac{I_1}{I_2} \right)$

Measurement of Power

1. D.C Circuits

Ammeter connected between load and voltmeter

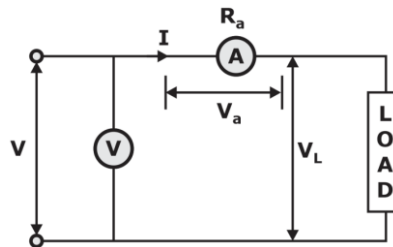

Power consumed by load :

$$P = VI - I^2 R_a$$

Where, V = Voltage across voltmeter, I = Current through ammeter, R_a = Resistance of ammeter

Voltmeter connected between load and ammeter

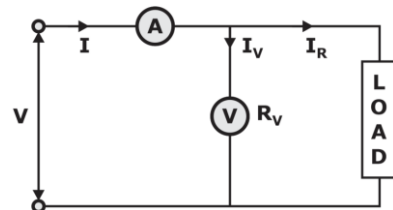

Power consumed by load :

$$P = VI - \frac{V^2}{R_v}$$

Where, V = Voltage across voltmeter, I = Current through ammeter,

R_v = Resistance of voltmeter

2. A.C. Circuits

Instantaneous power

$$p = vi = V_m I_m \sin \omega t \cdot \sin(\omega t - \phi)$$

Where $v = V_m \sin \omega t$, $i = I_m \sin(\omega t - \phi)$

$$\text{Average power, } P = VI \cos \phi = \frac{V_m I_m}{2} \cos \phi$$

Where, V, I = RMS values of voltage and current, $\cos \phi$ = Power factor of the load

Let

$$v = V_o + \sum_{n=1}^m V_n \sin(n\omega t + \theta_n) \text{ and } i = I_o \sum_{n=1}^m I_n \sin(n\omega t + \phi_n) \text{ then}$$

$$P_{avg} = V_o I_o + \frac{1}{2} \sum_{n=1}^m V_n I_n \cos[\theta_n - \phi_n]$$

Remember:

Wattmeter reads average active power.

Electrodynamometer Wattmeter

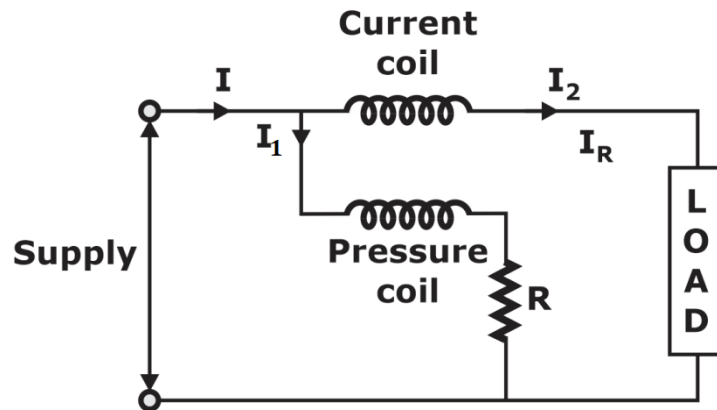

Instantaneous torque

$$T_i = i_1 i_2 \left(\frac{dM}{d\theta} \right)$$

where, i_1, i_2 = instantaneous value of current in pressure and current coils

Deflecting torque

$$T_d = \frac{VI}{R_p} \cos \phi \cdot \frac{dM}{d\theta}$$

Where, R_p = resistance of pressure coil circuit

Controlling torque

$$T_c = K\theta$$

Where, K = spring constant, θ = final steady deflection

$$\text{Deflection, } \theta = \left(K_1 \frac{dM}{d\theta} \right) P$$

Where, P = Power being measured = $VI \cos \phi$, $K_1 = \frac{1}{R_p K}$

Note:

Scale is linear in terms of power as $\theta \propto P$

Errors in Electro-dynamometer Wattmeter Correction factor (K)

The correction factor is a factor by which the actual wattmeter reading is multiplied to get the true power.

For lagging power factor,
$$K = \frac{\cos \phi}{\cos \beta \cos(\phi - \beta)}$$

For leading power factor,
$$K = \frac{\cos \phi}{\cos \beta \cos(\phi + \beta)}$$

Where,

ϕ = Angle between current in the current coil and voltage of pressure coil

β = Angle between current and voltage of pressure coil

True power = Correction factor x actual wattmeter reading

For Very small β

Actual wattmeter reading = true power (1 + tan ϕ tan β)

Error = tan ϕ tan β x true power = VI sin ϕ tan β

%error = tan ϕ tan β x 100

True power = VI cos ϕ

Where, V = Voltage applied to pressure coil, I = Current in current coil

Power in Poly-Phase Systems

Blondel's Theorem

If a network is supplied through n conductors, the total power is measured by summing the reading of n wattmeters so arranged that a current element of a wattmeter is in each line and the corresponding voltage element is connected between that line and a common point, if the common point is located on one of the lines, then the power may be measured by (n - 1) wattmeters.

Two wattmeter method

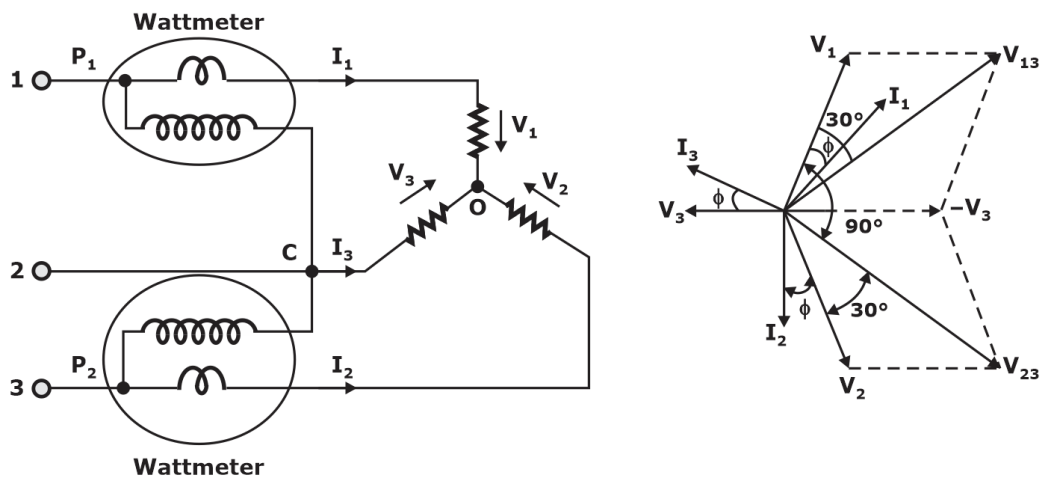

Reading of P₁ wattmeter, $P_1 = \sqrt{3} VI \cos(30^\circ - \phi)$

Reading of P₂ wattmeter, $P_2 = \sqrt{3} VI \cos(30^\circ + \phi)$

Total power consumed by load, $P = P_1 + P_2$

$$\text{Power factor, } \cos \phi = \cos \left[\tan^{-1} \left(\sqrt{3} \frac{P_1 - P_2}{P_1 + P_2} \right) \right]$$

$$\tan \phi = \sqrt{3} \frac{P_1 - P_2}{P_1 + P_2}$$

Where, V = Phase voltage, I = Phase current

ϕ = Angle between phase current and phase voltage

Reading of wattmeter at Different Power Factor

S.No.	ϕ	$\cos \phi$	P_1	P_2	$P = P_1 + P_2$	Comment
1.	0	1	$\frac{\sqrt{3}}{2} V_{LL}$	$\frac{\sqrt{3}}{2} V_{LL}$	$\sqrt{3} V_{LL}$	$P_1 = P_2$ (equal reading)
2.	30°	0.866	V_{LL}	$\frac{V_{LL}}{2}$	1.5 V_{LL}	$P_1 = 2P_2$
3.	60°	0.5	$\frac{\sqrt{3}}{2} V_{LL}$	0	$\frac{\sqrt{3}}{2} V_{LL}$	$P_2 = 0, P_1 = P$
4.	90°	0	$+\frac{V_{LL}}{2}$	$-\frac{V_{LL}}{2}$	0	$P_1 = -P_2$

Note:

When Wattmeter reading comes into negative, reverse either P.C. or C.C. terminal and then take the reading of negative wattmeter.

Measurement of Energy

For the measurement of energy, we use energy meter. Energy meter is an integrating instrument which adds the energy cumulatively over a period of time.

$$\text{Energy} = \text{Power} \times \text{time} = \int_0^t P \cdot dt \text{ kWhr}$$

Note:

Energy meter works on principle of induction.

- The meter which measure A.C. energy is called watt hour meter.
- The meter which measure D.C. energy is called amp-hour meter.

Deflection torque, $T_D \propto P$

Breaking torque, $T_B \propto N$

Where, N = Speed of disc in rps

At balance, $T_d = T_B$

$$\int P . dt = K \int N .dt$$

$$\text{Energy} \propto \int N .dt$$

Energy meter constant (EMC)

$$\text{EMC} = \frac{\text{Number of revolution made by disc}}{\text{Energy recorded in kWhr.}}$$

Where, P = Power in kW, T = Time in hrs.

$$\text{Revolution of disc due, \%Creeping Error} = \frac{\text{creeping per hour}}{\text{Revolution of disc due to total load per hour}} \times 100$$

Remember:

Potential coil of energy meter should be highly inductive so that it measures true energy.

Compensation in Energy meter

1. Lag compensation: Through lag coil or shading coil.
2. Low load or friction adjustment: By using shading loop.
3. Over friction or creeping: By providing holes or slots on rotating disc.
4. Overload compensation: By keeping saturable shunt magnet in series magnet or current coil.
5. Overvoltage compensation: By keeping saturable shunt magnet in shunt magnet.
6. Speed adjustment: By adjusting position of break magnet.

Remember:

Creeping error is always positive.

If either potential coil or current coil is wrongly connected then the disc rotates in opposite direction.

Chapter-4

Measurement of R, L & C (Resistors, Inductors, Capacitors)

Frequency Errors in Resistors

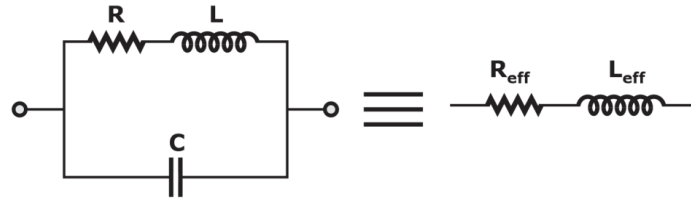

(Equivalent circuit of a resistor at low and medium frequencies)

Effective resistance

$$R_{\text{eff}} = \frac{R}{1 + \omega^2 C (CR^2 - 2L)}$$

Effective inductance or residual inductance

$$L_{\text{eff}} = \frac{L - CR^2}{1 + \omega^2 C (CR^2 - 2L)}$$

$$\tan \phi = \frac{X_{\text{eff}}}{R_{\text{eff}}} = \frac{\omega L_{\text{eff}}}{R_{\text{eff}}} = \frac{\omega (L - CR^2)}{R} = \omega \left(\frac{L}{R} - CR \right)$$

Where, ϕ = Phase deflection angle Time constant

Condition for resistance to remain independent of frequency, $CR^2 = 2L$

Condition for resistance to show no inductive effect, $CR^2 = L$

Effective resistance for zero effective inductance, $R_{\text{eff}} = \frac{R}{1 - \omega^2 LC}$

Quality factor, $Q = \frac{\omega L}{R}$

Frequency Error in Inductors

Effective resistance, $R_{\text{eff}} = \frac{R}{(1 - \omega^2 LC)}$

Effective inductance, $L_{\text{eff}} = L(1 + \omega^2 LC)$

Capacitor

1. Parallel Representation

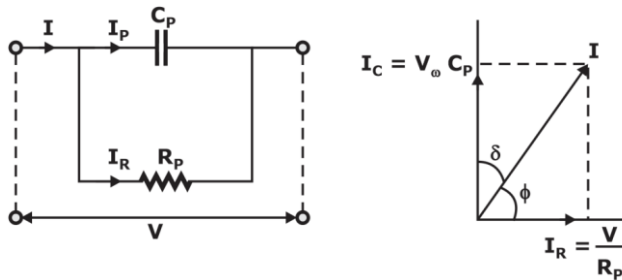

Dielectric loss, $P_L = \omega C_p V^2 \tan \delta$

Dissipation factor, $D = \tan \delta = \frac{1}{\omega C_p R_p}$

Where, δ = loss angle of the capacitor.

2. Series Representation

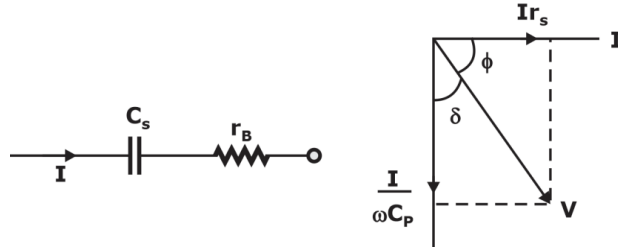

Dissipation factor, $P_L = \frac{I^2}{\omega C_s} \tan \delta$

Dissipation factor, $D = \tan \delta = \omega C_s r_s$

FREQUENCY Errors in Capacitors

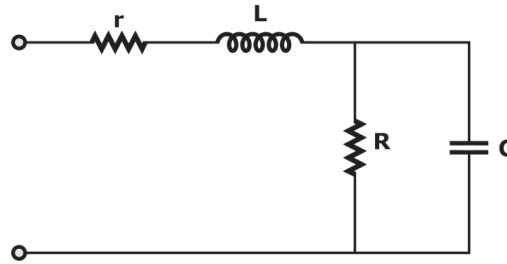

Equivalent circuit of a capacitor

Equivalent Circuit of a Capacitor

Effective capacitance, $C_{\text{eff}} = \frac{C}{1 - \omega^2 LC}$

1. For Medium Frequency

Effective capacitance, $C_{\text{eff}} = C(1 + \omega^2 LC)$

Effective series resistance, $R_{\text{eff}} = r + \frac{R}{1 + \omega^2 R^2 C^2}$

Where, r = resistance of load

Loss angle, $\tan \delta = \frac{1 - \omega^2 LC}{\omega r + \frac{1}{\omega CR}}$

2. For Low Frequency

Effective capacitance, $C_{\text{eff}} = C + \frac{1}{\omega^2 CR^2}$

Effective series resistance, $R_{\text{eff}} = \frac{R}{1 + \omega^2 C^2 R^2}$

Loss angle, $\tan \delta = \frac{1}{\omega CR}$

Classification of Resistance

1. Low resistance: All resistance of the order of 1Ω and below.
Example: Winding coils of electrical motors, generators and transformers.
2. Medium resistance: Resistances from 1Ω upwards to about $0.1 \text{ M}\Omega$.
Example: Resistance of heaters, potentiometers.
3. High resistance: All resistances of the order of $0.1 \text{ M}\Omega$ and above.
Example: Insulation of electrical cable and windings, insulation of motors, generators and transformers.

Measurement of Medium Resistance

The different methods employed are:

- | | |
|--------------------------------|-------------------------------|
| (i) Ammeter – voltmeter method | (ii) Wheatstone bridge method |
| (iii) Ohmmeter method | (iv) Substitution method |

1. Ammeter Voltmeter Method

$$R_m = \frac{\text{Voltmeter reading}}{\text{Ammeter reading}} = \frac{V}{I}$$

Where, R_m = measured value of resistance

(a) Circuit for higher resistance

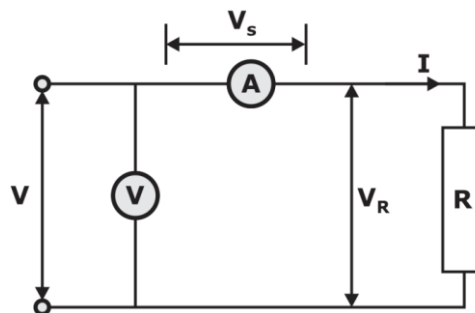

True value of resistance, $R = R_{m1} - R_a$

$$R_m = R_{m1} \left(1 - \frac{R_a}{R_{m1}} \right)$$

Where, R_{m1} = Measured value of resistance, R_a = Resistance of ammeter

Relative error

$$\epsilon_r = \frac{R_{m1} - R}{R} = \frac{R_a}{R}$$

To get minimum error, the test resistance should be more than the ammeter resistance so that this adjustment is suitable for measurement of high resistance.

(b) Circuit for lower resistance

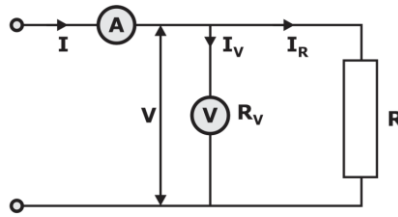

True value of resistance

$$R = \frac{R_{m2}R_v}{R_v - R_{m2}}$$

Where, R_{m2} = Measured value of resistance, R_v = Resistance of voltmeter

For $R_v \gg R_{m2}$

$$R = R_{m2} \left(1 - \frac{R_{m2}}{R_v} \right)$$

Relative error, $\epsilon_r = \frac{R_{m2} - R}{R} = \frac{-R_{m2}^2}{R_v R}$ $[R_v \gg R_{m2}]$

Approximate relative error, $\epsilon = -\frac{R}{R_v}$ $[for R_{m2} \approx R]$

Note:

Relative errors for above two cases are equal when true value of resistance,

$$R = \sqrt{R_a R_v}$$

2. Wheatstone Bridge

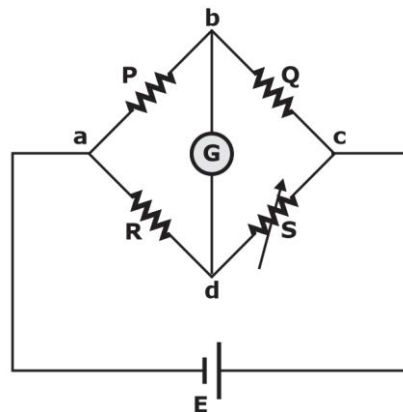

At balance, $R = S \frac{P}{Q}$

Sensitivity of Wheatstone bridge, $S_B = \frac{\theta}{\Delta R / R} = \frac{S_v E S R}{(R + S)^2}$; $mm = \frac{S_v E}{\frac{P}{Q} + 2 + \frac{Q}{P}}$

Where,

S_v = Voltage sensitivity of galvanometer, mm/volt

E = Bridge voltage

P, Q = Branch resistances

θ = Deflection of galvanometer, mm

For a bridge with equal arms, $S_B = \frac{S_V E}{4}$

Note:

- For maximum bridge sensitivity

$$\frac{P}{Q} = \frac{R}{S} = 1$$

- Sensitivity of bridge is most important parameter as compared to accuracy, precision and resolution.

Equivalent circuit of Wheatstone bridge

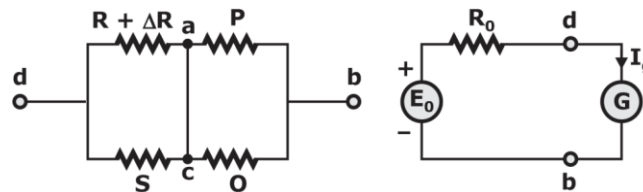

Galvanometer current, $I_g = \frac{E_0}{R_0 + G}$

Where,

E_0 = Thevenin's or open circuit voltage appearing between terminals b and d with galvanometer circuit open circuited.

G = Resistance of the galvanometer circuit

$E_0 = E \left[\frac{R + \Delta R}{2R + \Delta R} - \frac{1}{2} \right] \approx E \left(\frac{\Delta R}{4R} \right)$ as $\Delta R \ll R$

ΔR = Change in resistance R

Thevenin equivalent resistance of bridge, $R_0 = \frac{RS}{R + S} + \frac{PQ}{P + Q}$

Galvanometer deflection, $\theta = \frac{S_V E S \Delta R}{(R + S)^2} = \frac{S_i E S \Delta R}{(R_0 + G)(R + S)^2}$

Where,

S_i = Current sensitivity of galvanometer Bridge sensitivity

$S_B = \frac{\theta}{\Delta R / R} = \frac{S_i E S R}{(R_0 + G)(R + S)^2}$

Current sensitivity

$$S_i = \frac{\theta}{I_g} ; \text{mm}/\mu\text{A}$$

θ = Deflection in galvanometer

I_g = Current in galvanometer voltage sensitivity

$$S_V = \frac{\theta}{V_{Th}} ; \text{mm}/\text{V}$$

V_{Th} = Voltage across galvanometer

Note:

In Wheatstone bridge method, the effect of lead resistance is not eliminated hence it is not suitable for measurement of low resistance.

3. Ohmmeters

(a) Series Type ohmmeter

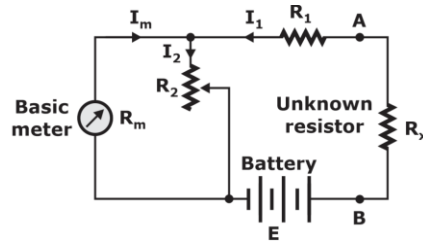

Half scale resistance, $R_h = R_1 + \frac{R_2 R_m}{R_2 + R_m}$

Meter current, $I_m = \frac{E R_2}{(R_h + R_x)(R_2 + R_m)}$

Full scale deflection current, $I_{fs} = \frac{E R_2}{R_h (R_2 + R_m)}$

Friction of full scale reading, $S = \frac{I_m}{I_{fs}} = \frac{R_m}{R_x + R_h}$

(b) Shunt Type Ohmmeter

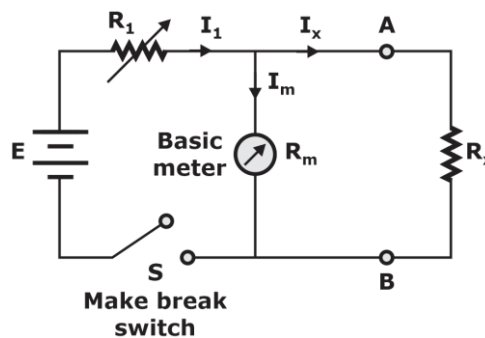

Half scale reading of unknown resistance R_x is

$$R_h = \frac{R_1 R_m}{R_1 + R_m}$$

Half scale reading of the meter, $I_h = 0.5 I_{fs} = \frac{E R_h}{R_1 R_m + R_h (R_1 + R_m)}$

Where, R_m = Internal resistance of meter, R_1 = Adjustable resistor (as shown in figure)

E = Supply voltage

Measurement of low Resistance

The different methods employed are:

- (i) Kelvin’s double bridge method
- (ii) Ammeter voltmeter method
- (iii) Potentiometer method

Kelvin’s Double Bridge Method

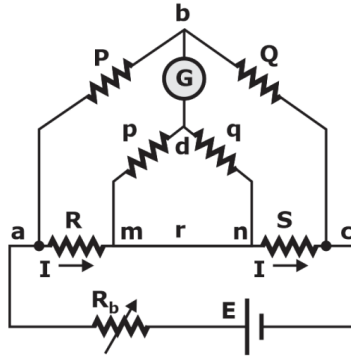

For zero galvanometer deflection, $E_{ab} = E_{amd}$

$$R = \frac{P}{Q} \cdot S + \frac{qr}{p+q+r} \left[\frac{P}{Q} - \frac{p}{q} \right]$$

$$\text{If } \frac{P}{Q} = \frac{p}{q}$$

$$\text{Then } R = \frac{P}{Q} \cdot S$$

Note:

Accuracies by Kelvin double bridge method

- (i) From $1000 \mu\Omega$ to 1.0Ω : 0.005%,
- (ii) From $100 \mu\Omega$ to $1000 \mu\Omega$: 0.05% to 0.05%
- (iii) From $10 \mu\Omega$ to $100 \mu\Omega$: 0.5% to 0.2%

Measurement of High Resistance

The difference methods employed are:

- (i) Loss of charge method
- (ii) Megger
- (iii) Direct deflection method
- (iv) Mega ohm bridge

1. Loss of charge Method

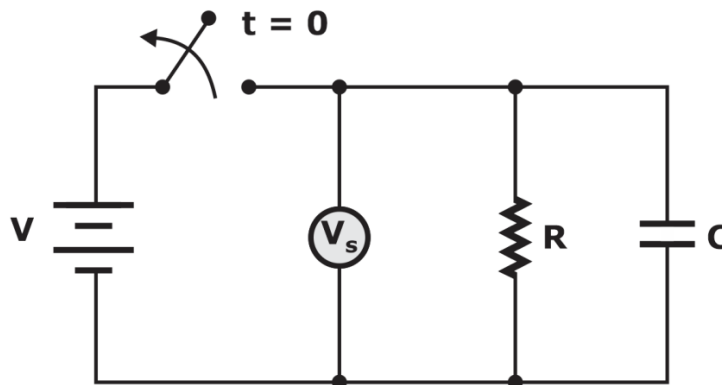

$$R = \frac{0.4343t}{C \log_{10} \left(\frac{V}{V_C} \right)}$$

2. Megger

- Megger works on the principle of electro-dynamometer.
- Megger is used to measure the insulation resistance of cable, motor and generator, etc.
- Deflecting torque angle is proportional to the resistance of the insulator, which is under test.
- It is also used to check the continuity of cable.
- No external control torque provided. Air friction damping is used.
- No need of external power supply.

Note:

High resistance have a guard terminal which is used to avoid leakage current.

Carry Foster Slide Wire Bridge

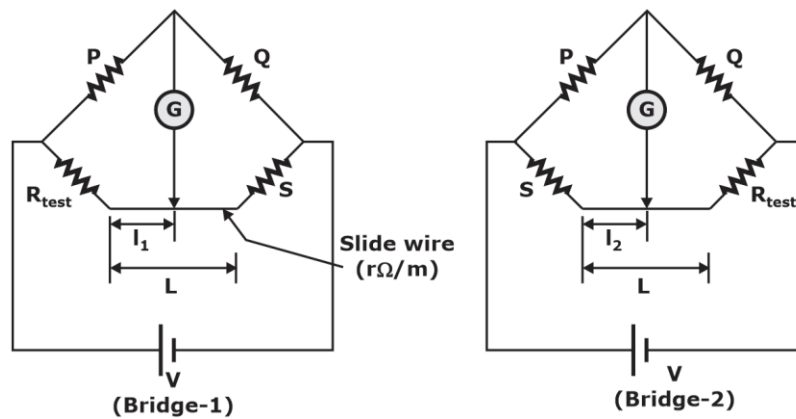

From bridge (1), $\frac{P}{Q} + 1 = \frac{R + S + Lr}{S + (L - l_1)r}$... (i)

From bridge (2), $\frac{P}{Q} + 1 = \frac{R + S + Lr}{R + (L - l_2)r}$... (ii)

Equating equation (i) and (ii)

$$R - S = (l_2 - l_1)r$$

Note:

Carry Foster bridge method is used for medium resistance measurement by comparing with standard resistance.

A.C. Bridges:-

Used to measure self-inductance, Mutual inductance, capacitance, and frequency.

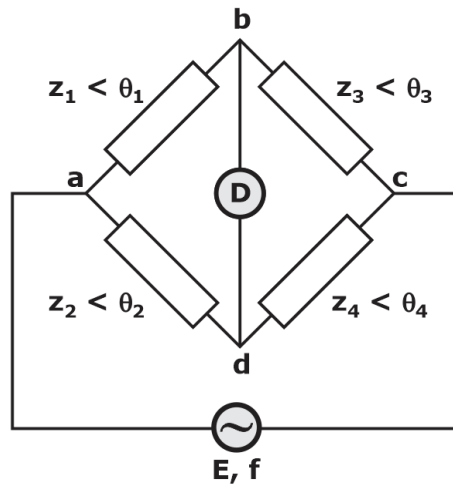

General Equation for bridge balance, $\bar{z}_1 \bar{z}_4 = \bar{z}_2 \bar{z}_3$

Magnitude condition, $|z_1| |z_4| = |z_2| |z_3|$

Angle condition, $\angle \theta_1 + \angle \theta_4 = \angle \theta_2 + \angle \theta_3$

Note:

Magnitude condition and angle condition both must be satisfied for the bridge to be balanced.

Depending upon the frequency, different null detectors are used.

Vibration galvanometer - 5 Hz to 1 kHz

Head phones - 250 Hz to 4 kHz

Tuned amplifier detector - 10 Hz to 100 kHz

D'Arsonval Galvanometer -DC frequency=0 Hz

Depending upon Phase angle θ , elements are

θ	Elements
0°	R
90°	L_1
-90°	C_1
$0^\circ < \theta_1 < 90^\circ$	R_1, L_1
$-90^\circ < \theta_1 < 0^\circ$	R_1, C_1

Convergence to balance point:

If the variables are in the same arm of bridge then minimum time is required for balancing of bridge. This is called convergence to balance point.

Quality factor (Q.F.), $Q.F. = \frac{\text{Energy Stored}}{\text{Energy dissipated}}$

Measurement of Self Inductance

1. Maxwell's Inductance Bridge

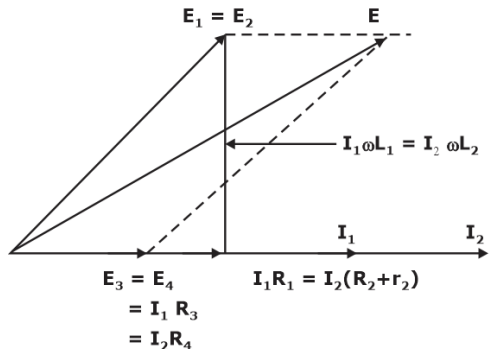
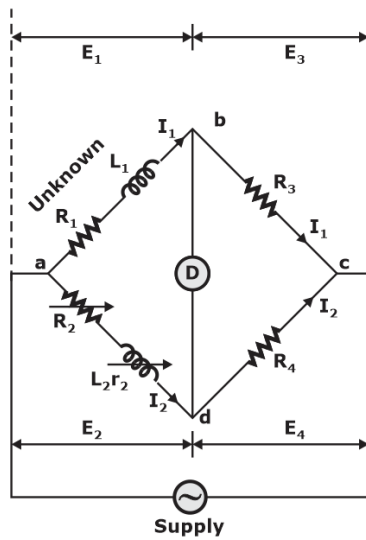

$$R_1 = \frac{R_3}{R_4} (R_2 + r_2), \quad L_1 = \frac{R_3}{R_4} \cdot L_2$$

Where,

L_1 = Unknown inductance of resistance R_1

L_2 = Variable inductance of fixed resistance r_2

R_2 = Variable resistance connected in series with L_2

R_3, R_4 = Known non-inductive resistance

2. Maxwell's Inductance-capacitance Bridge

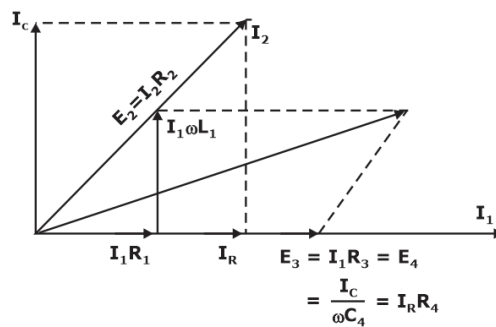
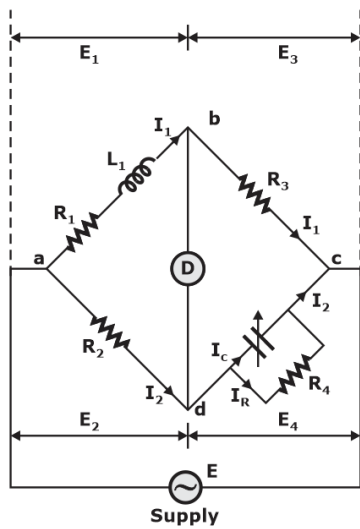

$$R_1 = \frac{R_2 R_3}{R_4} \quad \text{and} \quad L_1 = R_2 R_3 C_4$$

$$Q \text{ factor of the coil, } Q = \frac{\omega L_1}{R_1} = \omega C_4 R_4$$

Note:

- Not suitable for measurement of high Q coil because phase angle criteria does not satisfy.
- Not suitable for measurement of low Q-coil because of sliding balance problem.
- Suitable for measurement of medium Q coil i.e. ($1 < Q < 10$).

3. Hay's Bridge

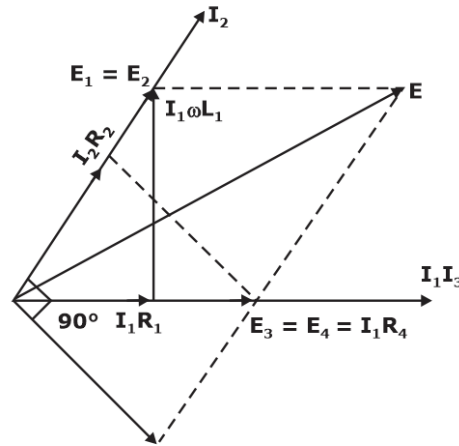
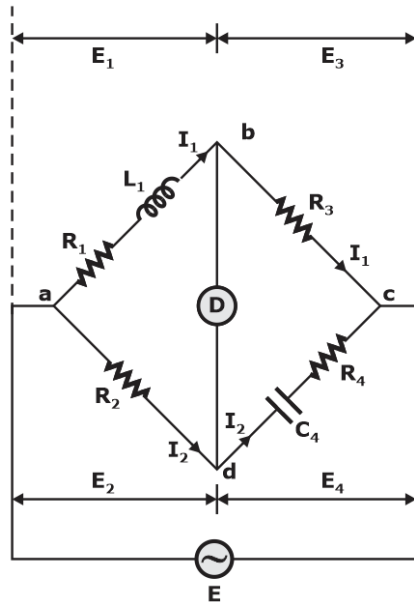

$$R_1 = \frac{\omega^2 R_2 R_3 R_4 C_4^2}{1 + \omega^2 C_4^2 R_4^2} = \frac{R_2 R_3}{R_4} \left(\frac{1}{1 + Q^2} \right)$$

$$L_1 = \frac{R_2 R_3 C_4}{1 + \omega^2 C_4^2 R_4^2} = \frac{R_2 R_3 C_4}{1 + \left(\frac{1}{Q} \right)^2}$$

For $Q > 10$

$$L_1 = R_2 R_3 C_4$$

$$Q = \frac{\omega L_1}{R_1} = \frac{1}{\omega C_4 R_4}$$

Where, L_1 = Unknown-inductance having a resistance R_1

R_2, R_3, R_4 = Know non-inductive resistance

C_4 = Standard capacitor

Note: The Hay's bridge is suited for the measurement of high Q inductors.

4. Anderson's Bridge

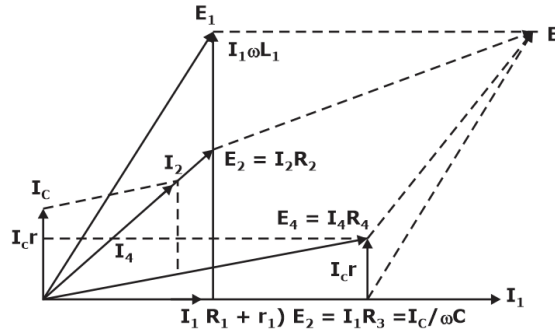
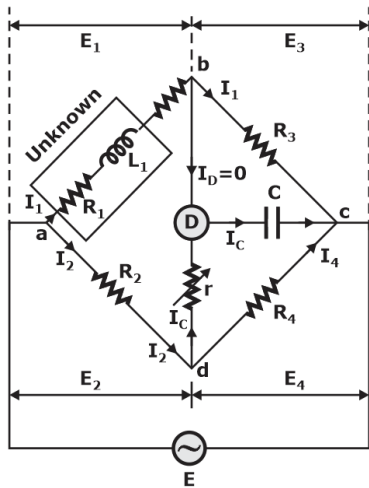

$$R_1 = \frac{R_2 R_3}{R_4} - r_1$$

$$L_1 = \frac{C R_3}{R_4} [r(R_4 + R_2) + R_2 R_4]$$

Where, L_1 = Self-inductance to be measured

R_1 = Resistance of self-inductor

r_1 = Resistance connected in series with self-inductor

r, R_2, R_3, R_4 = Known non-inductive resistances

C = Fixed standard capacitor

5. Owen's Bridge

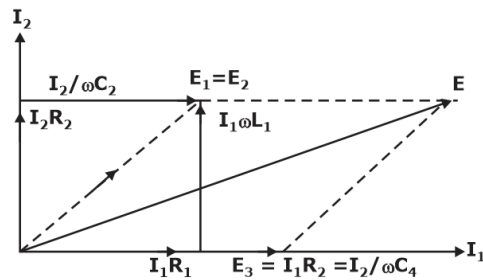
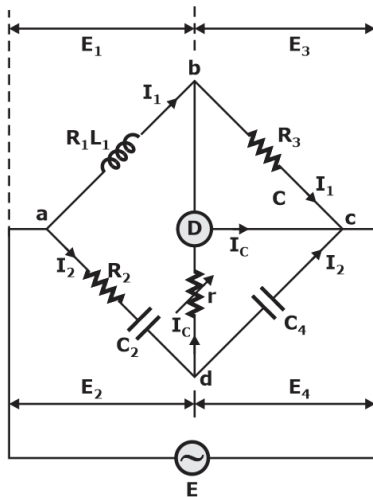

$$L_1 = R_2 R_3 C_4$$

$$R_1 = R_3 \frac{C_4}{C_2}$$

Where,

L_1 = Unknown self-inductance of resistance R_1

R_2 = Variable non-inductive resistance

R_3 = Fixed non-inductive resistance

C_2 = Variable standard capacitor

C_4 = Fixed standard capacitor

Note:

Owen's bridge is used for measurement of unknown inductance and incremental inductance and incremental permeability (μ).

Measurement of Incremental Inductance

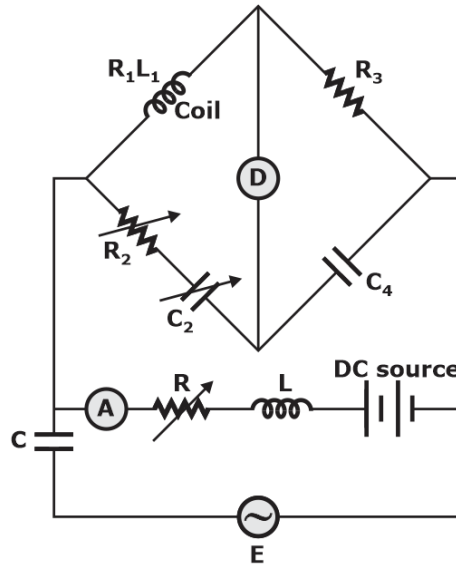

Incremental inductance, $L_1 = R_2 R_3 C_4$

Incremental permeability, $\mu = \frac{L_1 i}{N^2 A}$

Where,

N = Number of turns

A = Area of flux path

l = Length of flux path

R_2 = Variable non-inductive resistance

R_3 = Fixed non-inductive resistance

C_4 = Fixed standard capacitor

Note:

- External D.C. Source is used to compensate residual magnetism.
- Capacitor, C is to block D.C. to enter into A.C. and inductor, L is to block A.C. to enter into D.C.

Measurement of Capacitance

1. De Sauty's Bridge

(a) For lossless capacitor

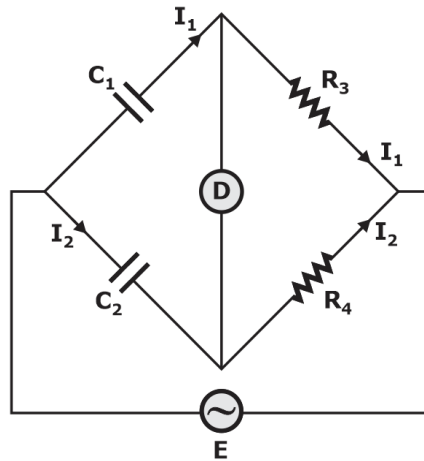

$$C_1 = \frac{C_2 R_4}{R_3}$$

Where,

C_1 = Capacitor whose Capacitance to be measured

C_2 = A Standard capacitor

R_3, R_4 = Non-inductive resistors

(b) For imperfect capacitor having dielectric loss

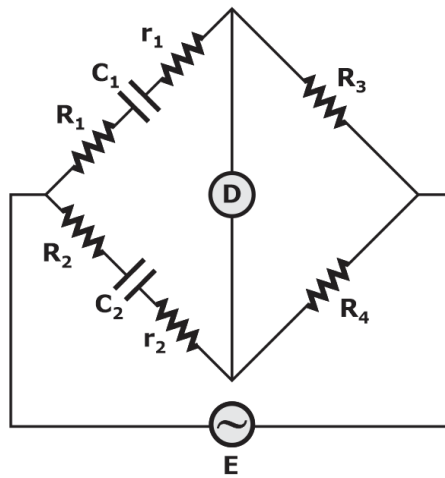

$$\frac{C_1}{C_2} = \frac{R_4}{R_3} = \frac{R_2 + r_2}{R_1 + r_1}$$

Where,

r_1, r_2 = Resistance representing the loss component of the two capacitor.

Dissipation factor

$$D = \tan \delta = \omega C_1 r_1 = \omega C_2 r_2$$

2. Schering Bridge

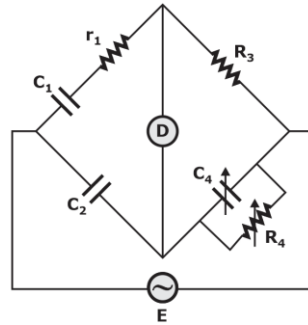

$$r_1 = \frac{R_3 C_4}{C_2}$$

$$C_1 = r_1 C_2 \left(\frac{R_4}{R_2} \right)$$

Dissipation factor

$$D = \omega C_1 r_1 = \omega C_2 R_2$$

Where,

C_1 = capacitor whose capacitance is to be determined

r_1 = Series resistance representing the loss in the capacitor C_1

C_2 = Standard loss-free capacitor

R_3 = Non-inductive resistance

C_4 = Variable capacitor

R_4 = Variable non-inductive resistance in parallel with variable capacitor C_4

Note: Schering bridge is shielded with metal screen to reduce the stray capacitance exists between the arms and arms to the earth.

Measurement of Frequency

Wien's Bridge

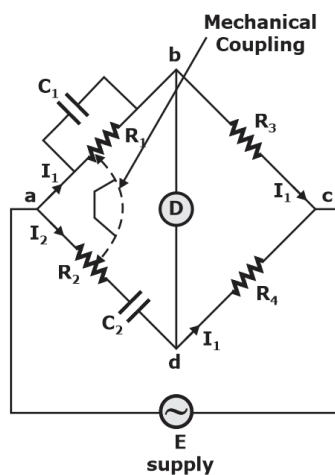

Frequency

$$\frac{R_4}{R_3} = \frac{R_2}{R_1} + \frac{C_1}{C_2}$$

$$f = \frac{1}{2\pi\sqrt{R_1 R_2 C_1 C_2}} \text{ Hz}$$

For $R_1 = R_2 = R$ and $C_1 = C_2 = C$

$$f = \frac{1}{2\pi RC}$$

$$\frac{R_4}{R_3} = 2$$

Limitation of Wein's Bridge

If the input signal is not a sinusoidal or signal containing harmonics then balancing of bridge is not possible because null detector is sensitive to the frequencies.

Q-meter

It works on the principle of series resonance.

Measurement of the Storage Factor Q

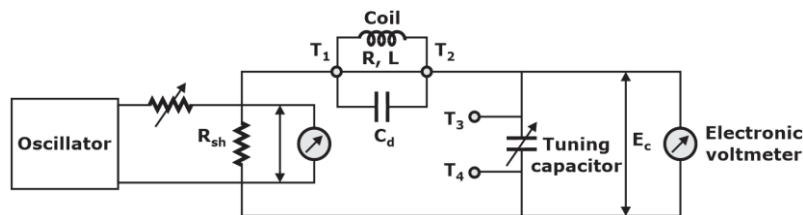

Resonant frequency of Q-Meter, $f_0 = \frac{1}{2\pi\sqrt{LC}}$

Measured value of Q, $Q_m = \frac{\omega_0 L}{R + R_{sh}}$

True value of Q, $Q_t = \frac{\omega_0 L}{R} = Q_m \left(1 + \frac{R_{sh}}{R}\right) = Q_m \left(1 + \frac{C_d}{C}\right)$

Where, R = Resistance of coil, L = Inductance of coil, R_{sh} = Shunt resistance
 C = Tuning Capacitance, C_d = Distributed or self-capacitance

Measurement of inductance, $L = \frac{1}{4\pi^2 f_0^2 C}$

Measurement of effective resistance, $R = \frac{\omega_0 L}{Q_t}$

Measurement of Distributed or self-capacitance

Resonance frequency, $f_1 = \frac{1}{2\pi\sqrt{L(C_1 + C_d)}}$, $f_2 = \frac{1}{2\pi\sqrt{L(C_2 + C_d)}}$

When, $f_2 = n f_1$ then, $C_d = \frac{C_1 - n^2 C_2}{n^2 - 1}$

where, C_1 = Tuning capacitance at frequency f_1 , C_2 = Tuning capacitance at frequency f_2

Measurement of Unknown Capacitance C_x

Adjust capacitor $C = C_1$ to get resonance frequency f_1 with unknown capacitance C_x in parallel.

$$f_1 = \frac{1}{2\pi\sqrt{L(C_x + C_1)}} \quad \dots(i)$$

Now remove C_x and again adjust $C = C_2$ to get same resonance frequency f_1

$$f_1 = \frac{1}{2\pi\sqrt{LC_2}} \quad \dots(ii)$$

By equating equation (i) and (ii)

$$C_x = C_2 - C_1$$

Chapter-5

Digital Instruments & Instrument Transformers

Cathode Ray Oscilloscope

CRO is a digital instrument, which works on the principle of thermionic emission i.e. emission of electron from a heated surface. It is a linear device. With the use of CRO, one can measure peak to peak, rms, peak or average value of voltage and current.

Calibration of CRO

Calibration of CRO is done by applying a known quality of square signal.

The rise time (t_r), of signal applied to CRO and bandwidth of CRO are related as

$$t_r \times \text{B.W.} = 0.35$$

If this condition fails, then the signal is distorted at the output of CRO.

Electrostatic Deflection

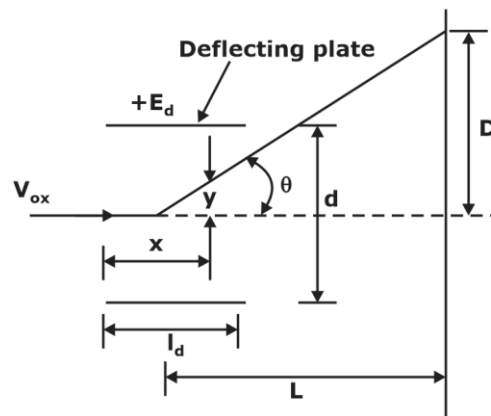

$$y = \frac{1}{2} \frac{eE_y}{mv_{ox}^2} x^2$$

where, y = Displacement in y -direction; m , e = Charge of an electron; Coulomb

E_y = Electric field intensity in Y -direction; V/m , m = Mass of electron; kg

V_{ox} = Velocity of electron when entering the fields of deflecting plates; m/s

x = Displacement in x -direction; m

Deflection

$$D = \frac{L l_d E_d}{2dE_a}$$

Where,

L = Distance between screen and the center of deflecting plates; m

l_d = Length of deflecting plates; m,

E_d = Potential between deflecting plates; V

d = Distance between deflecting plates; m,

E_a = Voltage of pre-accelerating anode; V

Deflection sensitivity:

$$S = \frac{D}{E_d} = \frac{L l_d}{2dE_a} \text{ m / v}$$

Deflection factor:

$$G = \frac{1}{S} = \frac{2dE_a}{L l_d} \text{ v / m}$$

Sawtooth Generator:

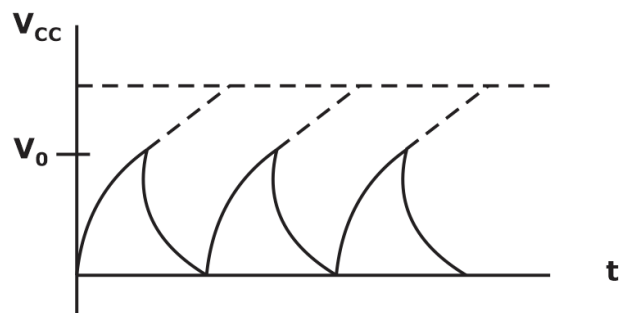
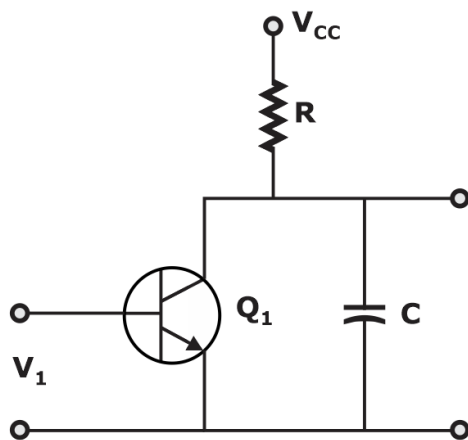

$$V_0 = V_{cc} [1 - \exp(-t/RC)]$$

Where,

V_0 = Instantaneous voltage across the capacitor at time t; V_{cc} = Supply voltage

Lissajous patterns

If horizontal and vertical deflecting plate are applied with sinusoidal signal, the waveform pattern appearing on the screen is called Lissajous pattern.

Application

- Used for finding the phase angle difference between the signal applied to vertical and horizontal plate.
- Used for finding the frequency ratio between vertical and horizontal plates voltage.

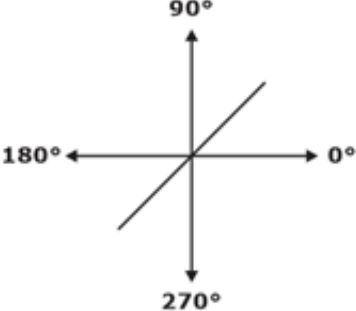
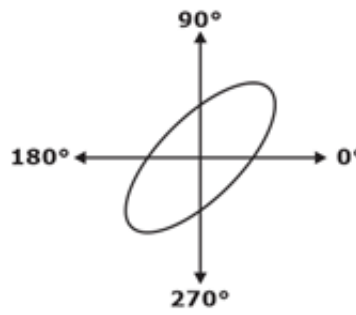
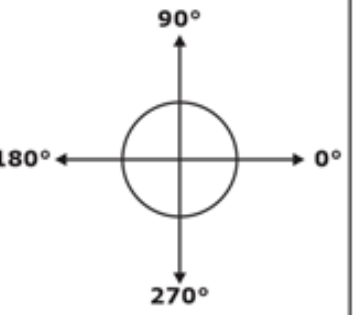
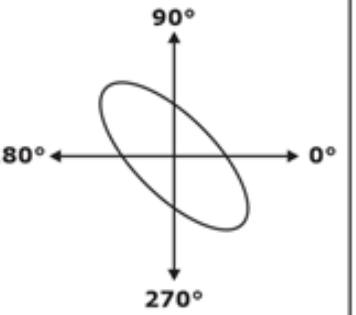
Phase angle (ϕ), between V_x and V_y	Lissajous pattern
0° or 360°	
$0^\circ < \phi < 90^\circ$ or $270^\circ < \phi < 360^\circ$	
$\phi = 90^\circ$ or 270°	
$90^\circ < \phi < 180^\circ$ or $180^\circ < \phi < 270^\circ$	

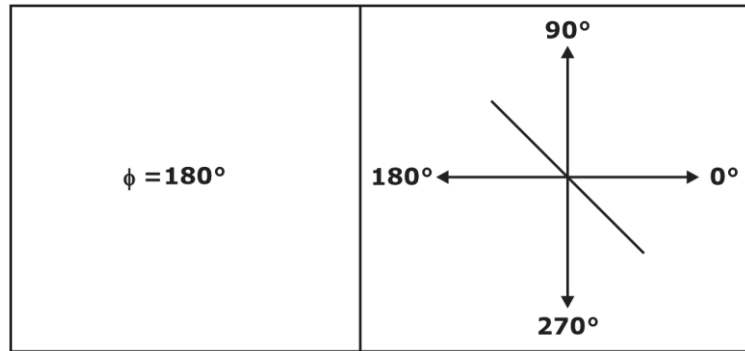

Finding the phase angle ϕ from given Lissajous pattern

(a) When Lissajous pattern is in first and third quadrant

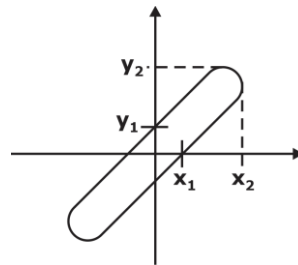

First possibility, $\phi = \sin^{-1}\left(\frac{x_1}{x_2}\right) = \sin^{-1}\left(\frac{y_1}{y_2}\right)$

Second possibility = $360^\circ - \phi$

(b) When Lissajous pattern is in second and fourth quadrant

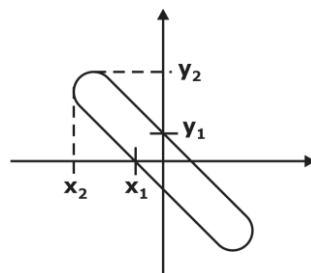

First possibility

$\phi = 180^\circ - \sin^{-1}\left(\frac{x_1}{x_2}\right)$

Second possibility = $360^\circ - \phi$

Measurement of Frequency Using Lissajous Pattern

$$\frac{f_y}{f_x} = \frac{\text{(number of intersections of the horizontal line with the curve)}}{\text{(number of intersections of the vertical line with the curve)}}$$

Where,

f_y = Frequency of signal applied to Y plates

f_x = Frequency of signal applied to X plates

Digital Meters

Basic measurable quantity in digital meter is D.C.

1. Resolution (R) of Digital Meter

The smallest change in the input which a digital meter can be able to detect is called resolution.

$$R = \frac{1}{10^n}$$

Where, n = Number of full digit.

2. Sensitivity (S)

The smallest change in input that can be displayed within given range.

$$S = \text{Resolution} \times \text{Range of meter}$$

3. Over ranging

Switch on the extra half (1/2) is called over ranging. Due to this over ranging, the range of the instrument increases.

Instrument Transformers

Ratios of Instrument Transformers:

1. Transformation Ratio (R)

It is the ratio of the magnitude of the primary phasor to the secondary phasor.

$$R = \frac{|\text{primary phasor}|}{|\text{secondary phasor}|}$$

$$\text{For current transformer (C.T.), } R = \frac{\text{primary winding current}}{\text{secondary winding current}}$$

$$\text{For potential transformer (P.T.), } R = \frac{\text{primary winding voltage}}{\text{secondary winding voltage}}$$

2. Nominal Ratio (K_n)

It is the ratio of rated primary winding current (or voltage) to the rated secondary winding current (or voltage)

$$\text{For C.T., } K_n = \frac{\text{rated primary winding current}}{\text{rated secondary winding current}}$$

$$\text{For P.T., } K_n = \frac{\text{rated primary winding voltage}}{\text{rated secondary winding voltage}}$$

3. Turns Ratio (n)

For C.T., $n = \frac{\text{number of turns of secondary winding}}{\text{number of turns of primary winding}}$

For P.T, $n = \frac{\text{number of turns of primary winding}}{\text{number of turns of secondary winding}}$

4. Ratio Correction Factor:

$$\text{RCF} = \frac{R}{K_n}$$

Remember:

The ratio marked on the transformers is their nominal ratio.

Current Transformer Equivalent Circuit

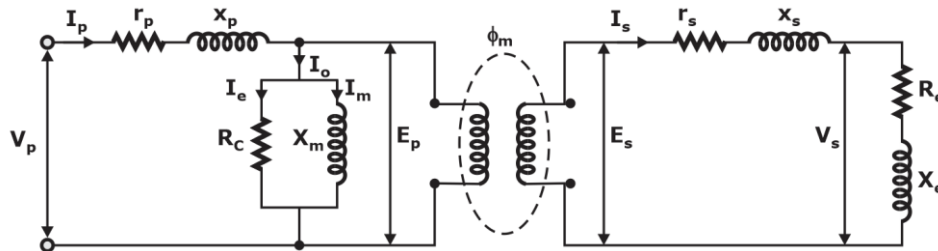

Where,

r_s, X_s = resistance, reactance of secondary winding

r_e, X_e = resistance, reactance of external burden

E_p, E_s = primary and secondary winding induced voltage

N_p, N_s = number of primary and secondary winding turns

I_p, I_s = primary and secondary winding current

ϕ = flux in transformer

θ = phase angle of transformer

δ = angle between secondary winding induced voltage and secondary winding current

Δ = phase angle of secondary winding load circuit

I_o = exciting current

I_m = magnetizing component of exciting current

I_e = loss component of exciting current

α = angle between exciting current and flux

Phasor Diagram

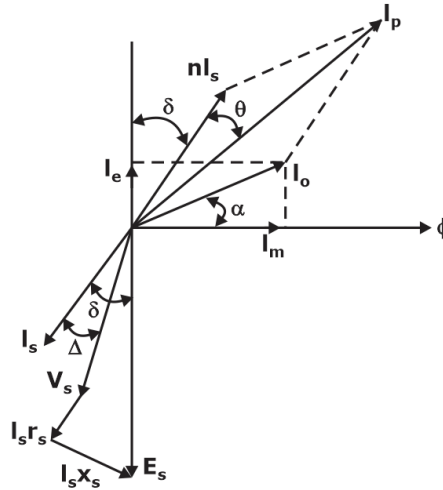

Transformation ratio

$$R = \frac{I_p}{I_s} = \frac{nI_s + I_0 \cdot \sin(\delta + \alpha)}{I_s} = n + \frac{I_0}{I_s} \sin(\delta + \alpha)$$

$$R = n + \frac{I_0}{I_s} \sin(\delta + \alpha) = n + \frac{I_0}{I_s} (\sin \delta \cos \alpha + \cos \delta \sin \alpha)$$

$$R = n + \frac{I_M \sin \delta + I_C \cos \delta}{I_s}$$

Where, $I_m = I_0 \cos \alpha$

$I_c = I_0 \sin \alpha$

Phase angle

For very small angles, $\theta \approx \frac{I_0 \cdot \cos(\delta + \alpha)}{nI_s + I_0 \cdot \sin(\delta + \alpha)}$

This expression can still be simplified with the assumption $I_0 \ll nI_s$.

$$\theta \approx \frac{I_0 \cdot \cos(\delta + \alpha)}{nI_s} \text{ rad}$$

$$\theta \approx \frac{I_0(\cos \delta \cos \alpha - \sin \delta \sin \alpha)}{nI_s} \approx \frac{I_M \cos \delta - I_C \sin \delta}{nI_s} \text{ rad}$$

Phase angle of CT is given by

$$\theta \approx \frac{180}{\pi} \left(\frac{I_M \cos \delta - I_C \sin \delta}{nI_s} \right) \text{ degrees}$$

Ratio error

$$\text{Ratio error} = \frac{\text{nominal ratio } (K_n) - \text{actual ratio } (R)}{\text{actual ratio } (R)}$$

Remember:

- The primary current of C.T is depending on load connected to system but it does not depend on the secondary winding burden.
- Primary winding is single turn or bar winding and secondary has more number of turns to reduce the current in secondary.
- If primary current is very high, it causes reduction in ratio error and phase angle error. So to increase value of primary current the primary is maintained with single turn.
- The secondary number of turns are reduced by 1 or 2 turns, then the ratio error reduces.

Potential transformer

Actual transformation (voltage) ratio

$$R = n + \frac{I_s}{n} \frac{[R_p \cos \Delta + X_p \sin \Delta] + I_e r_p + I_m X_p}{V_s}$$

Phase angle

$$\theta = \frac{I_s}{V_s} (X_s \cos \Delta - R_s \sin \Delta) + \frac{I_e X_p - I_m r_p}{n V_s} \text{ rad.}$$

Note:

- C.T never operates with secondary winding open but P.T can be operated with secondary winding open.
- Strip wound core is used to reduce ratio error and phase angle error.

Application of C.T and P.T

- Multiple operation with a single device.
- High current and higher voltage are step down to lower current and lower voltage so that metering is easier.
- Measuring circuit is isolated from the power circuit.
- Low power consumption.
- Replacement is easier.

Potentiometer

1. Zero Order System

As input changes, output also changes immediately called zero order system. Examples: Resistor.

2. First Order System

As input changes, output also changes but not immediately, it takes some delay but without oscillation. Example: heater.

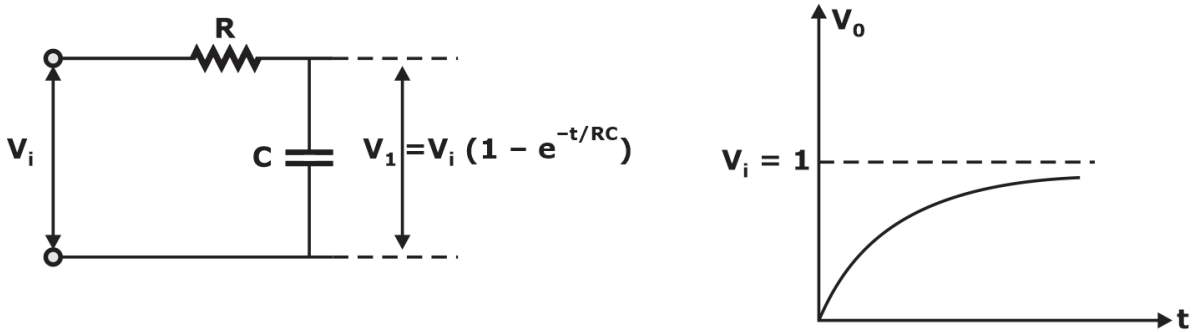

3. Second Order system

As input changes, output also changes, with some delay and oscillation.

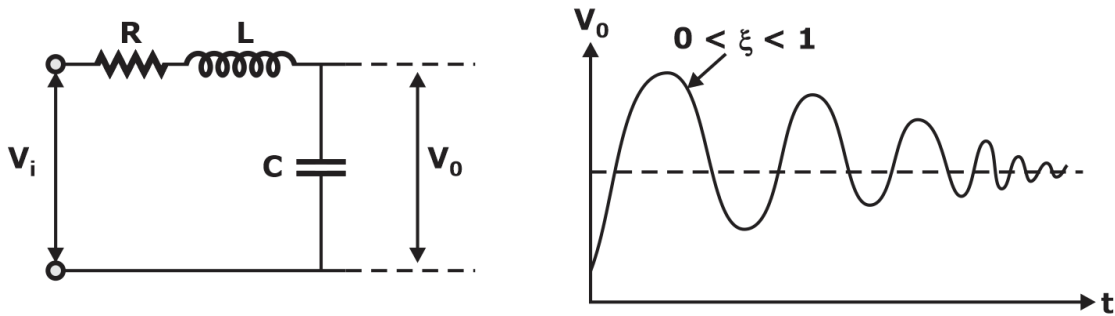

Remember:

The analog instruments are of second order instrument which has damping factor (ξ) between 0.6 to 0.8. It is under damped

Standards

Quantity	Unit	Definition
Length	Meter	The length of path travelled by light in an interval of $\frac{1}{299792458}$ sec. 9.192631770 \times 10 ⁹ cycles of radiation from vaporized cesium-133 atom.
Time	Second	The temperature difference between the absolute and the triple point of water is defined as 273.16°K.
Temp.	Kelvin	Standard cell voltage of Weston cell i.e., 1.0186 V.
Voltage	Volt	One ampere is the current flowing through two infinite cross section placed 1 meter apart produced a force of 2×10^{-7} N/m.
Current	Ampere	

Magnetic Measurements

Flux density

$$B = \frac{\phi}{A_s} = \frac{RK_q\theta_1}{2NA_s}$$

Where, ϕ = Flux linking search coil, A_s = Cross-sectional area of specimen,

R = Resistance of the ballistic galvanometer circuit

$K_q\theta_1$ = Charge indicated by ballistic galvanometer

N = Number of turns in the search coil Hysteresis loss per unit volume, $P_h = \eta f B_m k$

Where, η = Hysteresis coefficient, f = Frequency; Hz, B_m = Maximum flux density; Wb/m²

k = Steinmetz coefficient

Note: The value of k varies from 1.6 to 2.

$$\text{Eddy current loss per unit volume for laminations, } P_e = \frac{4k_f^2 f^2 B_m^2 t^2}{2\rho}$$

Where, k_f = Form factor, t = Thickness of laminations; m, ρ = Resistivity of material; Ω -m

$$\text{Total iron loss per unit volume, } p_1 = p_h + p_e = \eta f B_m k + \frac{4k_f^2 f^2 B_m^2 t^2}{3\rho}$$

$$\text{Maximum flux density, } B_m = \frac{E_2}{4k_f f A_s N_2}$$

$$\text{For sinusoidal supply, } B_m = \frac{E_2}{4.44 f A_s N_2}$$

Where, E_2 = Voltage induced in secondary winding, $E_2 = 4k_f f \phi_m N_2$

K_f = Form factor (= 1.11 for sinusoidal), f = Frequency

A_s = Cross-sectional area of specimen, N_2 = Number of turns in secondary winding

ϕ_m = Maximum flux linkage
