

GATE 2020

Set-2

Mechanical Engineering

Questions



SECTION: GENERAL APTITUDE

1. While I agree _____ his proposal this time, I do not often agree _____ him.
A. to, to B. with, with
C. with, to D. to, with
2. The recent measures to improve the output would _____ the level of production to our satisfaction.
A. speed B. decrease
C. increase D. equalise
3. Select the word that files the analogy:
White: Whitening:: Light: _____
A. Lighting B. Enlightening
C. Lightening D. Lightning
4. In one of the greatest innings ever seen in 142 years of Test history, Ben Stokes upped the tempo in a five-and-a-half hour long stay of 219 balls including 11 fours and 8 sixes that saw him finish on a 135 not out as England squared the five-match series.
Based on their connotations in the given passage, which one of the following meanings does not match?
A. tempo = enthusiasm
B. squared = lost
C. saw = resulted in
D. upped = increased
5. There are five levels {P,Q,R,S,T} in a linear supply chain before a product reaches customers, as shown in the figure.



At each of the five levels, the price of the product is increased by 25%. If the product is produced at level P at the cost of Rs. 120 per unit, what is the price paid (in rupees) by the customers?

- A. 234.38 B. 292.96
C. 187.50 D. 366.21
6. Climate change and resilience deal with two aspects – reduction of non-renewable energy resources and reducing vulnerability of climate change aspects. The terms 'mitigation' and 'adaption' are used to refer to these aspects, respectively.
Which of the following assertions is best supported by the above information?
A. Mitigation deals with consequences of climate change.
B. Mitigation deals with actions taken to reduce the use of fossil fuels.
C. Adaptation deals with causes of climate change.
D. Adaptation deals with actions taken to combat green-house gas emissions.
7. An engineer measures THREE quantities X, Y and Z in an experiment. She finds that they follow a relationship that is represented in the figure below: (the product of X and Y linearly varies with Z).

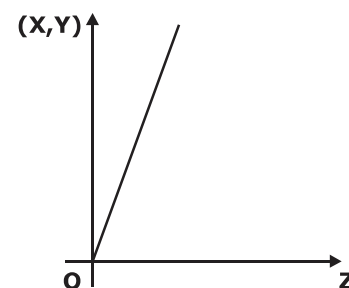

- Then, which of the following statements is FALSE?
- A. For fixed X; Z is proportional to Y
 - B. For fixed Z; X is proportional to Y
 - C. XY/Z is constant
 - D. For fixed Y; X is proportional to Z

8. It was estimated that 52 men can complete a strip in a newly constructed highway connecting cities P and Q in 10 days. Due to an emergency, 12 men were sent to another project. How many number of days, more than the original estimate, will be required to complete the strip?

- A. 3 days
- B. 10 days
- C. 5 days
- D. 13 days

9. Find the missing element in the following figure.

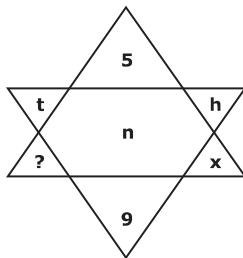

- A. y
- B. e
- C. w
- D. d

10. The two pie-charts given below show the data of total students and only girls registered in different streams in a university. If the total number of students registered in the

university is 5000, and the total number of the registered girls is 1500; then the ratio of boys enrolled in Arts to the girls enrolled in Management is

Percentage of students enrolled in different streams in a University

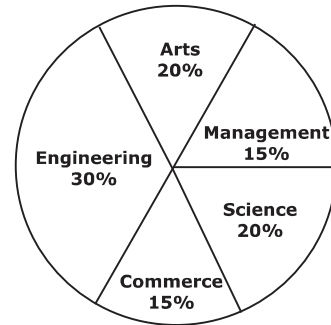

Percentage of girls enrolled in different streams

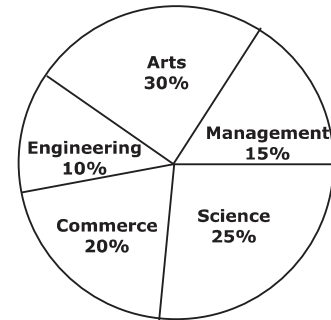

- A. 11: 9
- B. 9: 22
- C. 2: 1
- D. 22: 9

MECHANICAL ENGINEERING

- For an air-standard Diesel cycle,
 - heat addition is at constant pressure and heat rejection is at constant pressure
 - heat addition is at constant volume and heat rejection is at constant pressure
 - heat addition is at constant volume and heat rejection is at constant volume
 - heat addition is at constant pressure and heat rejection is at constant volume
- A machine member is subjected to fluctuating stress $\sigma = \sigma_0 \cos(8\pi t)$. The endurance limit of the material is 350 MPa. If the factor of safety used in the design is 3.5 then the maximum allowable value of σ_0 is _____ MPa (round off to 2 decimal places).
- The values of enthalpies at the stator inlet and rotor outlet of a hydraulic turbo machine stage are h_1 and h_3 respectively. The enthalpy at the stator outlet (or, rotor inlet) is h_2 . The condition $(h_2 - h_1) = (h_3 - h_2)$ indicates that the degree of reaction of this stage is
 - 100%
 - 75%
 - 50%
 - zero
- A circular disk of radius r is confirmed to roll without slipping at P and Q as shown in the figure.

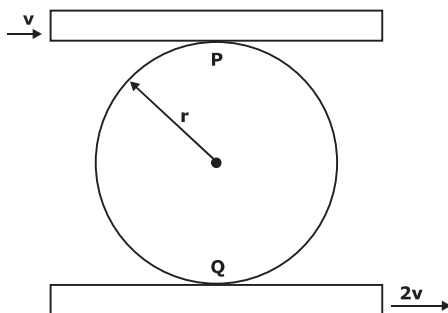

If the plates have velocities as shown, the magnitude of the angular velocity of the disk is

- $\frac{v}{r}$
- $\frac{v}{2r}$
- $\frac{3v}{2r}$
- $\frac{2v}{3r}$

- Which one of the following statements about a phase diagram is INCORRECT?
 - It gives information on transformation rates
 - Solid solubility limits are depicted by it
 - Relative amount of different phases can be found under given equilibrium conditions
 - It indicates the temperature at which different phases start to melt
- Consider the following network of activities, with each activity named A-L, illustrated in the nodes of the network.

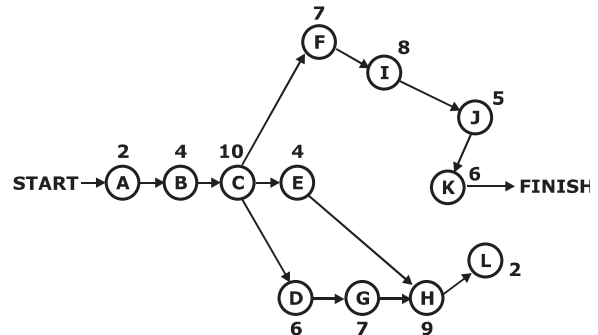

The number of hours required for each activity is shown alongside the nodes. The slack on the activity L, is _____ hours.

- In a furnace, the inner and outer sides of the brick wall ($k_1 = 2.5 \text{ W/m.K}$) are maintained at 1100°C and 700°C , respectively as shown in figure.

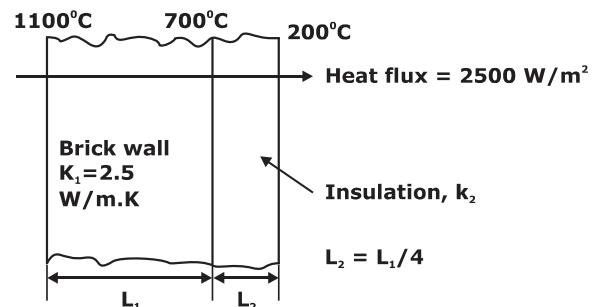

The brick wall is covered by an insulating material of thermal conductivity k_2 . The thickness of the insulation is $1/4^{\text{th}}$ of the thickness of the brick wall. The outer surface of the insulation is at 200°C . The heat flux through the composite walls is 2500 W/m^2 .

The value of k_2 is _____ W/m.K (round off to one decimal place).

8. A closed vessel contains pure water, in thermal equilibrium with its vapour at 25°C (Stage #1), as shown.

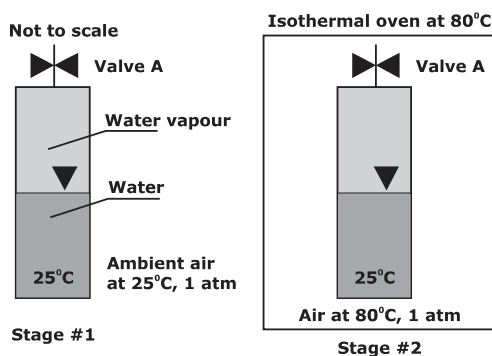

The vessel in this stage is then kept inside an isothermal oven which is having an atmosphere of hot air maintained at 80°C . The vessel exchanges heat with the oven atmosphere and attains a new thermal equilibrium (Stage #2). If the Valve A is now opened inside the oven, what will happen immediately after opening the valve?

- A. Hot air will go inside the vessel through Valve A
 B. Water vapour inside the vessel will come out of the Valve A
 C. All the vapour inside the vessel will immediately condense
 D. Nothing will happen – the vessel will continue to remain in equilibrium
9. Let $I = \int_{x=0}^1 \int_{y=0}^{x^2} xy^2 dy dx$. Then, I may also be expressed as

- A. $\int_{y=0}^1 \int_{x=0}^{\sqrt{y}} yx^2 dx dy$
 B. $\int_{y=0}^1 \int_{x=0}^{\sqrt{y}} xy^2 dx dy$
 C. $\int_{y=0}^1 \int_{x=\sqrt{y}}^1 xy^2 dx dy$
 D. $\int_{y=0}^1 \int_{x=\sqrt{y}}^1 yx^2 dx dy$

10. The number of qualitatively distinct kinematic inversions possible for a Grashof chain with four revolute pairs is
- A. 2
 B. 1
 C. 3
 D. 4
11. In Materials Requirement Planning, if the inventory holding cost is very high and the setup cost is zero, which one of the following lot sizing approaches should be used?
- A. Economic Order Quantity
 B. Lot-for-Lot
 C. Fixed Period Quantity, for 2 periods
 D. Base Stock Level
12. The sum of two normally distributed random variables X and Y is
- A. normally distributed, only if X and Y have the same mean
 B. normally distributed, only if X and Y are independent
 C. always normally distributed
 D. normally distributed, only if X and Y have the same standard deviation
13. Which of the following conditions is used to determine the stable equilibrium of all partially submerged floating bodies?
- A. Metacentre must be at a higher level than the centre of gravity
 B. Centre of buoyancy must be above the centre of gravity

- C. Metacentre must be at a lower level than the centre of gravity
- D. Centre of buoyancy must be below the centre of gravity

- 14.** The process, that uses a tapered horn to amplify and focus the mechanical energy for machining of glass, is
- A. electrical discharge machining
 - B. ultrasonic machining
 - C. abrasive jet machining
 - D. electrochemical machining
- 15.** A bolt head has to be made at the end of a rod of diameter $d = 12$ mm by localized forging (upsetting) operation. The length of the unsupported portion of the rod is 40 mm. To avoid buckling of the rod, a closed forging operation has to be performed with a maximum die diameter of _____ mm.
- 16.** Two plates, each of 6 mm thickness, are to be butt-welded. Consider the following processes and select the correct sequence in increasing order of size of the heat affected zone.
1. Arc welding
 2. MIG welding
 3. Laser beam welding
 4. Submerged arc welding
- A. 4-3-2-1 B. 3-2-4-1
 - C. 1-4-2-3 D. 3-4-2-1
- 17.** An attempt is made to pull a roller of weight W over a curb (step) by applying a horizontal force F as shown in the figure.

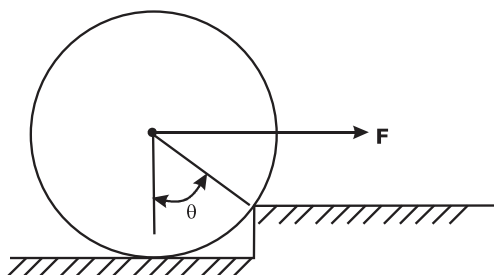

The coefficient of static friction between the roller and the ground (including the edge of the step) is μ . Identify the correct free body diagram (FBD) of the roller when the roller is just about to climb over the step.

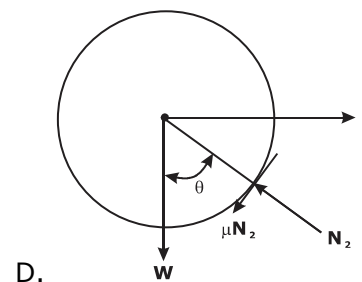
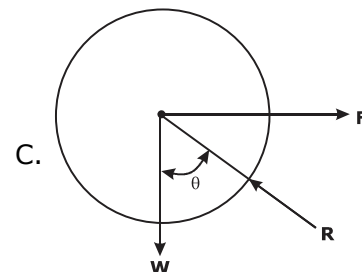
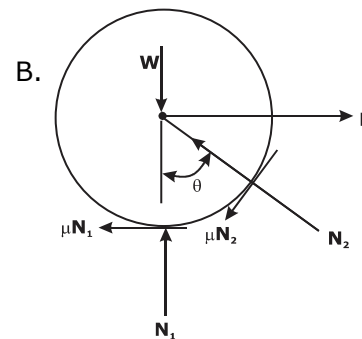
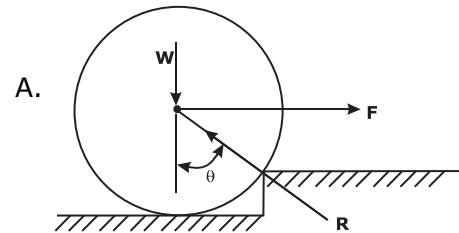

- 18.** A matrix P is decomposed into its symmetric part S and skew symmetric part V . If

$$S = \begin{pmatrix} -4 & 4 & 2 \\ 4 & 3 & 7/2 \\ 2 & 7/2 & 2 \end{pmatrix}, V = \begin{pmatrix} 0 & -2 & 3 \\ 2 & 0 & 7/2 \\ -3 & -7/2 & 0 \end{pmatrix},$$

then matrix P is

A. $\begin{pmatrix} -4 & 6 & -1 \\ 2 & 3 & 0 \\ 5 & 7 & 2 \end{pmatrix}$

B. $\begin{pmatrix} -4 & 2 & 5 \\ 6 & 3 & 7 \\ -1 & 0 & 2 \end{pmatrix}$

C. $\begin{pmatrix} -2 & 9/2 & -1 \\ -1 & 81/4 & 11 \\ -2 & 45/2 & 73/4 \end{pmatrix}$

D. $\begin{pmatrix} 4 & -6 & 1 \\ -2 & -3 & 0 \\ -5 & -7 & -2 \end{pmatrix}$

19. A beam of negligible mass is hinged at support P and has a roller support Q as shown in the figure.

20. The solution of $\frac{d^2y}{dt^2} - y = 1$, which additionally satisfies

$y|_{t=0} = \frac{dy}{dt}|_{t=0} = 0$ in the Laplace s-domain is

A. $\frac{1}{s-1}$

B. $\frac{1}{s(s-1)}$

C. $\frac{1}{s(s+1)}$

D. $\frac{1}{s(s+1)(s-1)}$

21. If a reversed Carnot cycle operates between the temperature limits of 27°C and -3°C, then the ratio of the COP of a refrigerator to that of a heat pump (COP of refrigerator/COP of heat pump) based on the cycle is _____ (round off to 2 decimal places).

22. The figure below shows a symbolic representation of the surface texture in a perpendicular lay orientation with indicative values (I through VI) marking the various specifications whose definitions are listed below.

P: Maximum Waviness Height (mm); Q: Maximum Roughness Height (mm); R: Minimum Roughness Height (mm); S: Maximum Waviness Width (mm); T: Maximum Roughness Width (mm); U: Roughness Width Cutoff (mm).

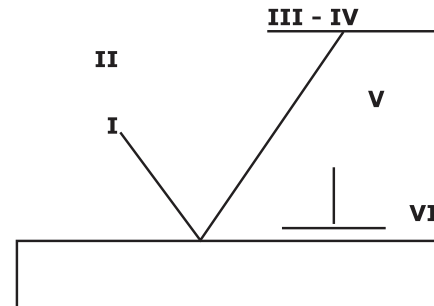

The correct match between the specifications and the symbols (I to VI) is

- A. I-Q, II-U, III-R, IV-T, V-S, VI-P
- B. I-R, II-Q, III-P, IV-S, V-U, VI-T
- C. I-R, II-P, III-U, IV-S, V-T, VI-Q
- D. I-U, II-S, III-Q, IV-T, V-R, VI-P

23. The equation of motion of a spring-mass-damper system is given by

$$\frac{d^2x}{dt^2} + 3\frac{dx}{dt} + 9x = 10\sin(5t).$$

The damping factor for the system is

- A. 0.5
- B. 2
- C. 0.25
- D. 3

24. In the space above the mercury column in a barometer tube, the gauge pressure of the vapour is

- A. zero
- B. positive, but less than one atmosphere
- C. positive, but more than one atmosphere
- D. negative

25. Let I be a 100-dimensional identity matrix and E be the set of its distinct (no value appears more than once in E) real eigenvalues. The number of elements in E is _____.

- 26.** There are two identical shaping machines S_1 and S_2 . In machine S_2 , the width of the workpiece is increased by 10% and the feed is decreased by 10%, with respect to that of S_1 . If all other conditions remain the same then the ratio of total time per pass in S_1 and S_2 will be _____ (round off to one decimal place).
- 27.** Water (density 1000 kg/m^3) flows through an inclined pipe of uniform diameter. The velocity, pressure and elevation at section A are $V_A = 3.2 \text{ m/s}$, $p_A = 186 \text{ kPa}$ and $z_A = 24.5 \text{ m}$, respectively, and those at section B are $V_B = 3.2 \text{ m/s}$, $p_B = 260 \text{ kPa}$ and $z_B = 9.1 \text{ m}$, respectively. If acceleration due to gravity is 10 m/s^2 then the head lost due to friction is _____ m (round off to one decimal place).
- 28.** A thin-walled cylinder of radius r and thickness t is open at both ends, and fits snugly between two rigid walls under ambient conditions, as shown in the figure.

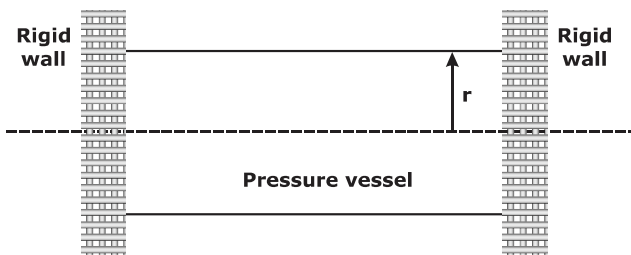

The material of the cylinder has Young's modulus E , Poisson's ratio ν , and coefficient of thermal expansion α . What is the minimum rise in temperature ΔT of the cylinder (assume uniform cylinder temperature with no buckling of the cylinder) required to prevent gas leakage if the cylinder has to store the gas at an internal pressure of p above the atmosphere?

- A. $\Delta T = \left(\nu - \frac{1}{4} \right) \frac{pr}{\alpha t E}$
- B. $\Delta T = \frac{3 \nu pr}{2 \alpha t E}$

- C. $\Delta T = \left(\nu + \frac{1}{2} \right) \frac{pr}{\alpha t E}$
- D. $\Delta T = \frac{\nu pr}{\alpha t E}$

- 29.** For the integral $\int_0^{\pi/2} (8 + 4 \cos x) dx$, the absolute percentage error in numerical evaluation with the Trapezoidal rule, using only the end points, is _____ (round off to one decimal place).
- 30.** A helical spring has spring constant k . If the wire diameter, spring diameter and the number of coils are all doubled then the spring constant of the new spring becomes
- A. $8k$ B. k
- C. $k/2$ D. $16k$
- 31.** The sun (S) and the planet (P) of an epicyclic gear train shown in the figure have identical number of teeth.

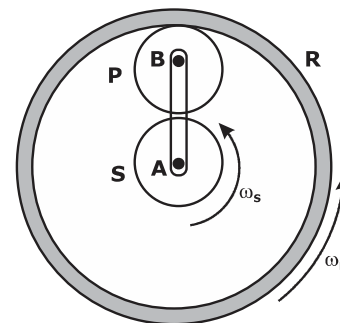

If the sun (S) and the outer ring (R) gears are rotated in the same direction with angular speed ω_s and ω_R , respectively, then angular speed of the arm AB is

- A. $\frac{1}{4} \omega_R + \frac{3}{4} \omega_s$ B. $\frac{3}{4} \omega_R - \frac{1}{4} \omega_s$
- C. $\frac{1}{2} \omega_R - \frac{1}{2} \omega_s$ D. $\frac{3}{4} \omega_R + \frac{1}{4} \omega_s$
- 32.** Moist air at 105 kPa , 30°C and 80% relative humidity flows over a cooling coil in an insulated air-conditioning duct. Saturated air exits the duct at 100 kPa and 15°C . The

saturation pressures of water at 30°C and 15°C are 4.24 kPa and 1.7 kPa respectively. Molecular weight of water is 18 g/mol and that of air is 28.94 g/mol. The mass of water condensing out from the duct is _____ g/kg of dry air (round off to the nearest integer).

- 33.** Two rollers of diameters D_1 (in mm) and D_2 (in mm) are used to measure the internal taper angle in the V-groove of a machined component. The heights H_1 (in mm) and H_2 (in mm) are measured by using a height gauge after inserting the rollers into the same V-groove as shown in the figure.

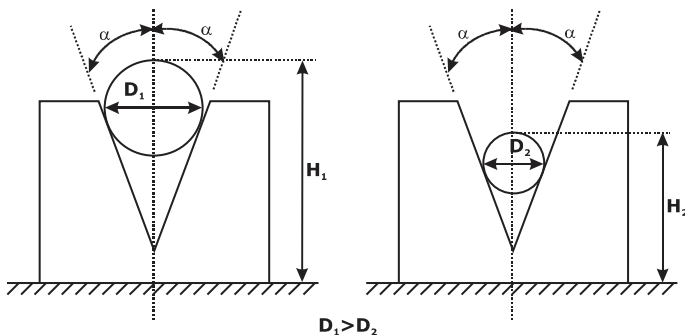

Which one of the following is the correct relationship to evaluate the angle α as shown in the figure?

- A. $\sin \alpha = \frac{(H_1 - H_2)}{(D_1 - D_2)}$
- B. $\cos \alpha = \frac{(D_1 - D_2)}{2(H_1 - H_2) - 2(D_1 - D_2)}$
- C. $\sin \alpha = \frac{(D_1 - D_2)}{2(H_1 - H_2) - (D_1 - D_2)}$
- D. $\operatorname{cosec} \alpha = \frac{(H_1 - H_2) - (D_1 - D_2)}{2(D_1 - D_2)}$

- 34.** A hollow spherical ball of radius 20 cm floats in still water, with half of its volume submerged. Taking the density of water as 1000 kg/m³, and the acceleration due to gravity as 10 m/s², the natural frequency of small oscillations of the ball, normal to the water surface is _____ radians/s (round off to 2 decimal places).

- 35.** Air is contained in a frictionless piston-cylinder arrangement as shown in the figure.

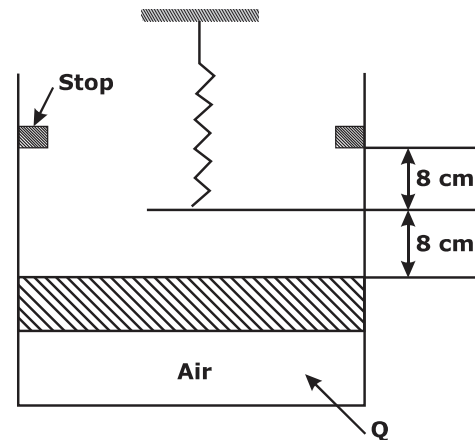

The atmospheric pressure is 100 kPa and the initial pressure of air in the cylinder is 105 kPa. The area of piston is 300 cm². Heat is now added and the piston moves slowly from its initial position until it reaches the stops. The spring constant of the linear spring is 12.5 N/mm. Considering the air inside the cylinder as the system, the work interaction is _____ J (round off to the nearest integer).

- 36.** A rigid block of mass $m_1 = 10$ kg having velocity $v_0 = 2$ m/s strikes a stationary block of mass $m_2 = 30$ kg after travelling 1 m along a frictionless horizontal surface as shown in the figure.

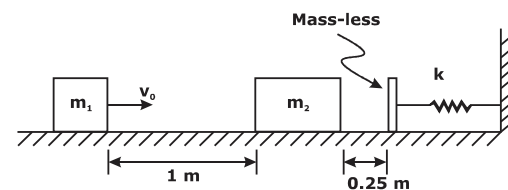

The two masses stick together and jointly move by a distance of 0.25 m further along the same frictionless surface, before they touch the mass-less buffer that is connected to the rigid vertical wall by means of a linear spring having a spring constant $k = 10^5$ N/m. The maximum deflection of the spring is _____ cm (round off to 2 decimal places).

37. Bars of 250 mm length and 25 mm diameter are to be turned on a lathe with a feed of 0.2 mm/rev. Each regrinding of the tool costs Rs. 20. The time required for each tool change is 1 min. Tool life equation is given as $VT^{0.2} = 24$ (where cutting speed V is in m/min and tool life T is in min). The optimum tool cost per piece for maximum production rate is Rs. _____ (round off to 2 decimal places).

38. In a steam power plant, superheated steam at 10 MPa and 500°C, is expanded isentropically in a turbine until it becomes a saturated vapour. It is then reheated at constant pressure to 500°C. The steam is next expanded isentropically in another turbine until it reaches the condenser pressure of 20 kPa. Relevant properties of steam are given in the following two tables. The work done by both the turbines together is _____ kJ/kg (round off to the nearest integer).

Superheated Steam Table:

Pressure, p (MPa)	Temperature, T (°C)	Enthalpy, h (kJ/kg)	Entropy, s (kJ/kg.K)
10	500	3373.6	6.5965
1	500	3478.4	7.7621

Saturated Steam Table:

Pressure, p	Sat. Temp. T _{sat} (°C)	Enthalpy, h (kJ/kg)		Entropy, s (kJ/kg.K)	
		h _f	h _g	s _f	s _g
1 MPa	179.91	762.9	2778.1	2.1386	6.5965
20 kPa	60.06	251.38	2609.7	0.8319	7.9085

39. A cylindrical bar with 200 mm diameter is being turned with a tool having geometry 0° - 9° - 7° - 8° - 15° - 30° - 0.05 inch (Coordinate system,

ASA) resulting in a cutting force F_{c1} . If the tool geometry is changed to 0° - 9° - 7° - 8° - 15° - 0° - 0.05 inch (Coordinate system, ASA) and all other parameters remain unchanged, the cutting force changes to F_{c2} . Specific cutting energy (in J/mm³) is $U_c = U_0 (t_1)^{-0.4}$, where U_0 is the specific energy coefficient, and t_1 is the uncut thickness in mm. The value of percentage change in cutting force F_{c2} , i.e.

$$\left(\frac{F_{c2} - F_{c1}}{F_{c1}} \right) \times 100, \text{ is } \underline{\hspace{2cm}} \text{ (round off to one decimal place).}$$

40. A fair coin is tossed 20 times. The probability that 'head' will appear exactly 4 times in the first ten tosses, and 'tail' will appear exactly 4 times in the next ten tosses is _____ (round off to 3 decimal places).

41. The forecast for the monthly demand of a product is given in the table below.

Month	Forecast	Actual Sales
1	32.00	30.00
2	31.80	32.00
3	31.82	30.00

The forecast is made by using the exponential smoothing method. The exponential smoothing coefficient used in forecasting the demand is

- A. 1.00
- B. 0.10
- C. 0.50
- D. 0.40

42. A steel spur pinion has a module (m) of 1.25 mm, 20 teeth and 20° pressure angle. The pinion rotates at 1200 rpm and transmits power to a 60 teeth gear. The face width (F) is 50 mm, Lewis form factor $Y = 0.322$ and a dynamic factor $K_v = 1.26$. The bending stress (σ) induced in a tooth can be calculated by using the Lewis formula given below.

If the maximum bending stress experienced by the pinion is 400 MPa, the power transmitted is _____ kW (round off to one decimal place).

Lewis formula: $\sigma = \frac{k_v W^t}{FmY}$, where W^t is the tangential load acting on the pinion.

- 43.** A mould cavity of 1200 cm³ volume has to be filled through a sprue of 10 cm length feeding a horizontal runner. Cross-sectional area at the base of the sprue is 2 cm². Consider acceleration due to gravity as 9.81 m/s². Neglecting frictional losses due to molten metal flow, the time taken to fill the mould cavity is _____ seconds (round off to 2 decimal places).
- 44.** A cantilever of length l , and flexural rigidity EI , stiffened by a spring of stiffness k , is loaded by a transverse force P , as shown.

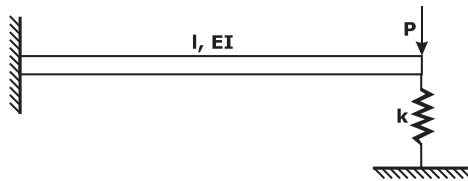

The transverse deflection under the load is

- A. $\frac{Pl^3}{3EI} \left[\frac{3EI}{3EI + 2kl^3} \right]$ B. $\frac{Pl^3}{3EI} \left[\frac{3EI - kl^3}{3EI} \right]$
 C. $\frac{Pl^3}{3EI} \left[\frac{3EI}{3EI + kl^3} \right]$ D. $\frac{Pl^3}{3EI} \left[\frac{6EI - kl^3}{6EI} \right]$

- 45.** The turning moment diagram of a flywheel fitted to a fictitious engine is shown in the figure.

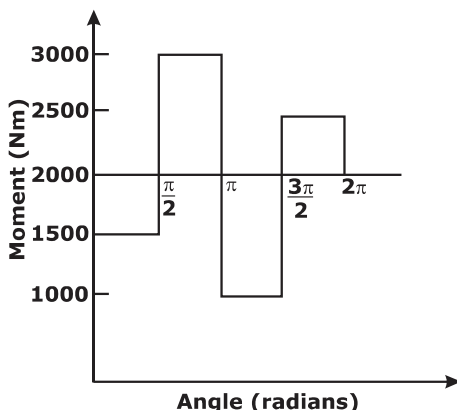

The mean turning moment is 2000 Nm. The average engine speed is 1000 rpm. For fluctuation in the speed to be within $\pm 2\%$ of the average speed, the mass moment of inertia of the flywheel is _____ kg.m².

- 46.** For a single item inventory system, the demand is continuous, which is 10000 per year. The replenishment is instantaneous and backorders (S units) per cycle are allowed as shown in the figure.

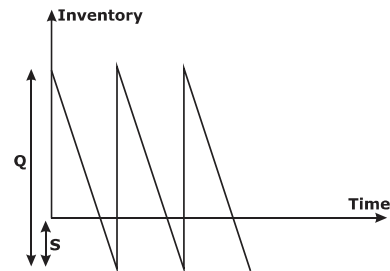

As soon as the quantity (Q units) ordered from the supplier is received, the backordered quantity is issued to the customers. The ordering cost is Rs. 300 per order. The carrying cost is Rs. 4 per unit per year. The cost of backordering is Rs. 25 per unit per year. Based on the total cost minimization criteria, the maximum inventory reached in the system is _____ (round off to nearest integer).

- 47.** Uniaxial compression test data for a solid metal bar of length 1 m is shown in the figure.

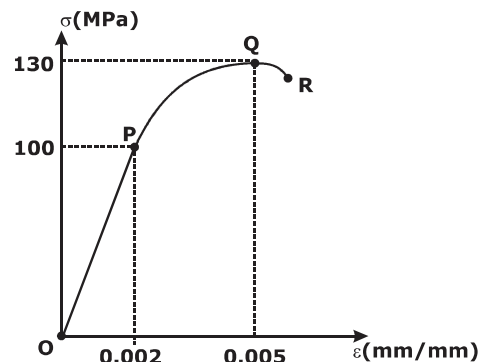

The bar material has a linear elastic response from O to P followed by a nonlinear response. The point P represents the yield point of the

material. The rod is pinned at both the ends. The minimum diameter of the bar so that it does not buckle under axial loading before reaching the yield point is _____ mm (round off to one decimal place).

48. Keeping all other parameters identical, the Compression Ratio (CR) of an air standard diesel cycle is increased from 15 to 21. Take ratio of specific heats = 1.3 and cut-off ratio of the cycle $r_c = 2$.

The difference between the new and the old efficiency values, in percentage, $(\eta_{\text{new}}|_{\text{CR}=21}) - (\eta_{\text{old}}|_{\text{CR}=15}) =$ _____ % (round off to one decimal place).

49. The function $f(z)$ of complex variable $z = x + iy$, where $i = \sqrt{-1}$, is given as $f(z) = (x^3 - 3xy^2) + i v(x, y)$. For this function to be analytic, $v(x, y)$ should be
- $(x^3 - 3x^2y) + \text{constant}$
 - $(3x^2y^2 - y^3) + \text{constant}$
 - $(3x^2y - y^3) + \text{constant}$
 - $(3xy^2 - y^3) + \text{constant}$

50. Water flows through a tube of 3 cm internal diameter and length 20 m. The outside surface of the tube is heated electrically so that it is subjected to uniform heat flux circumferentially and axially. The mean inlet and exit temperatures of the water are 10°C and 70°C, respectively. The mass flow rate of the water is 720 kg/h. Disregard the thermal resistance of the tube wall. The internal heat transfer coefficient is 1697 W/m²·K. Take specific heat C_p of water as 4.179 kJ/kg·K. The inner surface temperature at the exit section of the tube is _____ °C (round off to one decimal place).

51. One kg of air in a closed system undergoes an irreversible process from an initial state of $p_1 = 1$ bar (absolute) and $T_1 = 27^\circ\text{C}$, to a final state of $p_2 = 3$ bar (absolute) and $T_2 = 127^\circ\text{C}$. If the gas constant of air is 287 J/kg·K and the ratio of the specific heats $\gamma = 1.4$, then the change in the specific entropy (in J/kg.K) of the air in the process is

- 26.3
- 28.4
- indeterminate, as the process is irreversible
- 172.0

52. Consider a flow through a nozzle, as shown in the figure below

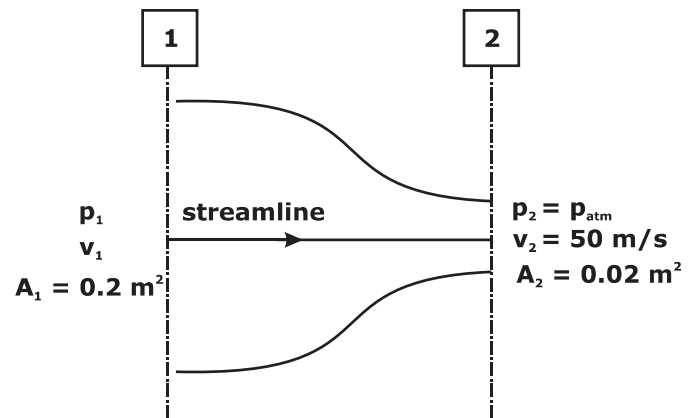

The air flow is steady, incompressible and inviscid. The density of air is 1.23 kg/m³. The pressure difference, $(p_1 - p_{\text{atm}})$ is _____ kPa (round off to 2 decimal places).

53. The spectral distribution of radiation from a black body at $T_1 = 3000$ K has a maximum at wavelength λ_{max} . The body cools down to a temperature T_2 . If the wavelength corresponding to the maximum of the spectral distribution at T_2 is 1.2 times of the original wavelength λ_{max} , then the temperature T_2 is _____ K (round off to the nearest integer).

54. A point 'P' on a CNC controlled XY-stage is moved to another point 'Q' using the coordinate system shown in the figure below and rapid positioning command (G00).

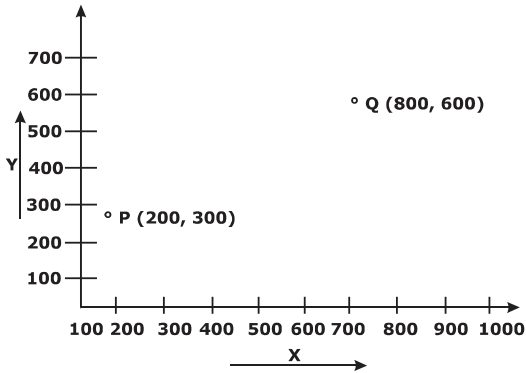

A pair of stepping motors with maximum speed of 800 rpm, controlling both the X and Y motion of the stage, are directly coupled to a pair of lead screws, each with a uniform pitch of 0.5 mm. The time needed to position the point 'P' to the point 'Q' is _____ minutes (round off to 2 decimal places).

55. The directional derivative of $f(x, y, z) = xyz$ at point $(-1, 1, 3)$ in the direction of vector $\hat{i} - 2\hat{j} + 2\hat{k}$ is

- A. $\frac{7}{3}$
- B. 7
- C. $3\hat{i} - 3\hat{j} - \hat{k}$
- D. $-\frac{7}{3}$

Benefits of Online Classroom Program

1. GATE Learning Tablet

- › Access high-quality classes at your convenience, anywhere and anytime with the tablet

2. Live Classroom Sessions

- › Get Access to Live Classes By India's Leading GATE Faculty

3. Previous Year Question Books

- › 20+ Years PYQs with Solutions

4. Workbooks

- › Access to 3000+ Practice Questions with solutions

5. Regular Quizzes

- › Sample Quizzes for daily practice and regular tests along with live class

6. Doubt Resolution

- › Complete Doubt Resolution within 24 hours by Subject Experts

Additional Offerings

- › **Test Series** - Mock Tests based on GATE Exam pattern
- › **Preparation Guidance** - Get a competitive advantage from our Experts
- › **Subject wise formula Notes** - Comprehensive short notes for Revision
- › **Report Card** - Regular performance analysis along with Live Class