

UPPSC 2019 Paper 2

1. A large tank near Mahoba, temples at Ajaygarh and Mahoba and city of Rajavasini were built by a Chandella King

- A. Nannuk
- B. Vakpati
- C. Rahil
- D. Jayashakti

2. Which of the following Rights a cultivator enjoyed on his own land during the Mughal period?

- A. Right to mortgage only
- B. Right to sell and gift
- C. Right to mortgage and gift
- D. All the above rights

3. Match List-I with List-II and select the correct. answer using the code given below.

	List-I (Tribes)		List-II (States)
a.	Tharus	1.	Madhya Pradesh
b.	Todas	2.	Jharkhand
c.	Santhal	3.	Uttarakhand
d.	Gond	4.	Tamil Nadu

Code:

- | | | | | |
|----|---|---|---|---|
| | a | b | c | d |
| A. | 1 | 3 | 4 | 2 |
| B. | 4 | 2 | 1 | 3 |
| C. | 2 | 1 | 3 | 4 |
| D. | 3 | 4 | 2 | 1 |

4. Match List-I with List-II and choose the correct answer using the code given below:

List-I (Text)

- a. Kiratarjuniyam
- b. Dashakumar Charitam
- c. Buddha Charitam

d. Vikramorvashiyam

List-II (Writer)

1. Dandi
2. Kalidas
3. Bharavi
4. Ashvaghosha

Code:

	a	b	c	d
A.	3	4	1	2
B.	3	1	4	2
C.	2	3	1	4
D.	1	3	2	4

5. Match List-I with List II and choose the correct answer using the code given below:

List-I (Text)

- a. Nokrek
- b. Agasthyamalai
- c. Nandadevi
- d. Dehang Debang

List-II (Writer)

1. Uttarakhand
2. Arunachal Pradesh
3. Kerala
4. Meghalaya

Codes:

	a	b	c	d
A.	4	3	1	2
B.	4	3	2	1
C.	3	4	1	2
D.	2	3	4	1

6. States get share of the revenue from

- A. Income Tax
- B. Customs Revenue
- C. Excise Tax
- D. Surcharge on income Tax

7. Which Article of the Indian Constitution empowers Parliament to make law for implementing international agreements?

- A. Article 249
- B. Article 250
- C. Article 252 .
- D. Article 253

8. Who appoints the acting Chief Justice of India?

- A. Chief Justice of India
- B. Chief Justice of India with previous consent of the President
- C. President of India
- D. President in consultation with the Chief Justice of India

9. The rotation intensity of Maize-Mustard-Mung crop is

- A. 100 %
- B. 200 %
- C. 300 %
- D. 400 %

10 Which of the following is NOT a Kharif crop?

- A. Soyabean
- B. Lentil
- C. Cotton
- D. Pigeon pea

11. 'Five Star Village Scheme' started by Government of India in September 2020 relates to which one of the following?

- A. Electricity Supply

- B. Postal Service Schemes.
- C. Health Services
- D. Primary Education

12. Who won the US Open 2020, Mens Tennis Singles Title on 14th September, 2020 ?

- A. Alex Zverev
- B. Dominic Thiem
- C. D. Medvedev
- D. P.C. Busta

13. Which of the following pairs is NOT correctly matched?

	Ancient name of the cities	Modern name of the cities
A.	Esipattan	Saranath
B.	Dashapur	Mandsor
C.	Banvasi	Talkad
D.	Mahoday	Kannauj

14. The early farming site located on the bank of lake is

- A. Mehargarh
- B. Lahuradeva
- C. Chirand
- D. T. Narsipur

15. Author of the 'Dastane Mazahib' which discusses about the Din-i-Ilahi of Akbar, was

- A. Mohammad Rabbani
- B. Mohsin Faani
- C. Badauni
- D. Afif

16. Who was appointed the Minister of 'Ministry of Rehabilitation' set up on 06 September, 1947 ?

- A. S.P. Mukerji
- B. Sardar Vallabhbhai Patel
- C. J.L. Nehru
- D. K.C. Niyogi

17. Match List-I with List-II and select the correct answer using the code given below:

	List-I (States)		List-II (Highest Peaks)
(a)	Tamil Nadu	1.	Dhoopgarh
(b)	Rajasthan	2.	Saramati
(c)	Nagaland	3.	Guru Shikhar
(d)	Madhya Pradesh	4.	Doda Betta

Code:

- | | a | b | c | d |
|----|---|---|---|---|
| A. | 3 | 4 | 1 | 2 |
| B. | 1 | 2 | 4 | 3 |
| C. | 4 | 3 | 2 | 1 |
| D. | 2 | 1 | 3 | 4 |

18. Leopold Matrix is associated with

- A. Weather Forecasting
- B. Disaster Management
- C. Environmental Impact Assessment Method
- D. Environment Law

19. The Joint Sitting of the Indian Parliament for transacting a legislative business is presided over by

- A. The President of India
- B. The senior most Member of Parliament
- C. The Chairman of the Rajya Sabha
- D. The Speaker of the Lok Sabha

20. The term 'Office of Profit' has been defined by the

- A. Constitution
- B. Parliament
- C. Supreme Court
- D. Union Council of Ministers

21. While deciding any question relating to the disqualification of a Member of Parliament, the President shall obtain the opinion of

- A. Election Commission
- B. Chief Justice of India
- C. Attorney General
- D. Speaker of the Lok Sabha

22. Soyabean seed contains

- A. 20 % protein and 40 % oil
- B. 40 % protein and 10 % oil
- C. 40 % protein and 20 % oil
- D. 20 % protein and 20 % oil

23. As per the results of 'Swachh Sarvekshan 2020', announced by Ministry of Housing and Urban Affairs on 20th August 2020, which is the Cleanest City in Uttar Pradesh?

- A. Agra
- B. Ghaziabad
- C. Lucknow
- D. Prayagraj

24. How many teachers from Uttar Pradesh were selected for 'National Award' on Teachers day 5th Sept, 2020 ?

- A. Six
- B. Five
- C. Four
- D. Three

25. 'Poshan Maah' was celebrated by Government of India in the year 2020 , in which of the following months?

- A. September
- B. August
- C. July
- D. June

26. A tank containing air is stirred by a paddle wheel. The work input to the paddle wheel is 6000 kJ. The heat transferred to the surroundings from the tank is 3000 kJ. The external work done by the system is

- A. Zero
- B. 3000 kJ
- C. 6000 kJ
- D. 9000 kJ

27. If specific heat ratio for a gas is γ , the change in internal energy of a mass of gas at constant pressure P. when volume changes from V to 2V is

- A. $\frac{PV}{\gamma - 1}$
- B. $\frac{R}{\gamma - 1}$
- C. PV
- D. $\frac{\gamma PV}{\gamma - 1}$

28. When the depth of immersion of a plane surface is increased the centre of pressure will

- A. come closer to centroid
- B. move farther away from the centroid
- C. will remain unchanged
- D. depends on the specific weight of the liquid

29. If a pure substance is below the triple point temperature, the solid on being heated will only

- A. temperature remain constant
- B. liquify
- C. vapourize or sublimate
- D. have its temperature increased

30. Velocity at a point in a pipe flow may be measured by installing

- A. a Pitot probe at that point
- B. a wall trap
- C. a stagnation pressure probe at that point.
- D. a Prandtl probe at that point

31. A 2kW electric resistance heater submerged in 5 kg water is turned on and kept on for 10 minutes. During the process, 300 kJ of heat is lost from the water, the temperature rise of water is

- A. 0.4°C
- B. 43.1°C
- C. 57.4°C
- D. 71.8°C

32. If the stream function is given by $\psi = 3x - y$, then the velocity at point (2,3) will be

- A. 7.21 unit
- B. 10.82 unit
- C. 18 unit
- D. 54 unit

33. The pressure and temperature of mixture of 4 kg O₂ and 6 kg N₂ are 4 bar and 27°C. What will be the value of molecular weight of mixture?

- A. 40.67
- B. 39.87
- C. 29.47
- D. None of the above

34. The shear stress between two fixed parallel plates with a laminar flow between them.

- A. a constant across the gap
- B. varies parabolically as the distance from the mid plane
- C. Varies inversely as the distance for the mid plane
- D. Varied directly as the distance from the mid plane

35. A vapour while condensing at 420°C , transfers heat to water evaporating at 250°C . If ambient is. at 35°C , what fraction of available energy is lost in the process?

- A. 0.18
- B. 0.22
- C. 0.26°C
- D. 0.30

36. Given power 'P' of a pump, the head 'H', the discharge 'Q' and specific weight 'w' of the liquid, dimensional analysis would lead to the result that 'P' is proportional to

- A. $H^{1/2} Q^2 w$
- B. $H^{1/2} Q w$
- C. $H Q^{1/2} w$
- D. $H Q w$

37. In which of the following situations, the entropy change is negative?

- A. Air expands isothermally from 6 bar to 3 bar
- B. Air is compressed to half of its volume at constant pressure
- C. Air is supplied with heat at constant volume till its pressure is doubled
- D. Air expands adiabatically from 6 bar to 3 bar

38. A dimensionless group formed with the variable ρ , ω , μ and D is

- A. $\rho \omega \mu/D^2$
- B. $\rho \omega D^2/\mu$
- C. $\mu D^2 \rho \omega$
- D. $\rho \omega \mu D$

39 Biot number signifies

- (a) the ratio of heat conducted to heat convected

- (b) the ratio of heat convected to heat conducted
- (c) the ratio of external convective resistance to internal conductive resistance
- (d) the ratio of internal conductive resistance to external convective resistance

40. The centre of pressure of a vertical rectangular plate with height of h m from its base is at

- A. $\frac{h}{2}$ from base
- B. $\frac{h}{3}$ from base
- C. $\frac{2h}{3}$ from base
- D. $\frac{3h}{4}$ from base

42. Turbulence in a flow implies

- A. random component of velocity superimposed on the mean flow
- B. unsteadiness of flow
- C. non-uniformity of flow
- D. unsteadiness and non-uniformity of flow

43. In certain heat exchanger, both the fluids have identical mass flow rate-specific heat product. The hot fluid enters at 76°C and leaves at 47°C and the cold fluid entering at 28°C leaves at 57°C . The effectiveness of the heat exchanger is

- A. 0.16
- B. 0.60
- C. 0.72
- D. 1.00

44. An object weights 50 N in water. Its volume is 15.3 liter. Its weight when fully immersed in an oil by specific gravity 0.8 will be

- A. 40 N
- B. 62.5 N
- C. 80 N
- D. 65 N

45. Uniform heat generation takes place in a symmetric slab so that heat flows towards both side in contact with fluid. The zero gradient boundary condition $\frac{\partial T}{\partial x} = 0$, occurs at

- A. centre line of slab
- B. left wall of slab
- C. right wall of slab
- D. nowhere in slab

46. Flow in a pipe takes place from

- A. higher level to lower level
- B. higher velocity to lower velocity
- C. higher pressure to lower pressure
- D. higher energy to lower energy

47. The shape factor of a hemispherical body placed on a flat surface with respect to itself is

- A. zero
- B. 0.25
- C. 0.5
- D. 1.0

48. A potential function

- A. is constant along a streamline,
- B. is defined, if streamline function is available for the flow
- C. describe the flow, if it is rotational
- D. describe the flow, if it is irrotational

49. The average diameter of water drops from the water spray in a cooling tower is 1.5 mm. The relative velocity between the water drops and the air current may be taken as 0.9 m/s. The air and water temperatures are 15°C and 80°C respectively. Compute the connective coefficient of heat transfer.

- A. 165 W/m²K
- B. 80 W/m²K
- C. 100 W/m²K

D. 14.5 W/m²K

50. Shear strain rate in a fluid is given by

A. $\frac{1}{2} \left(\frac{\partial u}{\partial x} + \frac{\partial v}{\partial y} \right)$

B. $\frac{1}{2} \left(\frac{\partial v}{\partial x} + \frac{\partial u}{\partial y} \right)$

C. $\left(\frac{\partial u}{\partial x} + \frac{\partial v}{\partial y} \right)$

D. $\left(\frac{\partial v}{\partial x} + \frac{\partial u}{\partial y} \right)$

51. In a counter flow heat exchanger, hot fluid enters at 60°C and cold fluid leaves at 30°C. Mass flow rate of the hot fluid is 1 kg/s and that of the cold fluid is 2 kg/s. Specific heat of the hot fluid is 10 kJ/kgK and that of cold fluid is 5 kJ/kgK. The Log Mean Temperature Difference (LMTD) for the] heat exchanger in °C is

A. 15

B. 30

C. 35

D. 45

52. An object weighing 100 N in air was found to weight 75 N when fully submerged in water. The relative density of the object is

A. 4.0

B. 4.5

C. 2.5

D. 1.125

53. For a flow over a flat plate, the hydrodynamic boundary layer thickness is 0.5 mm. The fluid viscosity is 25×10^{-6} Pa.s, specific heat is 2.0 kJ/kgK and thermal conductivity is 0.05 W/m-K. the thermal boundary layer thickness would be

A. 0.1 mm

B. 0.5 mm

C. 1 mm

D. 1.5 mm

54. A vacuum gauge fixed on a steam condenser reads 80 kPa. The barometer indicates 1.013 bar. The absolute pressure in terms of mercury head

- A. 160 mm of Hg
- B. 190 mm of Hg
- C. 380 mm of Hg
- D. 760 mm of Hg

55. A wall thickness of 0.6 m has nominal area 1.5 m^2 and is made up of material of thermal conductivity 0.4 W/mK . The temperature on the two sides are 800°C and 100°C . What is the thermal resistance of the wall?

- A. 1 W/K
- B. 1.8 W/K
- C. 1 K/W
- D. 1.8 K/W

56. If the surface tension of water-air interface is 0.073 N/m , the gauge pressure inside a rain drop of 1 mm diameter will be

- A. 0.146 N/m^2
- B. 73 N/m^2
- C. 146 N/m^2
- D. 292 N/m^2

57. In a counter flow heat exchanger, the product of specific heat and mass flow rate is the same for hot and cold fluids. If NTU is equal to 0.5 , the effectiveness of the heat exchanger is

- A. 1.0
- B. 0.5
- C. 0.33
- D. 0.2

58. A piece of wood of volume V and specific gravity 0.87 floats on the surface of a liquid of specific gravity 1.31. The portion of the wood which is submerged in the liquid will be

- A. $0.335 V$
- B. $0.665 V$
- C. $0.87 V$
- D. $0.13 V$

59. The average Nusselt number in laminar natural convection from a vertical wall at 180°C with still air at 20°C is found to be 48 . If the wall temperature becomes 30°C, all other parameter remaining the same, average Nusselt number will be

- A. 8
- B. 16
- C. 24
- D. 32

60. Which one of the following is an irrotational flow?

- A. Free vortex flow
- B. Forced vortex flow
- C. Couette flow
- D. Wake flow

61. The efficiency of a pin fin with insulated tip is

- A. $\frac{\tanh mL}{mL}$
- B. $\frac{\tanh mL}{\sqrt{kA / kP}}$
- C. $\frac{mL}{\tanh mL}$
- D. $\frac{\sqrt{hA / kP}}{\tanh mL}$

62. For the same pressure the saturation temperature of ammonia is

- A. higher than saturation temperature of water
- B. lower than saturation temperature of water
- C. same as the saturation temperature of water
- D. depends on concentration of ammonia in water

63. In case of turbulent flow through a horizontal isothermal cylinder of diameter 'D', free convection heat transfer coefficient for the cylinder will

- A. be independent of diameter
- B. vary as $D^{3/4}$

C. vary as $D^{1/4}$

D. vary as $D^{1/2}$

64. In a vapour absorption refrigerator, the temperatures of evaporator and ambient are 10°C and 30°C respectively. If the COP of the system is 2, estimate the generator temperature

A. 90°C

B. 85°C

C. 80°C

D. 75°C

65. A flat plate has thickness 5 cm, thermal conductivity 1 W/mK convective heat transfer coefficients on its two flat faces are $10\text{ W/m}^2\text{K}$ and $20\text{ W/m}^2\text{K}$. The overall heat transfer coefficient for such a plate is

A. $5\text{ W/m}^2\text{K}$

B. $6.33\text{ W/m}^2\text{K}$

C. $20\text{ W/m}^2\text{K}$

D. $30\text{ W/m}^2\text{K}$

66. In an air conditioning unit air enters the cooling coil at temperature 30°C . The coil surface temperature is -10°C . If the cooling coil bypass factor is 0.45, then the temperature at the exit will be

A. 6°C

B. 8°C

C. 10°C

D. 12°C

67. A solid copper ball of mass 500 gm when quenched in a water bath at 30°C . cools from 530°C to 430°C in 10 sec. What will be the temperature of the ball after the next 10 seconds?

A. 300°C

B. 320°C

C. 350°C

D. Cannot be determined

68. During an adiabatic saturation process of an unsaturated air, the parameters which remains constant is

- A. Dry bulb temperature
- B. Dew point temperature
- C. Thermodynamic wet bulb temperature
- D. Relative humidity.

69. Critical radius of insulation of a hollow cylinder is

- A. $\frac{2k}{h}$
- B. $\frac{k}{2h}$
- C. $\frac{k}{h}$
- D. $\sqrt{\frac{k}{h}}$

70. If the volume of moist air with 50 % RH is isothermally reduced to half its original volume. then relative humidity of moist air becomes

- A. 25 %
- B. 60 %
- C. 70 %
- D. 100 %

71. In a long cylinder rod of radius R and a surface heat flux of q_0 , the uniform internal heat generation rate is

- A. $\frac{2q_0}{R}$
- B. $2q_0$
- C. $\frac{q_0}{R}$
- D. $\frac{2q_0}{R}$

72. Moist air at 35°C and 100 % relative humidity is entering a psychrometric device and leaving at 25°C and 100 % relative humidity.

The name of the device is

- A. Humidifier
- B. Dehumidifier
- C. Sensible heater
- D. Sensible cooler'

73. A 40 cm diameter disk with emissivity of 0.65 is placed in a large enclosure at 30°C and is effectively a black body. If the disc has a temperature of 55°C, calculate the radiosity of its upper surface

- A. 604 W/m²
- B. 594 W/m²
- C. 560 W/m²
- D. 749 W/m²

74. The vapour compression refrigeration cycle is represented as shown in the figure below, With state ' 1 ' being the exit of the evaporator. The coordinate system used in this figure is

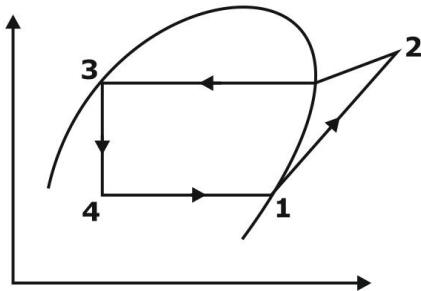

- A. P-h
- B. T-S
- C. p-S
- D. T-h

75. Which of the following configuration has the highest fin effectiveness?

- A. thin, closely spaced fins
- B. thin, widely spaced fins
- C. thick, widely spaced fins
- D. thick, closely spaced fins

76. If the specific humidity of moist air remains same but its dry bulb temperature increases

- A. its dew point temperature increases
- B. its dew point temperature decreases
- C. its dew point temperature remains same
- D. its dew point temperature may increase or decrease depending upon increase or decrease of relative humidity

77. The radiative heat transfer per unit area (W/m^2) between two plane parallel Gray surfaces (emissivity = 0.9) maintained at 400 K and 300K is

- A. 992
- B. 812
- C. 464
- D. 567

78. Refrigerant R-717 is,

- A. Air
- B. Ammonia
- C. Carbon dioxide
- D. Freon-12

79. Which one of the following is the effect of suction vapour superheat?

- A. Decreases the refrigeration effect
- B. Decreases the specific volume
- C. Decreases the energy for compression
- D. Increases the refrigeration effect

80. The room sensible heat loss is 30000 kJ/hr^2 and the latent heat loss is 20000 kJ/hr . Then the sensible heat factor is

- A. 0.667
- B. 0.60
- C. 0.30
- D. 3.00

81. During the adiabatic cooling of moist air

- A. dew point temperature constant
- B. specific humidity remains constant
- C. relative humidity remains constant
- D. wet bulb temperature remains constant

82. Environment friendly refrigerant R 134a is used in the new generation domestic refrigerators. Its chemical formula is.

- A. CHClF_2
- B. $\text{C}_2\text{Cl}_3\text{F}_3$
- C. $\text{C}_2\text{Cl}_2\text{F}_4$
- D. $\text{C}_2\text{H}_2\text{F}_4$

83. The ratio of partial pressure of water vapour (p_v) to the saturation pressure of water vapour (p_s) at same temperature is

- A. relative humidity
- B. degree of saturation
- C. specific humidity
- D. absolute humidity

84. A refrigerator working on a reversed Carnot cycle has a COP of 4 . If it works as a heat pump and consumes 1 kW, the heating effect will be

- A. 1 kW
- B. 4 kW
- C. 5 kW
- D. 6 kW

85. An engine operating on Otto cycle has clearance volume as 10 % of the swept volume. If $\gamma = 1.4$ the air standard cycle efficiency is,

- A. 38.3 %
- B. 39.8 %
- C. 60.2 %
- D. 61,7 %

86. The primary factors responsible for human comfort are
- A. dry bulb temperature, relative humidity and air motion
 - B. dry bulb temperature, dew point temperature and air motion
 - C. dry bulb temperature, relative humidity and latitude of the place
 - D. dry bulb temperature, relative humidity, air motion and elevation of the place

87. Knocking tendency in a SI engine reduces with increasing,
- A. engine speed
 - B. compression ratio
 - C. wall temperature
 - D. supercharging

88. Choose undesirable properties of a secondary refrigerants.
- A. low freezing point
 - B. high viscosity
 - C. good stability
 - D. low vapour pressure

89. Chances of occurrence of cavitation are high if the
- A. local pressure becomes very high
 - B. local temperature becomes low
 - C. thoma cavitation parameter exceeds a certain limit
 - D. local pressure falls below the vapour pressure

90. Partial pressure of water vapour at dew point temperature of moist air is 1.5×10^{-3} MPa. The barometric pressure is 0.1 MPa. The specific humidity of air is
- A. 15.225 gm/kg da
 - B. 9.47 gm/kg da
 - C. 15.00 gm/kg da
 - D. 9.33 gm/kg da

91. If methane undergoes combustion with the stoichiometric quantity of air, the fuel-air ratio non molar basis would be

- A. 15.22: 1
- B. 12.30: 1
- C. 14.56: 1
- D. 9.52: 1

92. For an air-conditioned space, RTH = 100 kW. RSHF = 0.75, volume flow rate of air is 100 m³ minute and room specific humidity is 0.01 kg/kg of dry air. The specific humidity of supply air in kg/kg of dry air is

- A. 0.0100
- B. 0.0075
- C. 0.0050
- D. 0.0025

93. In a Rankine cycle, with the maximum steam temperature being fixed from metallurgical considerations, as the boiler pressure increases

- A. the condenser load will increase
- B. the quality of turbine exhaust will decrease
- C. the quality of turbine exhaust will increase,
- D. the quality of turbine exhaust will remain unchanged

94. If air at dry bulb temperature of 35°C and dew point temperature of 20°C passes through air washer in which water is sprayed at 25°C, then the process would be

- A. sensible cooling
- B. cooling and dehumidification
- C. cooling and humidification
- D. cooling at constant dew point temperature

95. The work ratio in a gas turbine plant is equal to where

r_p = pressure ratio

T_1 = compressor inlet temperature

T_3 = turbine inlet temperature

A. $1 - r_p^{\frac{\gamma-1}{\gamma}}$

B. $1 - \frac{T_1}{T_3} r_p^{\frac{\gamma-1}{\gamma}}$

C. $1 + \frac{T_1}{T_2} r_p^{\frac{\gamma-1}{\gamma}}$

D. $1 + r_p^{\frac{\gamma-1}{\gamma}}$

96. The velocity distribution in the boundary layer is given by $\frac{u}{U} = \frac{y}{\delta}$, where u is the velocity at a distance y from the plate and $u = U$ at $y = \delta$, δ being boundary layer thickness. The displacement thickness is given by

A. δ

B. $\frac{\delta}{2}$

C. $\frac{\delta}{3}$

D. $\frac{2\delta}{3}$

97. A four stroke engine having a brake power of 105 kW is supplied with a fuel at a rate of 4,4 per 10 minutes. The brake specific fuel consumption of the engine is

A. 0.18 kg/kW-hr

B. 0.25 kg/kW-hr

C. 0.36 kg/kW-hr

D. 0.42 kg/kW-hr

98. A circular plate of diameter 1.6 m is placed vertically in water in such a way that the centre of the plate is 2.5 m below the free surface of the water. The location of the centre pressure is

A. 2.564 m

B. 2.5 m

C. 2.864 m

D. 2.654 m

99. Which of the following are effects of nozzle friction?

1. Enthalpy drop decreases

2. Exit velocity reduces

3. Decrease in specific volume

4. Decrease in mass flow rate

Select correct code.

A. (1),(2) and (3)

B. (2), (3) and (4)

C. (1),(3) and (4)

D. (1),(2) and (4)

100 For a heat engine operating on a Carnot cycle, the work output is $1/4^{\text{th}}$ of the heat rejected to the sink. The thermal efficiency of the engine would be

A. 10 %

B. 20 %

C. 30 %

D. 50 %

101. The quality of vapour at the exit of nozzle due to nozzle friction

A. increases

B. decreases

C. does not change

A. unpredictable

102. An ideal gas of mass m and temperature T_1 undergoes a reversible isothermal process from an initial pressure P_1 to final pressure P_2 . The heat loss during the process is Q . The entropy change ΔS of the gas is

A. $mR \ln \left(\frac{P_2}{P_1} \right)$

B. $mR \ln \left(\frac{P_1}{P_2} \right)$

C. $mR \ln \left(\frac{P_2}{P_1} \right) - \frac{Q}{T_1}$

D. zero

103. Which one is NOT a reason behind the fact that the ideal regenerative cycle is practically not possible?

- A. The reversible heat transfer takes infinite, time
- B. It is mechanically impossible to exchange heat in the turbine
- C. The moisture content in the turbine will be high
- D. The steam specific volume will be too high

104. What will be the loss of available energy associated with the transfer of 1000 kJ of heat from constant temperature system at 600 K to another system at temperature 400 K, when, the environment is 300 K ?

- A. 150 kJ
- B. 250 kJ
- C. 500 kJ
- D. 700 kJ

105. An ideal closed cycle gas turbine plant working between temperatures 927°C and 27°C using air as working fluid. The pressure ratio for maximum work output is

- A. 11.3
- B. 13.3
- C. 15.3
- D. 17.3

106. Consider the following properties:

1. Energy
2. Entropy
3. Gibbs
4. Volume
5. Pressure
6. Temperature
7. Viscosity
8. Elasticity

Which of the above are intensive properties ?

- A. 1, 3, 5, 6
- B. 5, 6, 7, 8
- C. 1, 3, 5, 6, 7, 8
- D. 4, 5, 6, 8

107. Air is drawn in a compressor at the rate of 0.8 kg/s at a pressure of 1 bar and temperature of 20°C. Delivering temperature is 90°C and pressure is 10 bar. The air is delivered through an area of $2 \times 10^{-3} \text{m}^2$. If $R = 287 \text{ J/kgK}$, the air exit velocity is

- A. 41.7 m/s
- B. 35.8 m/s
- C. 29.7 m/s
- D. 27.3 m/s

108. For a given value of T_H (source temperature) for a reversed Carnot cycle, the variation of T_L (sink temperature) for different values of COP is represented by which one of the following graphs ?

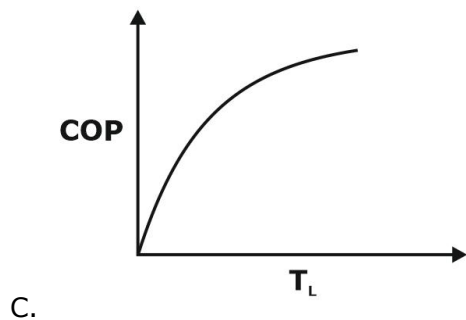
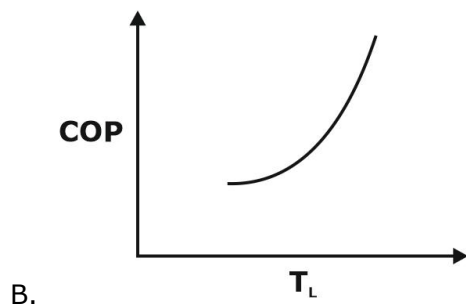
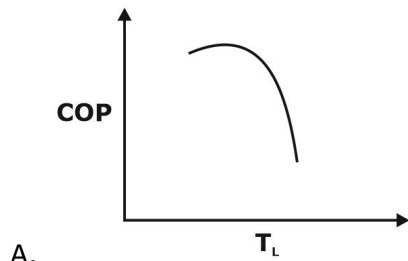

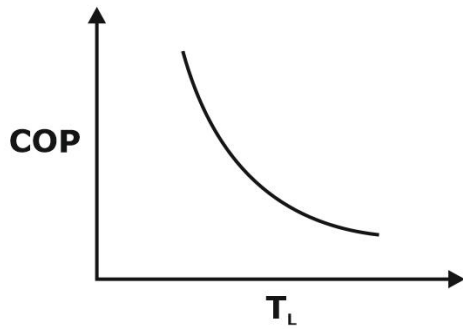

D.

109. Mach angle α and Mach number M are related as

A. $M = \sin^{-1}\left(\frac{1}{\alpha}\right)$

B. $\alpha = \cos^{-1}\left(\sqrt{\frac{M^2 - 1}{M^2}}\right)$

C. $\tan \alpha = (\sqrt{M^2 - 1})$

D. $\alpha = \operatorname{cosec}^{-1}\left(\frac{1}{M}\right)$

110. In the polytropic process, equation $PV^n = \text{constant}$, if n is infinitely large, the process is termed as

A. Constant pressure process

B. Constant volume process

C. Adiabatic process

D. Isothermal process

111. Biogas is predominantly

A. Hydrogen

B. Carbon monoxide

C. Carbon dioxide

D. Methane

112. Change in enthalpy in a closed system is equal to heat transferred if the reversible process takes place at constant

A. temperature

B. internal energy

- C. pressure
- D. entropy

113. In a Rankine cycle, regeneration results in higher efficiency because

- A. pressure inside the boiler increases.
- B. heat is added before steam enters the low pressure turbine
- C. average temperature of heat addition in the boiler increases
- D. total work delivered by the turbine increases.

114. The value of compressibility factor, Z at the critical state of a Van der Waal's gas is

- A. 3.735
- B. 0.735
- C. 3.375
- D. 0.375

115. A diesel engine is usually more efficient than a spark ignition engine because

- A. diesel being a heavier hydrocarbon, releases more heat per kg than gasoline
- B. the air standard efficiency of diesel cycle is higher than the Otto cycle, at a fixed compression ratio
- C. the compression ratio of a diesel engine is higher than that of an spark ignition engine
- D. Self ignition temperature of diesel is higher than that of gasoline

116. A perfect gas having $P_1 = 0.1 \text{ N/mm}^2$, $V_1 = 0.18 \text{ m}^3$, $T_1 = 20^\circ\text{C}$ is compressed to $\frac{1}{10}$ of its volume in an isothermal process. The change in entropy is

- A. -141.45 J/K
- B. 141.45 J/K
- C. -4144.23 J/K
- D. Zero

117 If η_1 and η_2 are the thermal efficiencies of two individual power plants. When they are coupled in series, the overall thermal efficiency η_0 of the combined plant is given by

- A. $\eta_0 = \eta_1 \eta_2$
- B. $\eta_0 = \eta_1 + \eta_2$

C. $\eta_0 = \eta_1 + \eta_2 - \eta_1 \eta_2$

D. $\eta_0 = \frac{\eta_1 + \eta_2}{\eta_1 \eta_2}$

118. A substance whose Joule-Thomson coefficient is negative, is throttled to a lower pressure. During this process.

- A. the entropy of the substance will decrease
- B. the entropy of the substance will remain, constant
- C. the temperature of the substance will decrease
- D. the temperature of the substance will increase

119. Decrease of air-fuel ratio in spark ignition engines results in

- A. increase of NO_x
- B. a decrease of CO and unburnt hydrocarbon
- C. an increase of CO and unburnt hydrocarbon
- D. none of the above

120. A mass of 5 kg of water at 293 K is turned completely to ice at 273 K. The entropy change in the process is

- A. 13479 kJ/K
- B. -1.4847 kJ/K
- C. -7.6195 kJ/K
- D. 8.3195 kJ/K

121. A centrifugal pump driven by a directly coupled 3 kW motor of 1450 rpm speed, is proposed to be connected to a motor of 2900 rpm speed. The power of the motor should be

- A. 6 kW
- B. 12 kW
- C. 18 kW
- D. 24 kW

122. One reversible heat engine operates between 1000 K and T K and another reversible heat engine operates between T K and 400 K. If both heat engines have same heat input and output, the value of T is

- A. 582.7 K
- B. 632.5 K
- C. 682.8 K
- D. 732.5 K

123. The pressure at a point is equal in all directions

- A. only when the fluid is inviscid
- B. when the fluid is incompressible
- C. when the fluid is at rest
- D. in a laminar flow

124. In the figure shown below, 'E' is the heat engine with efficiency of 0.4 and 'R' is the refrigerator. if $Q_2 + Q_4 = 3Q_1$, the COP of the refrigerator will be

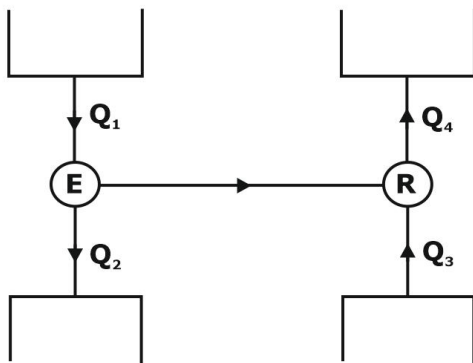

- A. 3.0
- B. 4.5
- C. 5.0
- D. 5.5

125. An automobile moving at a velocity of 40 km/hr is experiencing a wind resistance of 2 kN. If the automobile is moving at a velocity of 50 km/hr, the power required to overcome the wind resistance is

- A. 43.4 kW.
- B. 3.125 kW
- C. 2.5 kW
- D. 27.776 kW