

SECTION A

- Q1.** (a) For a non-inverting amplifier with $A_o = \infty$, calculate the closed loop gain. What happens to the result when $R_1 \rightarrow 0$ and $R_3 \rightarrow 0$? 12

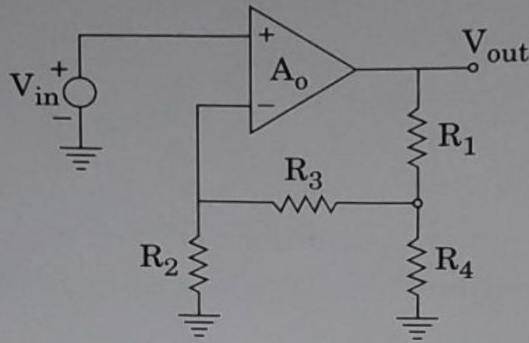

- (b) The accompanying figure depicts the locus of closed loop poles of a system for $0 < K < \infty$. From the plot, determine the frequency with which the system is likely to exhibit sustained oscillation. Determine the value of K at which one of the closed loop poles lie at $s = -8$. 12

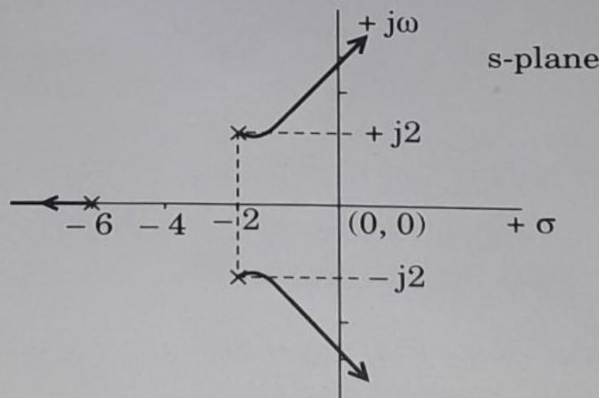

- (c) A 220 V, 8-pole, 4.5 kW, 1100 rpm, lap connected dc generator has 1200 conductors. Each conductor has a resistance of 100 m Ω . The generator is run at half rated speed and is delivering rated current to load. Find the induced emf and corresponding terminal voltage under this condition. Assume constant field flux and no magnetic saturation of the machine during operation. 12

- (d) For a system shown in the figure, a three phase fault occurs at point P which is followed by simultaneous opening of the circuit breakers R_1 and R_2 .

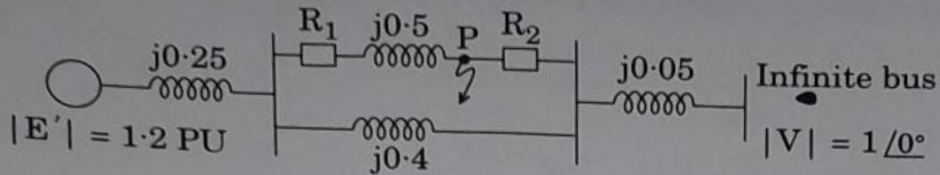

If the generator was delivering 1.0 PU power prior to fault, find the power angle δ in pre-fault condition and the maximum permissible angle δ_{max} post-fault after clearing by removing the faulted line by breakers. 12

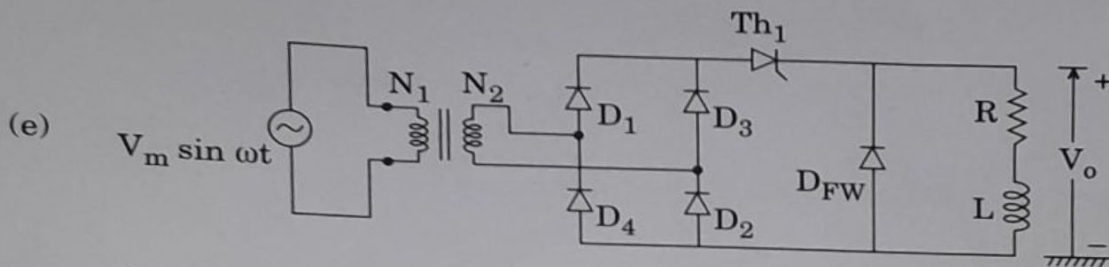

For the circuit shown in the figure,

- Draw the output voltage $V_{o(+)}$ waveform.
- Obtain the expression of $V_{o, av}$, i.e., average output voltage.
- Discuss limitations and application area.

12

Assume thyristors are fired at α with $2f_s$ frequency, where $f_s = \omega/2\pi$ and ω is the synchronous supply frequency.

- Q2. (a) (i) Analytically prove that the following Op-Amp circuit does the function of differential integrator :

8

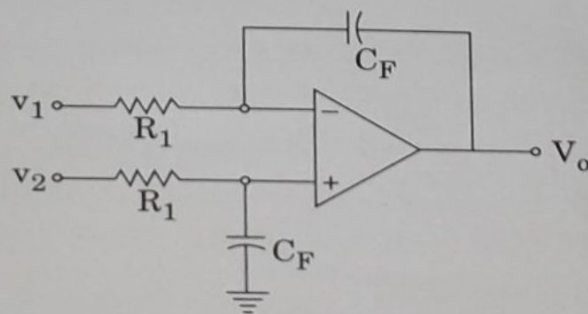

- (ii) A. What is the full scale output of a R – 2R ladder for 4-bit numbers with $R_F = 3R$ and state 0 → 0 V state 1 → 5 V ?
- B. What is the output of above converter with input : 1 0 0 1 ?
- C. An analog signal sensed by a sensor needs to be digitized. The range of analog signal is 0 – 2 V, it is desired that variation of 0.01 V be detected. Assuming maximum frequency content in analog signal is not more than 2 kHz samples, calculate conversion time and resolution required. 12

- (b) (i) For the signal flow graph shown in the figure, determine overall transfer function $M(s) = \frac{C(s)}{R(s)}$. 12

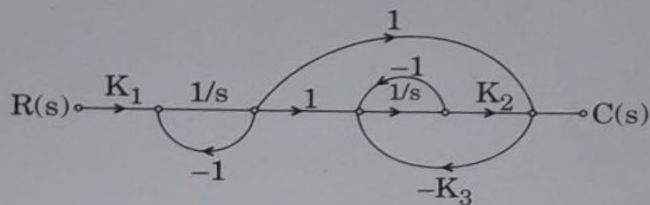

- (ii) For a system represented in the figure, response to a unit step with $K = 1$ is given. For what value of K does the steady state error become zero ? 8

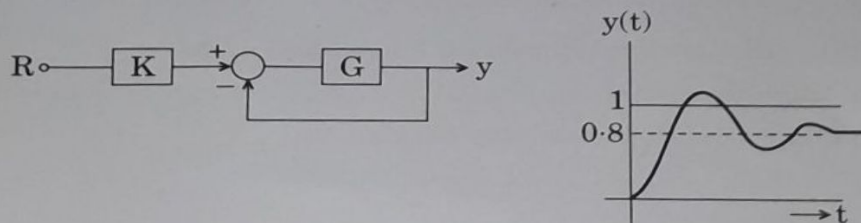

- (c) A three-phase, 6-pole, 50 Hz salient pole alternator is directly connected to 3500 V, 3-phase supply mains to deliver power. It has $X_d = 8.0 \Omega$, $X_q = 6.0 \Omega$ on per phase basis. The excitation is so adjusted to achieve an equivalent per phase internal generated voltage of 1500 V at a load angle of 15 degrees. Find the delivered power, armature current and power factor under this condition.

Now the alternator is made to deliver maximum power under the same value of excitation voltage. Find the new value of load angle and delivered power under this situation. 20

- Q3. (a) An induction motor of 1.5 kW, 3-phase, 415 V, 50 Hz, 1440 rpm is to undergo blocked rotor and no load tests. The motor is located away from the supply panel and the per phase impedance of the connecting cable is $(5 + j 2.5) \Omega$. The metering is done at the panel end. The motor draws 0.7 A current and takes 150 W input power under no load condition at rated voltage. For blocked rotor condition, it draws a current of 2.5 A and takes input power of 250 W when 75 V (L - L) is applied from the panel. Calculate the machine equivalent circuit parameter referred to stator side.

20

(Assume equal distribution of resistance and leakage reactance between rotor and stator, negligible rotation losses and star connected stator of the machine.)

- (b) A three-phase, 50 Hz transmission line has a span of 250 km. It supplies a balanced load of 25 MVA at 0.8 lagging power factor. The receiving end load voltage is 132 kV. The line conductors are spaced equilaterally 3 m apart. The conductor resistance is 0.11 ohm/km and its effective diameter is 1.6 cm. Using the nominal-T method, find sending end voltage and current. Also determine the voltage regulation at receiving end of transmission line.

20

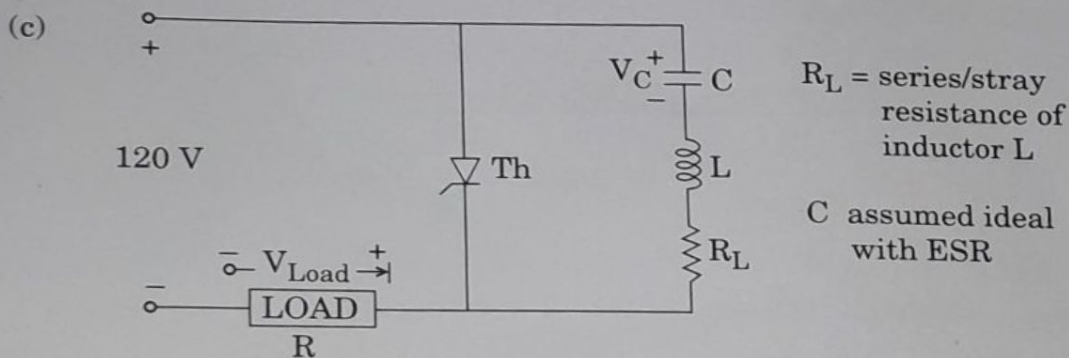

The circuit shown in the figure is in steady state with thyristor OFF for a long time. Find the suitable values of L and C for the circuit so that current pulse across the load $R = 550 \Omega$ is approximately of 1 ms. The circuit is designed to generate a pulse of $0.75 T$, where T is period of resonant circuit. It is assumed that subsequent firing of thyristor occurs after 1 ms and inductor is ideal, i.e., $R_L = 0$. Derive all expressions with $R_L \neq 0$.

Also, plot the time variation of $V_{C(+)}$ and $V_{Load(+)}$ for one cycle.

20

- Q4. (a) Let $x(t)$ be the rectangular pulse as shown in Figure (1). Express the signal $y(t)$ shown in Figure (2) in terms of rectangular pulse $x(t)$. 20

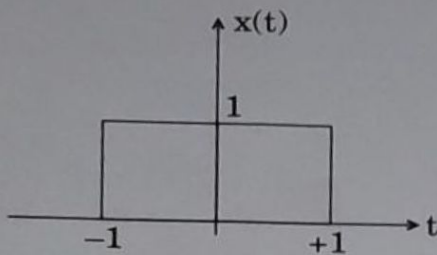

Figure (1)

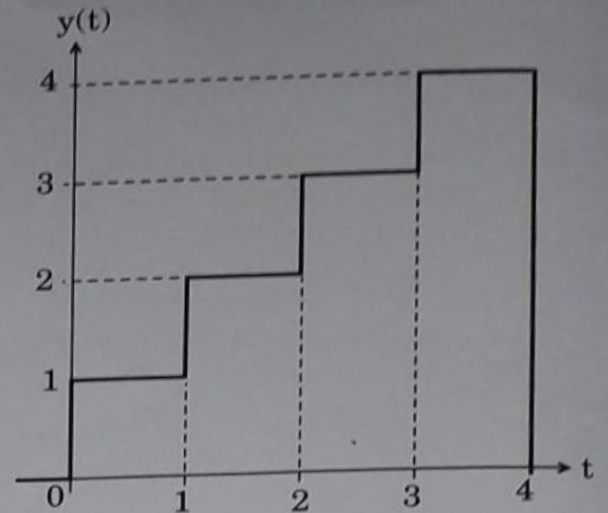
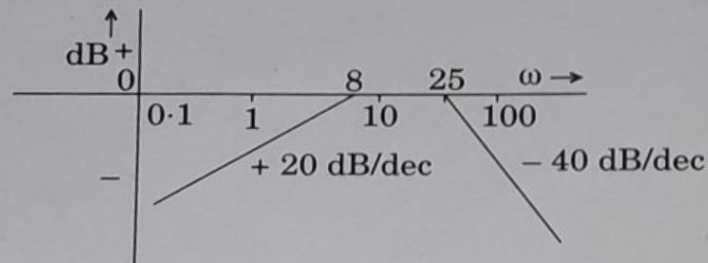

Figure (2)

- (b) (i) From the Bode asymptotic magnitude plot of a minimum phase system, determine the open loop transfer function. What is the gain margin of resulting unity negative feedback closed loop system? 10



- (ii) Given the open loop transfer function

$$G(s)H(s) = \frac{K}{(s+4)(s-8)}$$

Using Nyquist stability criteria, determine the condition for closed loop stability. Verify the result using Routh-Hurwitz test. 10

- (c) A single phase ac controller supplied from a source, $V_{in} = 220 \sin 314.28 t$ produces an rms output voltage of 110 V for a resistive load of 10Ω at a firing angle α . Determine

- (i) the value of α , 4
 (ii) the amplitude of the seventh harmonic current for $\alpha = \pi/6$, and 8
 (iii) the input power factor. 8

SECTION B

- Q5. (a) Consider the FIR filter described by the equation

$$y(n) = x(n) + x(n - 4).$$

Determine its response to the input

$$x(n) = \cos\left(\frac{\pi}{2}n\right) + \cos\left(\frac{\pi}{4}n\right), \quad -\infty < n < \infty.$$

Comment on the results obtained.

12

- (b) Forward path transfer function of a unity negative feedback system is $G(s) = \frac{25}{s(s+20)^2}$. Without drawing graph, analytically determine the gain margin.

12

- (c) A transformer of 150 kVA with 1% resistance and 4% leakage reactance is operating in parallel with another 300 kVA transformer having 1% resistance and 6% leakage reactance. The combination is delivering a load of 450 kVA at 400 V and unity power factor. Find the kVA loading on the 150 kVA transformer and the additional reactance to be connected in series with it to provide rated kVA loading on this transformer.

12

- (d) (i) A single phase overhead transmission line of 50 km length is to be designed with copper conductor of 5.04 cm diameter. It is expected to have a maximum line reactance of 31.4 Ω . Determine the optimal spacing between the conductors.

6

- (ii) Discuss the impact on line reactance if the conductors in the above case are replaced by stranded bundle conductors of the same outer diameter and line spacing. Assume an ACSR conductor with 6 conductors of Aluminium of 1.68 cm diameter each around one central steel conductor for your analysis.

6

- (e) A buck converter is operating from a 24 V dc input voltage with variation of $\pm 10\%$. The required output voltage is 9 V dc with allowable voltage ripple of 100 mV. The converter has rated capacity of 20 W and is operating at a switching frequency of 40 kHz. Find the minimum values of inductance and capacitance to be provided in the output filter for (i) keeping the inductor current peak to peak ripple at 0.5 A, and (ii) inductor current to be just continuous.

12

(Assume the converter is operating at rated power)

- Q6.** (a) Consider the function $Y(A, B, C)$ given in the truth table.

A	B	C	Y(A, B, C)
0	0	0	1
0	0	1	0
0	1	0	0
0	1	1	0
1	0	0	1
1	0	1	1
1	1	0	0
1	1	1	1

- (i) Write a logic expression for $Y(A, B, C)$.
- (ii) Implement $Y(A, B, C)$ using only 2-input gates.
- (iii) Implement $Y(A, B, C)$ using only 2-input NAND gates. 20
- (b) (i) Find the resolution and the bit rate in the sampling of a signal with dynamic range of 1 volt if the sampling rate is $F_s = 20$ samples/sec and an 8-bit A/D converter is used. Determine the maximum frequency that can be present in resulting digital signal. 6

- (ii) In a signal processing system shown below, sampling periods of the Analog to Digital and Digital to Analog converters are $T = 5$ m sec and $T' = 1$ m sec respectively. Find the output $y_a(t)$ of the system if the input is

$$x_a(t) = 3 \cos(100\pi t) + 2 \sin(250\pi t).$$

14

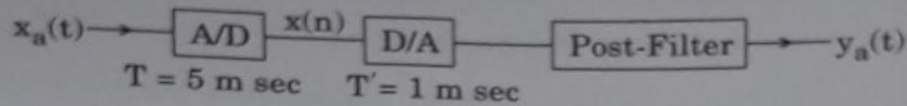

(Post-filter removes frequency components that are above $\frac{F_s}{2}$.)

- (c) The signal flow graph of a system relating output $y(t)$ to input $u(t)$ is shown in the figure. Represent the state variable model of the system. Determine its transfer function $\frac{y(s)}{u(s)}$ from the state model.

Derive corresponding state transition matrix.

20

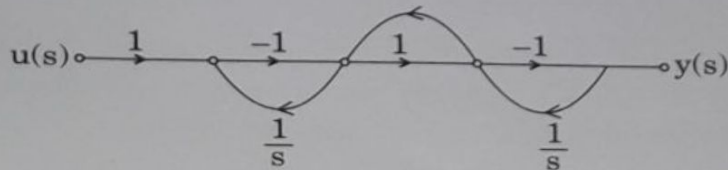

- Q7. (a) (i) The frequency response of a steady state gain already adjusted open loop transfer function is shown in the figure. Appropriately using the parameters highlighted in the figure, design a Lag compensator to achieve a desired phase margin of $+30^\circ$ with a tolerance considered as 8° . Illustrate the design procedure clearly. 12

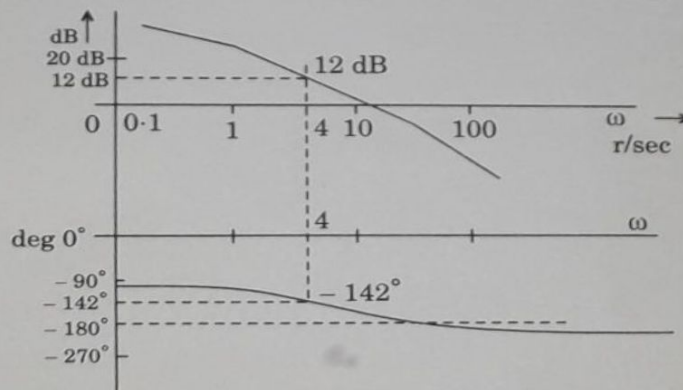

- (ii) Consider a system described by the state model

$$\dot{X} = \begin{bmatrix} -3 & 1 \\ -2 & 0 \end{bmatrix} X + \begin{bmatrix} 0 \\ 1 \end{bmatrix} u;$$

$$y = [1 \quad 0] X.$$

Design a control law $u = -KX$ so that the closed loop poles of the system occupy in s-plane at $-2 \pm j2$.

8

- (b) A 415 V, 4-pole, 3-phase, 50 Hz, 1440 rpm induction motor has per phase standstill rotor resistance and reactances of 0.4Ω and 1.3Ω respectively at rated frequency. Find torque at rated speed and the ratios of starting torque to maximum torque and rated torque to maximum torque.

Now, the motor is supplied from a source of 40 Hz at 20% reduced voltage. Find the operating slip at rated torque and the new ratios of rated torque to maximum torque and starting torque to maximum torque.

20

(Assume no saturation and negligible stator impedances)

- (c) A 100 MVA, 20 kV, 50 Hz three-phase generator is connected to a 100 MVA 20/400 kV three-phase transformer. The machine has the following per unit reactances and time constants :

$$X_d'' = 0.15 \text{ pu} \quad \tau_d'' = 0.035 \text{ sec}$$

$$X_d' = 0.25 \text{ pu} \quad \tau_d' = 0.5 \text{ sec}$$

$$X_d = 1.25 \text{ pu} \quad \tau_d = 0.3 \text{ sec}$$

The transformer reactance is 0.25 per unit. The generator is operating at the rated voltage and no-load when a three phase short-circuit occurs at the secondary terminals of the transformer.

Find the subtransient, transient and the steady state short circuit currents in per unit and actual amperes on both sides of the transformer.

20

- Q8.** (a) Determine the unilateral Laplace transform of the signals given below. Specify the property used, if any, in each step.

20

(i) $x(t) = u(t - 1) * e^{-2t} u(t - 1)$

(ii) $x(t) = t \cdot \frac{d}{dt} (e^{-t} \cdot \cos(t) u(t))$

- (b) A 10 kVA, 50 Hz single-phase transformer has a maximum efficiency of 97% at rated frequency and rated voltage while delivering 90% of rated load at 0.8 pf lag. The same transformer shows maximum efficiency of 96% at same load when supplied from a 35 Hz source at rated voltage. Find (i) the hysteresis and core losses of the transformer under rated condition and (ii) efficiency of the transformer at rated voltage and rated load at 0.8 pf lag.

20

(Assume no stray losses and a Steinmetz constant of 2.0 for the core)

- (c) A 10 kW, 220 V, 1750 rpm dc separately excited motor is controlled by a three-phase fully controlled converter. The connecting cable between motor and converter has a resistance of 1.0 Ω . The input side of the converter is supplied from a 3-phase 300 V, 50 Hz ac source. The dc motor has armature resistance $r_a = 0.5 \Omega$. The armature current is flat and ripple free. Determine

- (i) the triggering angle of the converter when the motor delivers rated power at rated voltage and speed.
- (ii) the converter input rms current and power factor under the above condition of (i).
- (iii) no load speed of the motor when the triggering angle is same as (i) and the motor takes 10% of rated current.

20

(Assume constant field current at rated value for the entire operation)